

MTX 75 Transmission - Dismantle and Assemble (16 118 8)

(transmission removed)

Special Tools

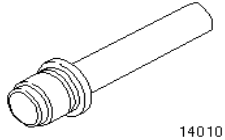

14010

14-010 Installer, bearing cups

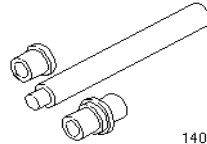

14011

14-011 Installer, selector shaft oil seal

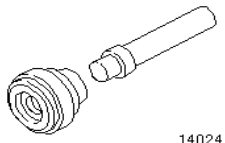

14024

14-024 Installer, bearing rings



15026A01

15-026A01 Thrust pad

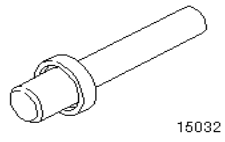

15032

15-032 Installer, differential bearing

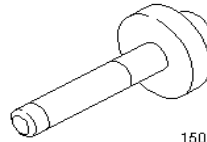

15036

15-036 Installer, bearing rings

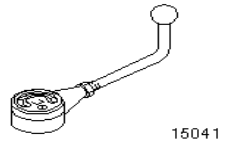

15041

15-041 Preload gauge

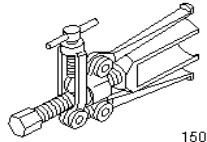

15048

15-048 Remover, bearing rings

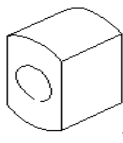

15048-01

15-048-01 Adaptor

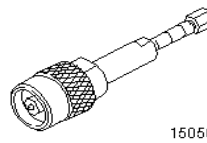

15050A

15-050A Remover, taper roller bearing (basic tool)

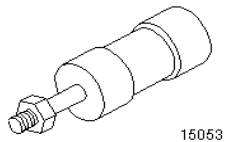

15053

15-053 Slide hammer

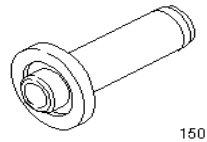

15058

15-058 Installer, differential oil seal



15073

15-073 Socket

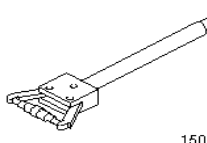

15074

15-074 Remover, bearing rings

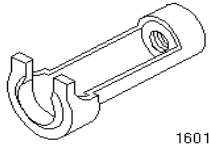

16019

16-019 Remover/installer, selector shaft oil seal

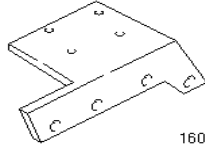

16058

16-058 Mounting plate, transmission

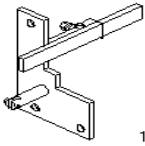

16059

16-059 Measuring fixture, end float output shaft

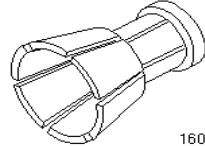

16060

16-060 Collet for 15-050A

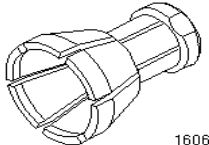

16061

16-061 Collet for 15-050A

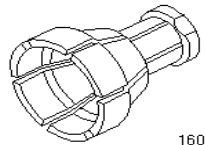

16062

16-062 Collet for 15-050A

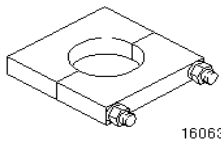

16063

16-063 Pressure plate, gear wheel removal

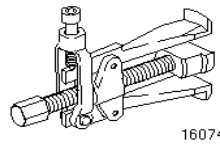

16074

16-074 Remover, driveshaft oil seal

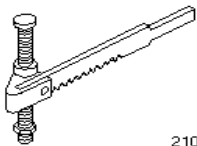

21024

21-024 Valve spring compressor

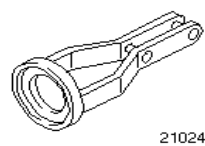

2102402

21-024-02 Adaptor for 21-024

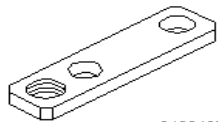

2102407

21-024-07 Adaptor for 21-024

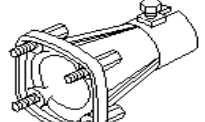

21031B

21-031 B Mounting bracket, transmission

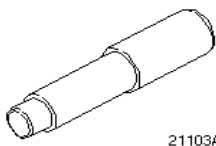

21103A

21-103A Remover/installer, selector shaft ball sleeves

Proprietary Tools

Magnetic fixture
Dial gauge
Hot air fan

Workshop Equipment

Press	
-------	--

Materials

--	--

High-temperature grease	ESD-M1C220-A
Sealer	WSK-M2G348-A5
Transmission fluid (ATF)	WSD-M2C200-C
Freezing spray	

Measuring and Adjusting Shims

	Input Shaft	Output Shaft	Differential
Measuring shim in mm	1,00	1,00	1,10
Adjustment shim availability (mm)	1,15 - 1,71	1,31 - 1,91	1,40 -- 2,20

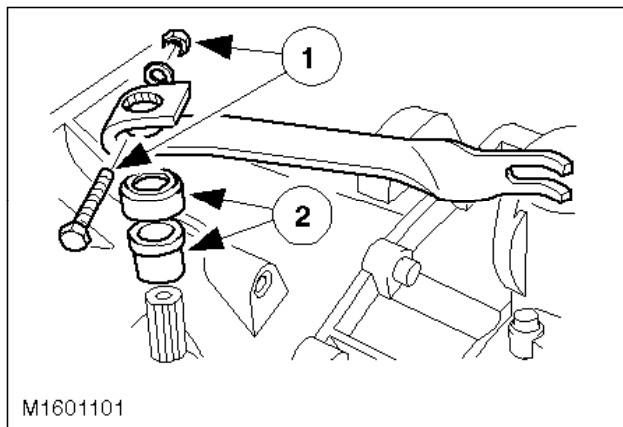

Transmission - Dismantle

- ⦿ 1. Detach the clutch release lever.
 - 1 Undo the bolt and pull off the lever.
 - 2 Withdraw the gaiter and the bearing bush from above.

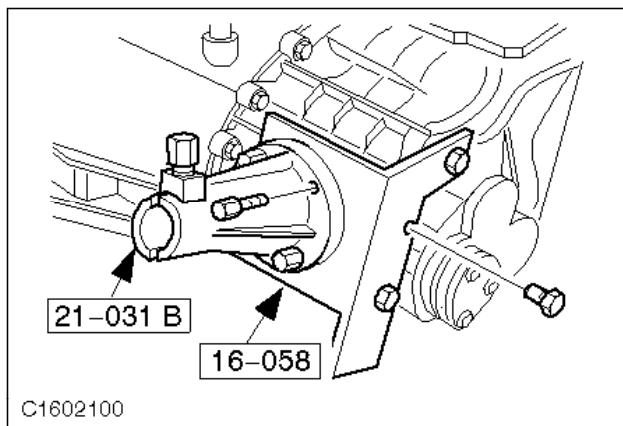

- ⦿ 2. Attach the special tool.

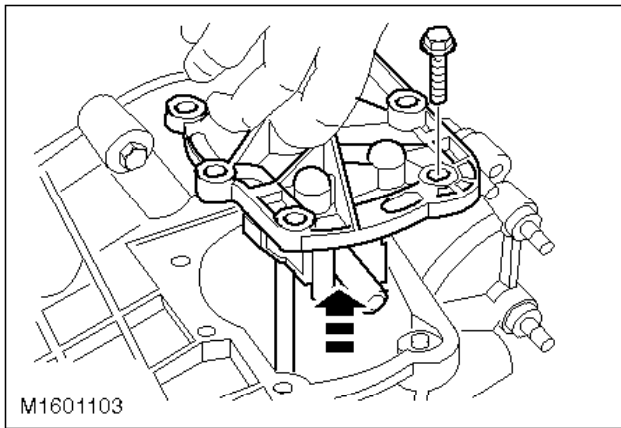

3. Remove the selector mechanism.
- Put the transmission in neutral.
 - Undo the six bolts.
 - Remove the complete selector mechanism assembly.

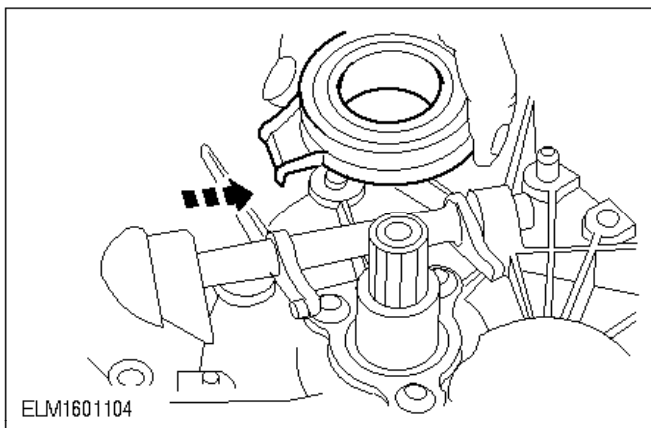

4. Remove the thrust bearing and the release shaft.

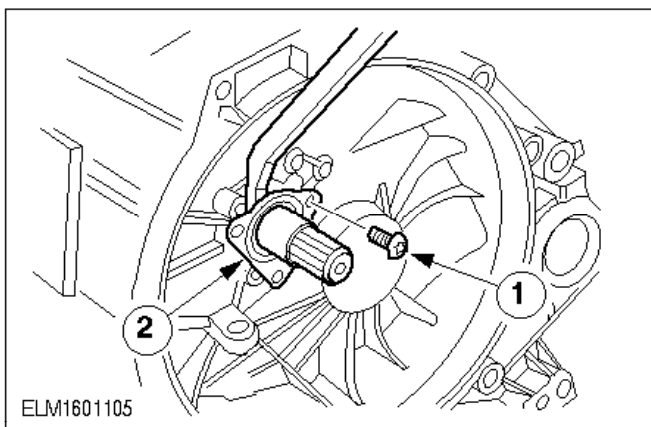

5. Remove the guide sleeve.
- 1 Undo the three bolts.
 - 2 Twist the guide sleeve and prise off.

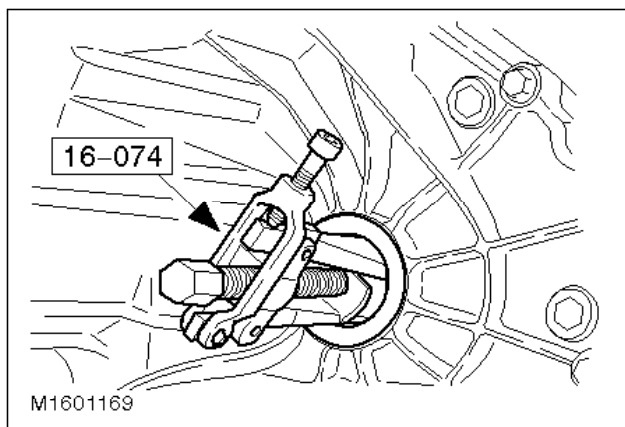

- 6. Remove the driveshaft oil seals with the Special Tool.

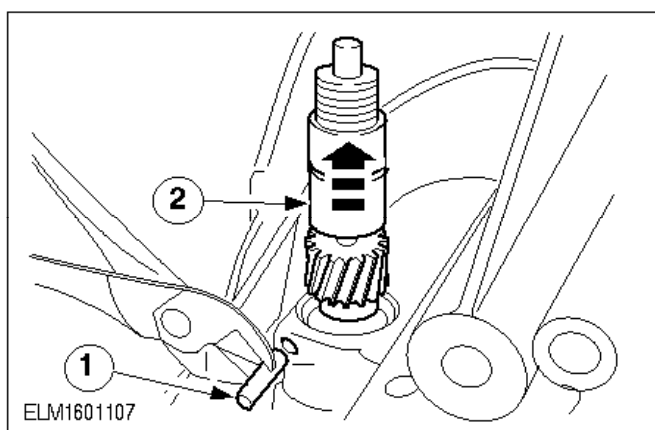

- 7. Detach the speedometer drive pinion.
 - 1 Pull out the roll pin.
 - 2 Pull out of drive pinion.

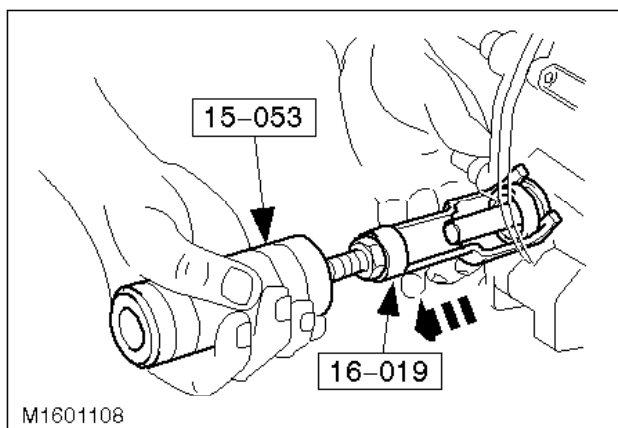

Detach the selector shaft oil seal.

- 8. Pull off the oil seal using the special tool.

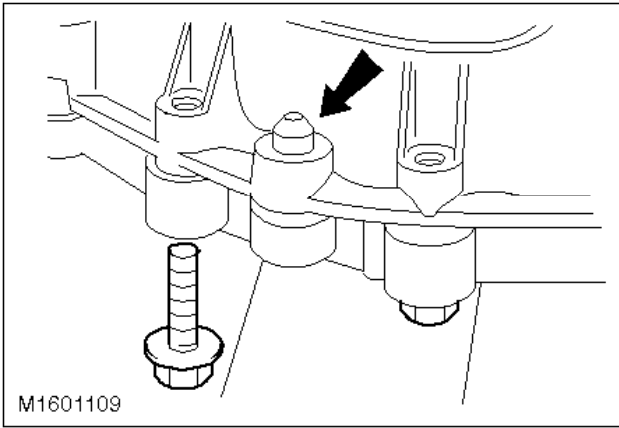

Note:

Do not drive out the dowel pins.

- 9. Remove the transmission housing bolts.

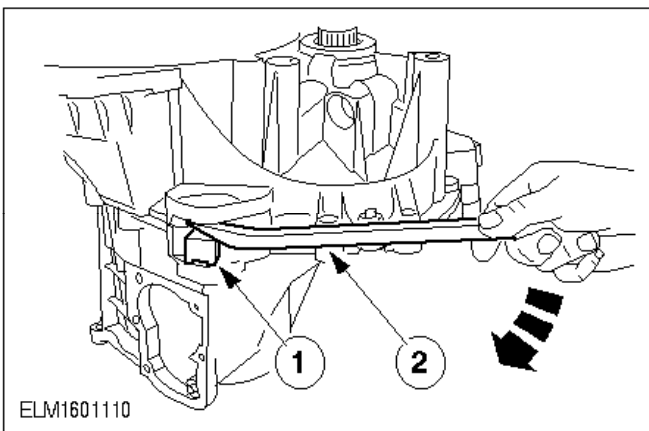

CAUTION:

Do not damage the transmission housing.

- 10. Separate the transmission housing halves
 - 1 Use a support.
 - 2 Separate the housing sections using two levers positioned opposite each other.

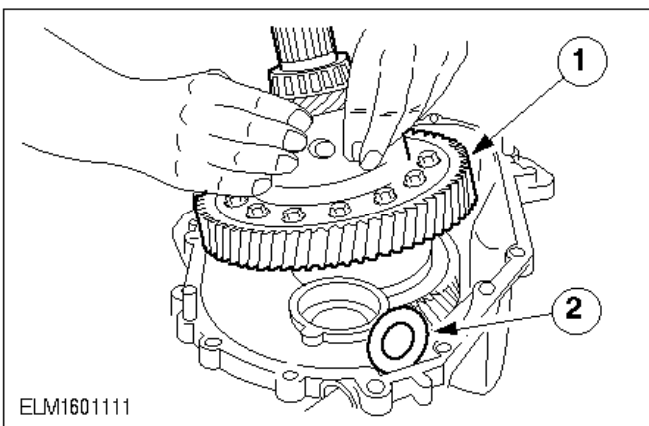

- 11. Remove the differential.
 - 1 Lift out the complete differential assembly.
 - 2 Take out the magnetic disc.

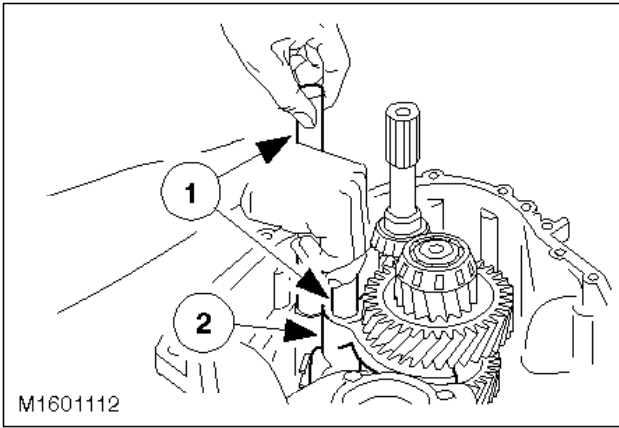

12. Remove the first/second gear selector rods and selector fork.

- 1 Remove the selector rods.
- 2 Remove the first/second gear selector fork.

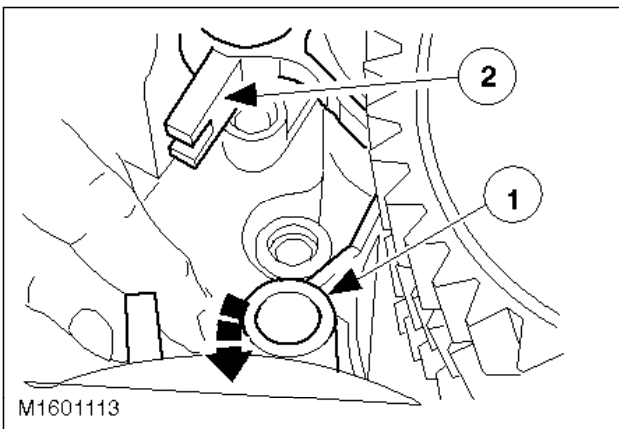

13. Remove the first/second gear selector forks.

- 1 Swivel the fifth/reverse gear selector fork to one side.
- 2 Turn the third/fourth gear selector fork and remove it.
- Remove the fifth/reverse gear selector fork.

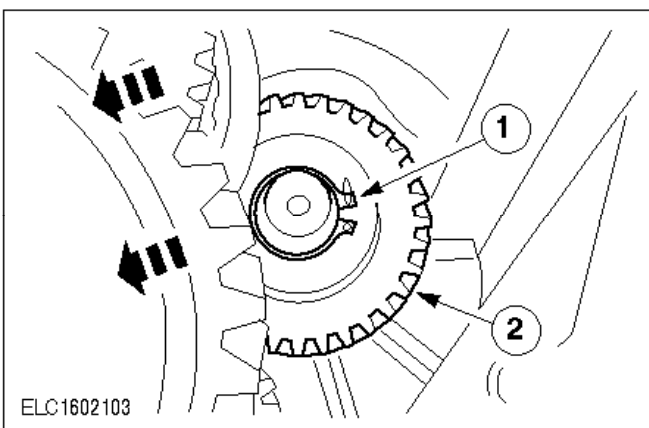

14. Remove the reverse gear idler.

- 1 Detach the circlip.
Tilt the input and output shafts to the side.
- 2 Remove the reverse gear idler by pulling it upwards (see following step for removal sequence).

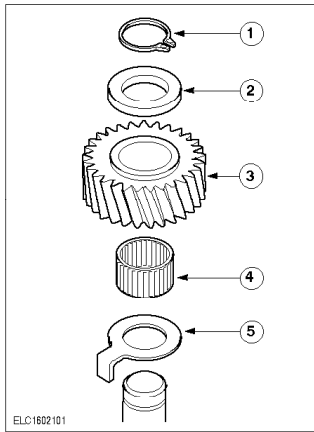

15. Removal sequence for removing the reverse gear idler.

- 1 Circlip
- 2 Upper thrust washer
- 3 Reverse gear idler
- 4 Needle roller bearing
- 5 Lower thrust washer

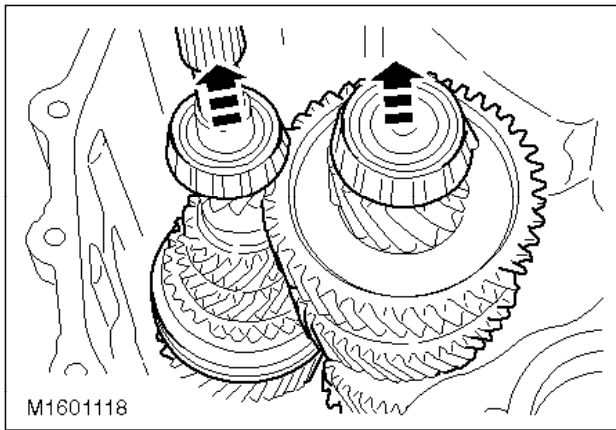

16. Remove the input and output shafts.

- Lift the input and output shafts together out of the transmission housing.
- Take out the mounting block and reverse idler gear together with the needle roller bearing and thrust washers.

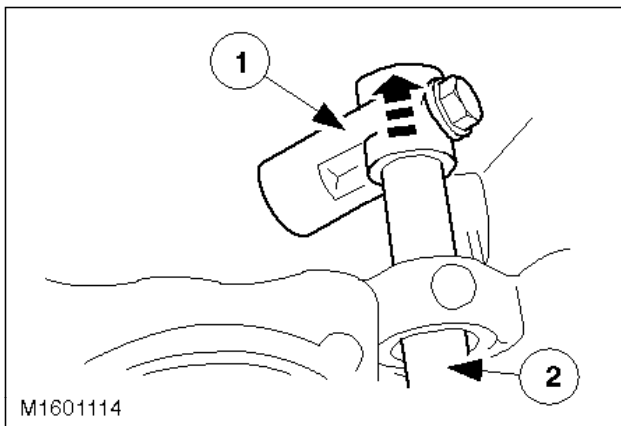

17. Remove the selector shaft.

- 1 Undo the ball socket and take off the selector shaft.
- 2 Pull off the selector shaft.

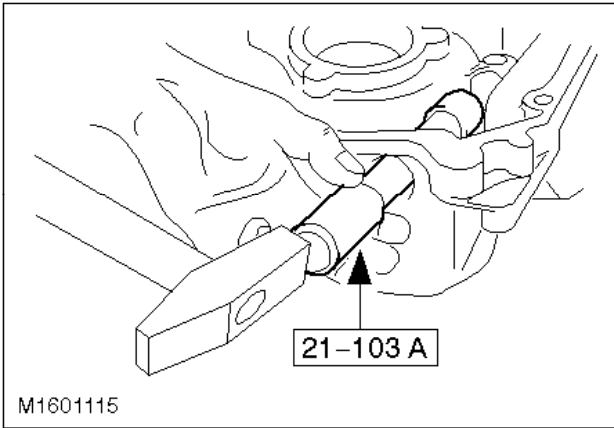

- 18. Remove the selector shaft ball sleeves.

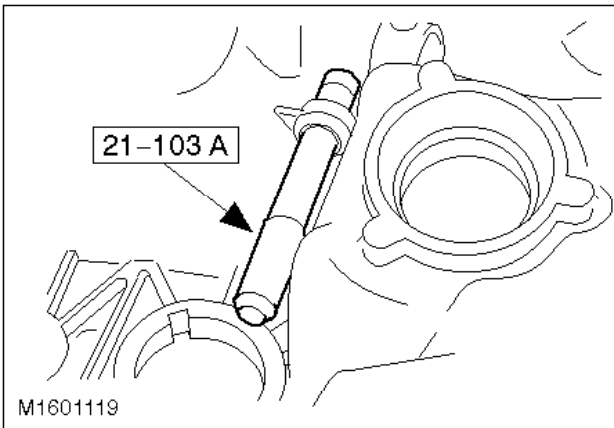

- 19. Remove the inner selector shaft bearing bush.

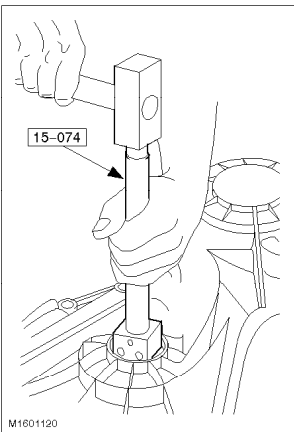

Remove the bearing rings.

Note:

Fit the special tool in the transmission recesses.

- 20. Take off the differential bearing ring.

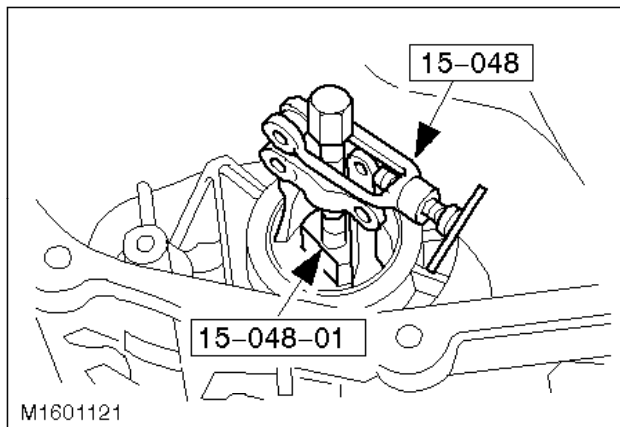

Note:

Fit the special tool in the transmission recesses.

- 21. Remove the bearings rings from the input and output shafts.

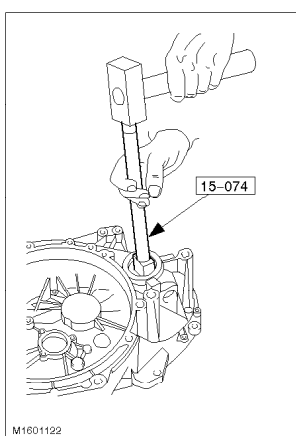

Note:

Fit the special tool in the transmission recesses.

- 22. Remove the differential and the bearing rings.

- From the input shaft
- From the differential

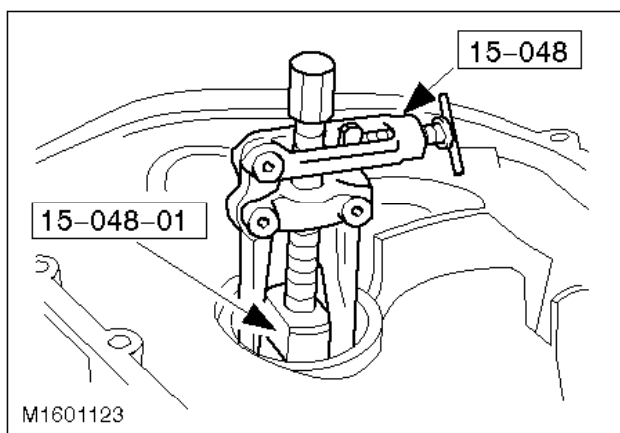

Note:

Fit the special tool in the transmission recesses.

- 23. Remove the input shaft bearing ring and the shim.

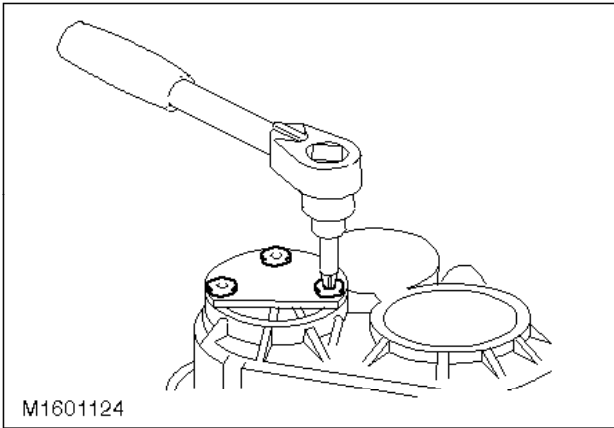

Note:

Only carry out if there is damage or leaks.

- ⦿ 24. Remove the reverse gear idler shaft.

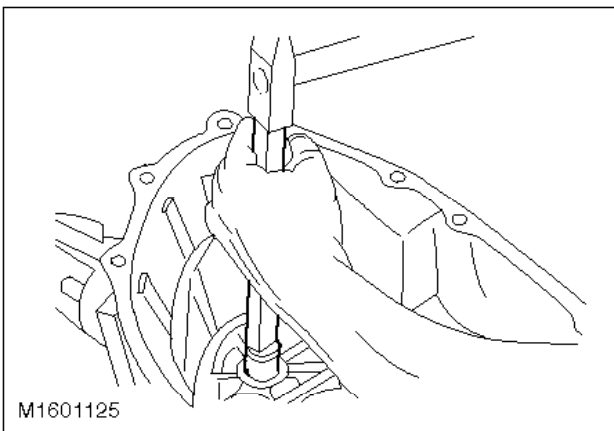

Note:

See previous step.

- ⦿ 25. Drive out the reverse gear idler shaft with a block of hardwood.

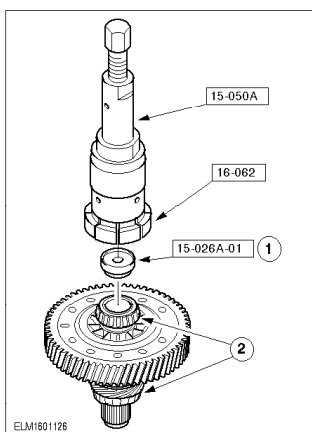

Dismantle the differential.

- ⦿ 26. Pull the taper roller bearing off the differential.

- 1 Insert the thrust pad.
- 2 Pull off the taper roller bearing.
Detach the speedometer worm gear.

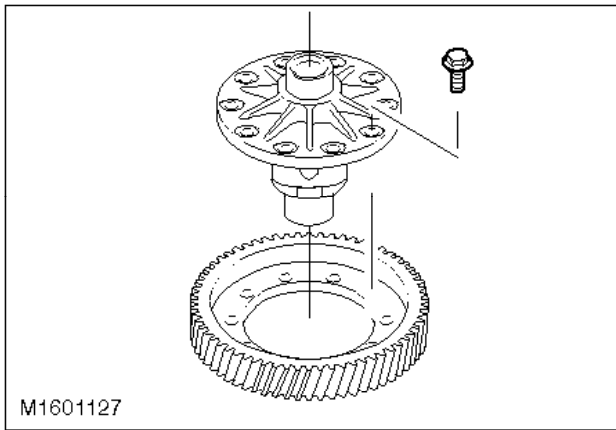

27. Detach the crown wheel.

Note:

Use a copper hammer.

Unscrew the retaining bolts and separate the crown wheel from the differential cage by tapping lightly.

28. General note.

Note:

From model year '95 a double synchroniser is installed for 1st, 2nd and 3rd gears. The layout and assembly of the single synchroniser for 3rd gear is identical to that for 4th gear. The steps described below refer to the double synchroniser. Refer to the Technical Data table for details of replacement synchroniser parts.



CAUTION:

The inner synchroniser ring and the synchroniser cone must be handled with great care.

The layout and assembly of the single synchroniser for 3rd gear is identical to that for 4th gear.

The steps described below refer to the double synchroniser. Refer to the Technical Data table for renewal of synchroniser parts.

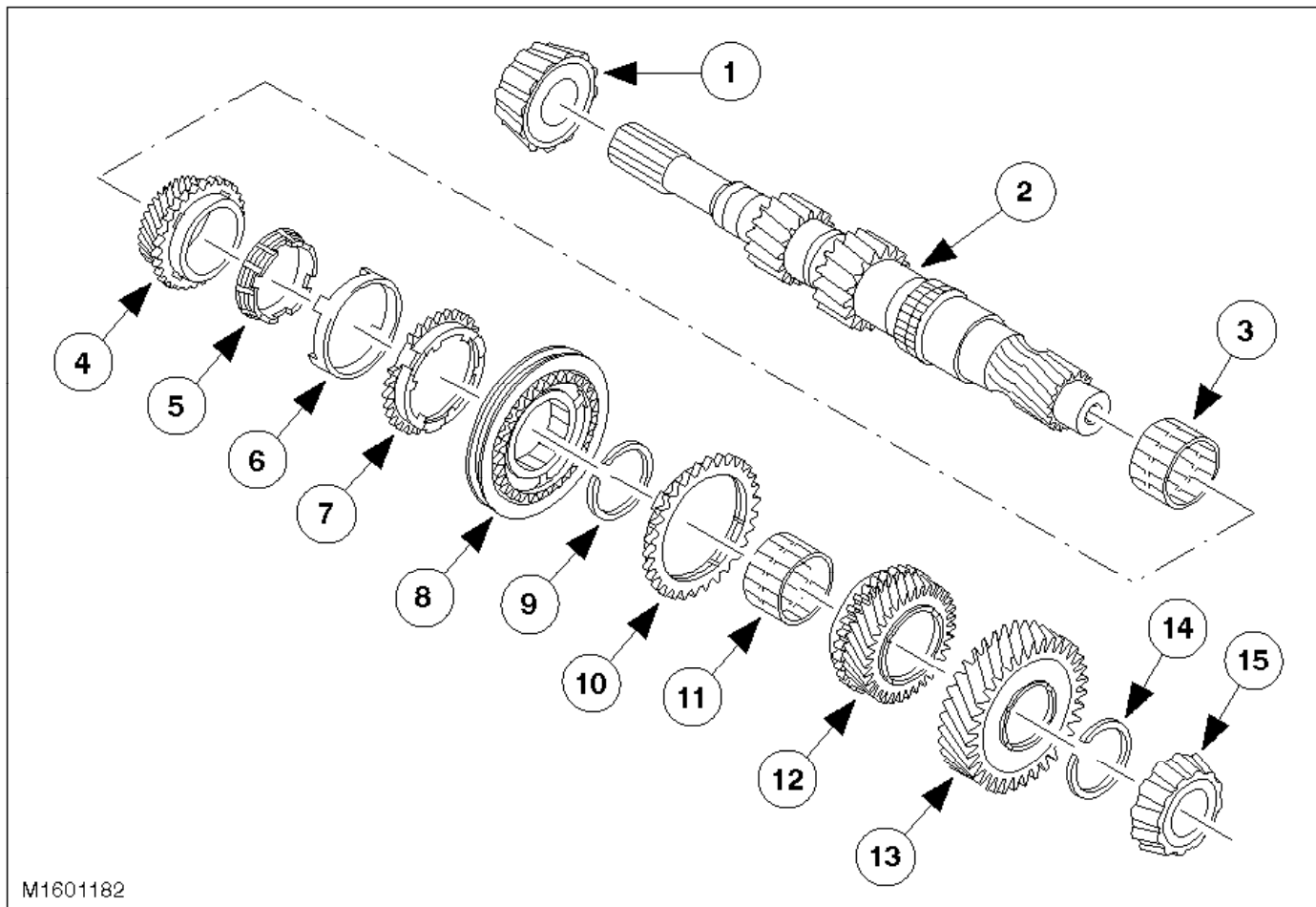

M1601182

Layout of the input shaft

Item	Description
1	Taper roller bearing, clutch end
2	Input shaft
3	Needle roller bearing for 3rd gear wheel
4	3rd gear wheel
5	3rd gear inner synchroniser ring
6	3rd gear synchroniser cone
7	3rd gear outer synchroniser ring
8	3rd/4th gear synchroniser assembly
9	Circlip
10	4th gear synchroniser ring
11	Needle roller bearing for 4th gear
12	4th gear wheel
13	Fifth gear wheel
14	Circlip

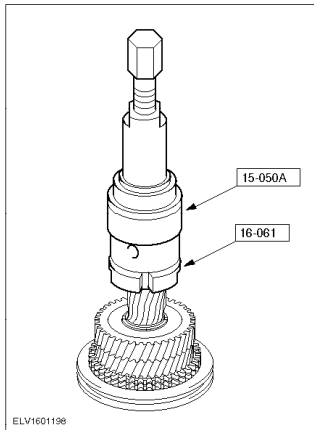

Dismantle input shaft

Note:

Taper roller bearing and fifth gear wheel can also be pressed off together (see following step).

29. Pull off the taper roller bearing on the transmission side.

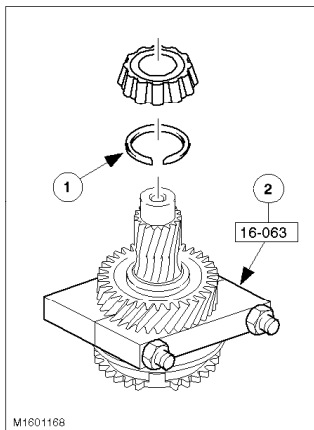

30. Press off the fifth gear wheel together with the taper roller bearing.

- 1 Move the circlip upwards out of the annular groove up to the taper roller bearing.
- 2 Press off the gear wheel together with the circlip and the taper roller bearing.

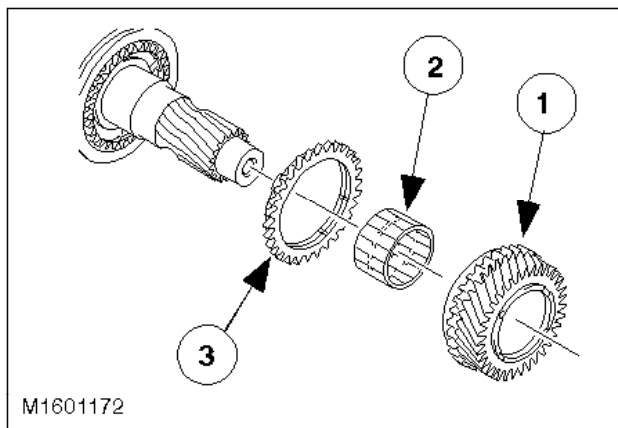

31. Detach the fourth gear wheel together with needle roller bearing and synchroniser ring.

- 1 Gear wheel
- 2 Needle roller bearing
- 3 Synchroniser ring

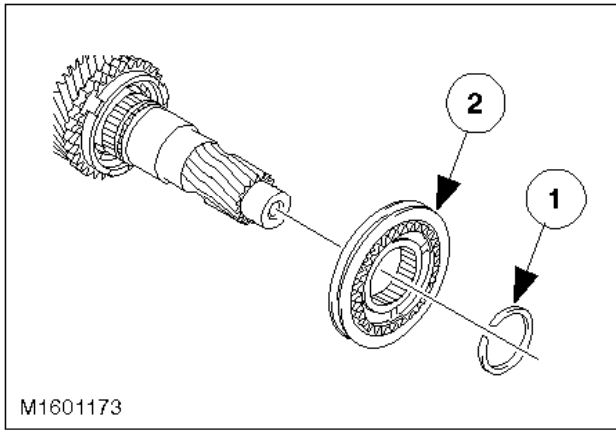

32. Detach the 3rd/4th gear synchroniser assembly.

- 1 Circlip
- 2 Gear synchroniser

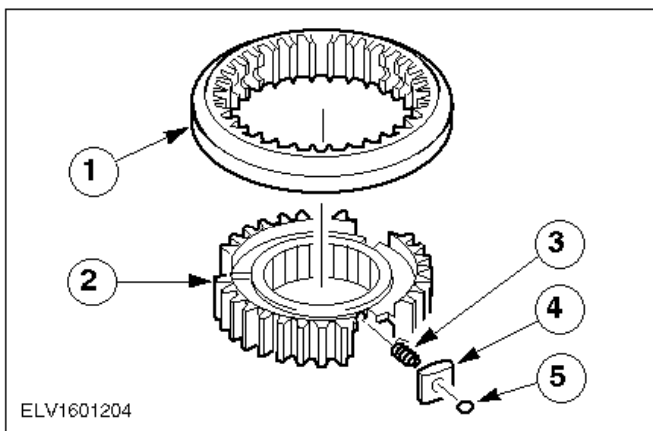

CAUTION:

Carefully pull the selector ring off the gear synchroniser hub; the detent balls are spring-tensioned.

Note:

Mark the installation location of the selector ring.

33. Dismantle the gear synchroniser.

- 1 Selector ring
- 2 Gear synchroniser hub
- 3 Compression spring
- 4 Blocker bar
- 5 Detent ball

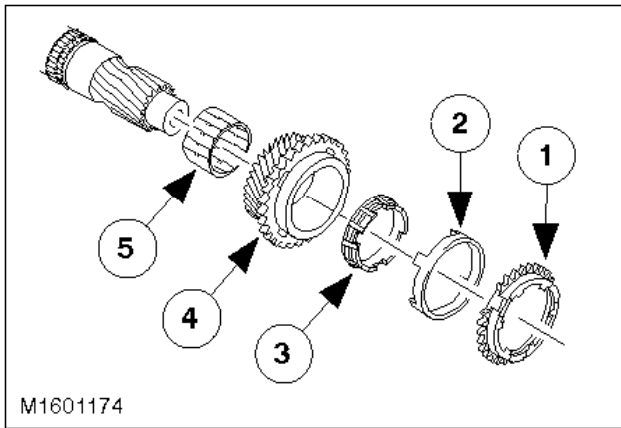

34. Detach third gear wheel together with the double synchroniser.

- 1 Outer synchroniser ring
- 2 Synchroniser cone
- 3 Inner synchroniser ring
- 4 Gear wheel
- 5 Needle roller bearing

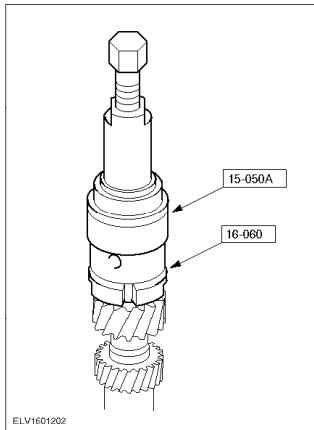

35. Pull the taper roller bearing on the clutch side off the input shaft.

36. General note.

Note:

From model year '95 a double synchroniser is installed for 1st, 2nd and 3rd gears. The layout and assembly of the single synchroniser for 3rd gear is identical to that for 4th gear. The steps described below refer to the double synchroniser. Refer to the Technical Data table for details of replacement synchroniser parts.



CAUTION:

The inner synchroniser ring and the synchroniser cone must be handled with great care.

The layout and assembly of the single synchroniser for 3rd gear is identical to that for 4th gear.

The steps described below refer to the double synchroniser. Refer to the Technical Data table for renewal of synchroniser parts.

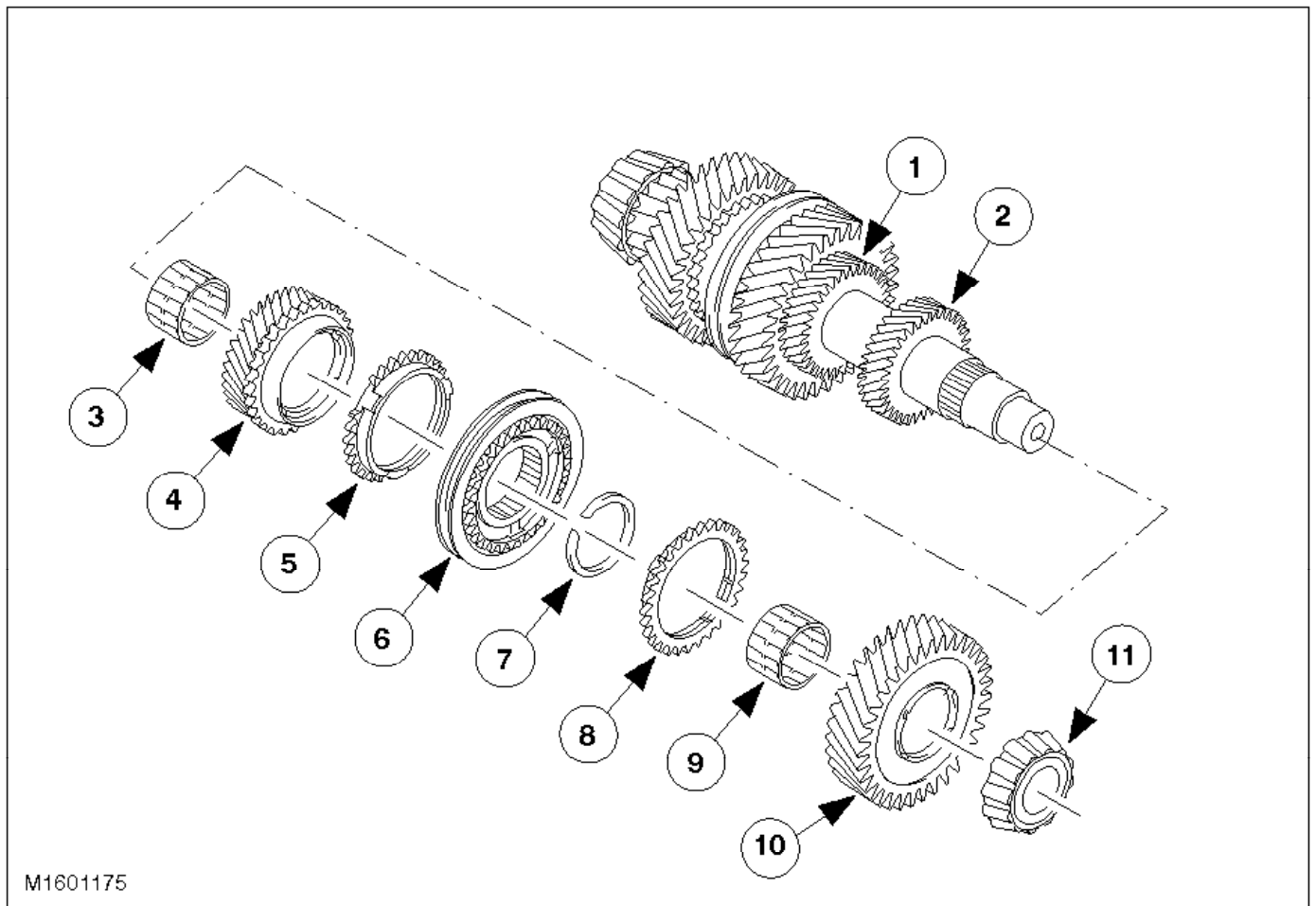

M1601175

Layout of output shaft

Item	Description
1	3rd gear wheel
2	4th gear wheel
3	4th gear needle roller bearing
4	Fifth gear wheel
5	5th gear synchroniser ring
6	Fifth/reverse gear synchroniser, complete
7	Circlip
8	Reverse synchroniser ring
9	Reverse gear needle roller bearing
10	Reverse gearwheel
11	Taper roller bearing on the transmission side.

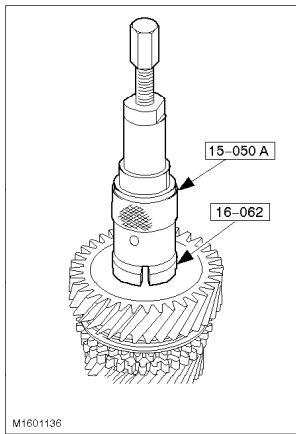

Dismantle output shaft

Note:

Taper roller bearing and reverse gear wheel can also be pressed off together.

- 37. Pull off the taper roller bearing on the transmission side.

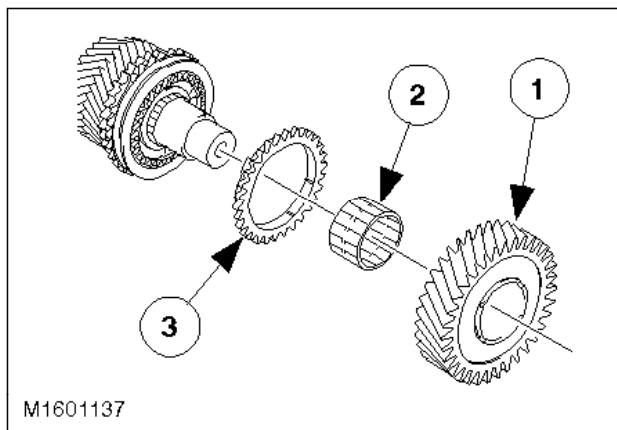

- 38. Detach the reverse gear wheel.

- 1 Gear wheel
- 2 Needle roller bearing
- 3 Synchroniser ring

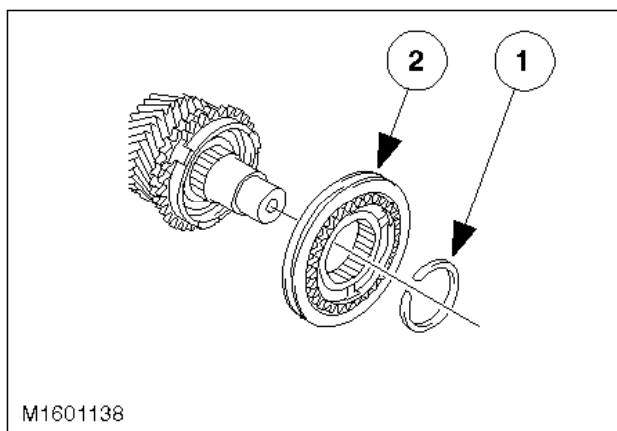

- 39. Detach the fifth/reverse gear synchroniser, complete.

- 1 Circlip
- 2 Gear synchroniser

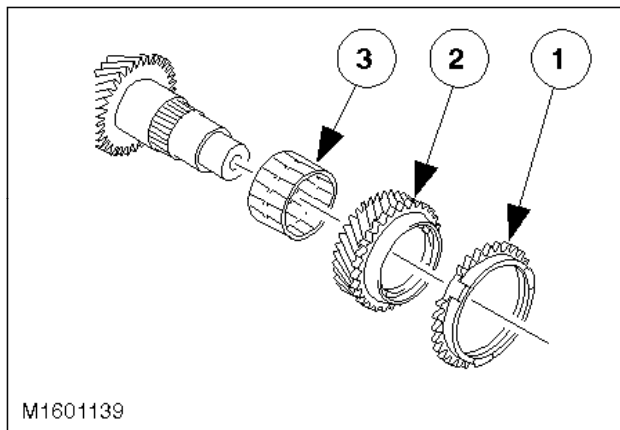

40. Detach the fifth gear wheel together with the synchroniser ring and the needle roller bearing.

- 1 Synchroniser ring
- 2 Gear wheel
- 3 Needle roller bearing

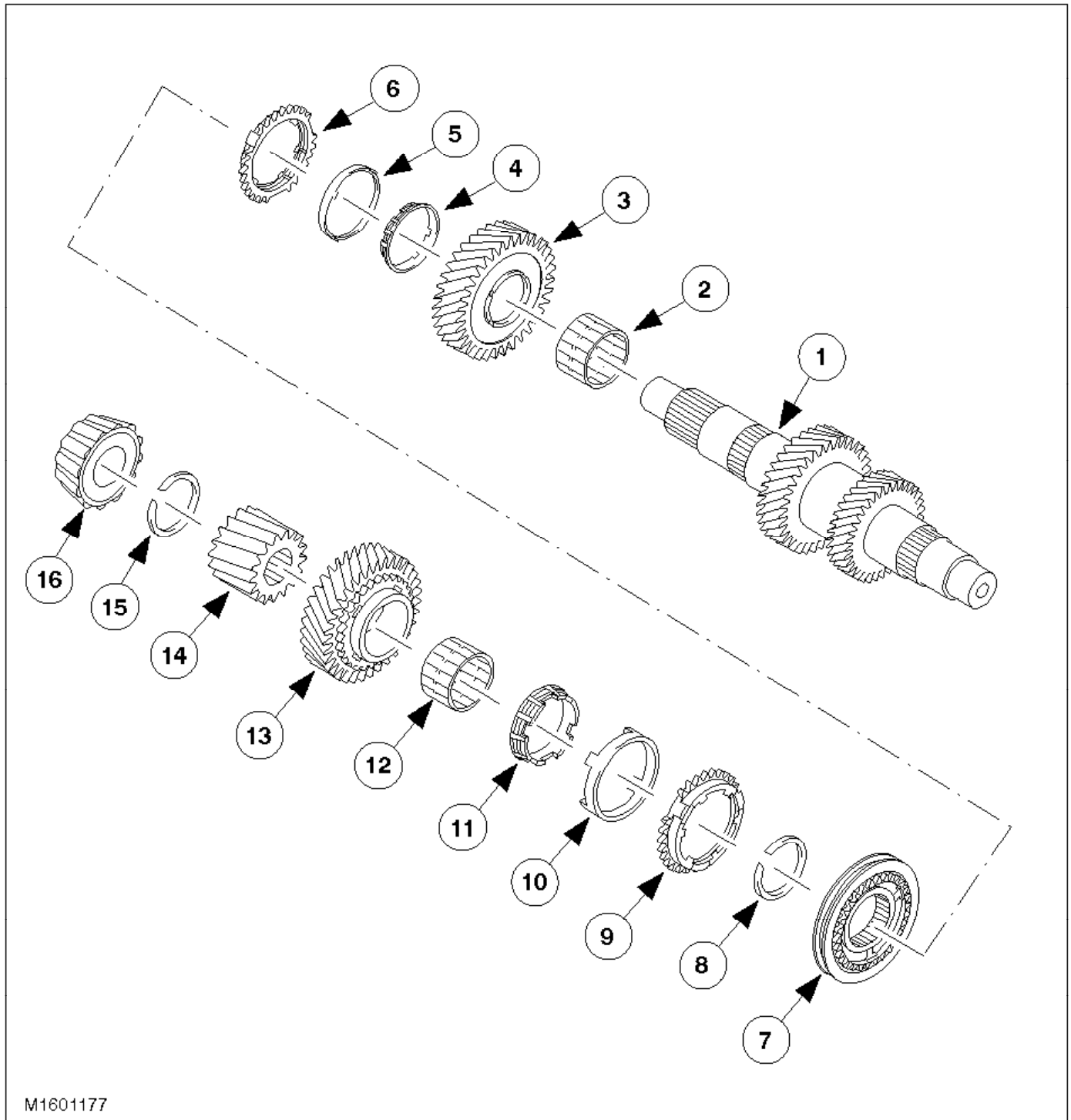

M1601177

Layout of output shaft

Item	Description
1	Output shaft
2	2nd gear needle roller bearing
3	2nd gear wheel
4	2nd gear inner synchroniser ring
5	2nd gear synchroniser cone
6	2nd gear outer synchroniser ring
7	Gear synchroniser assembly (1st/2nd gear)

8	Circlip
9	1st gear outer synchroniser ring
10	1st gear synchroniser cone
11	1st gear inner synchroniser ring
12	1st gear needle roller bearing
13	1st gear wheel
14	Output pinion
15	Circlip
16	Taper roller bearing

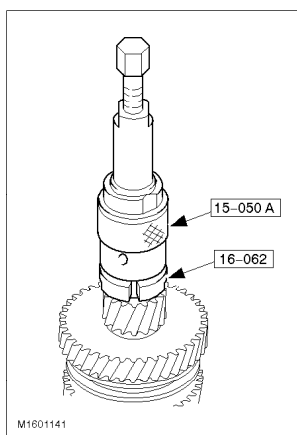

41. Pull off the taper roller bearing on the clutch side.

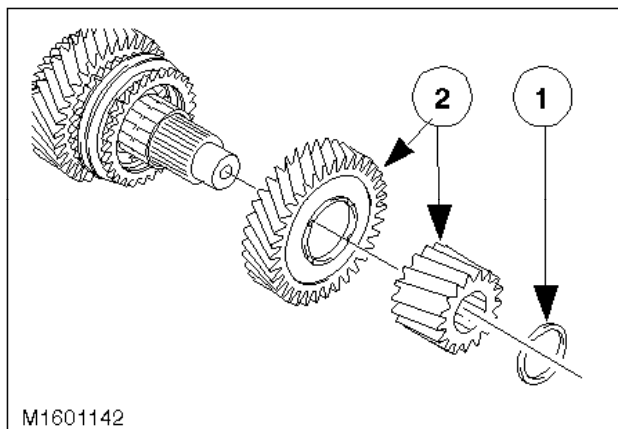

CAUTION:

Mark the output pinion for re-assembly. The output shaft and output pinion are paired and can be renewed together.

42. Press the output pinion and the first gear wheel off together.
- 1 Circlip
 - 2 Pinion with first gear wheel.

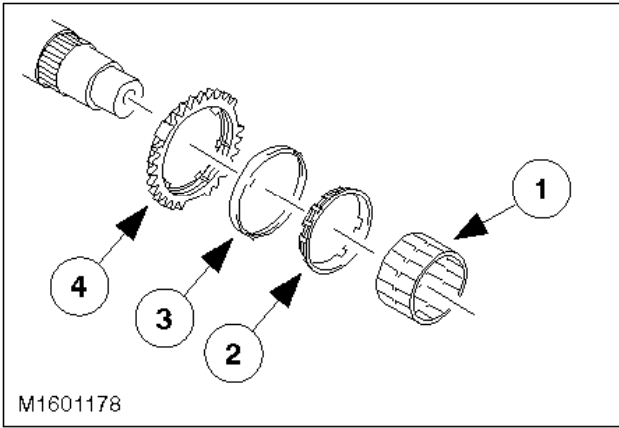

43. Detach the double synchroniser and the needle roller bearing together.

- 1 Needle roller bearing
- 2 Inner synchroniser ring
- 3 Synchroniser cone
- 4 Outer synchroniser ring

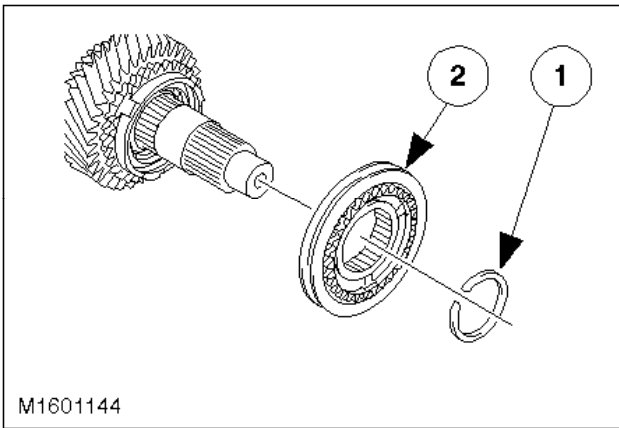

44. Remove the 1st/2nd gear synchroniser.

- 1 Circlip
- 2 Gear synchroniser

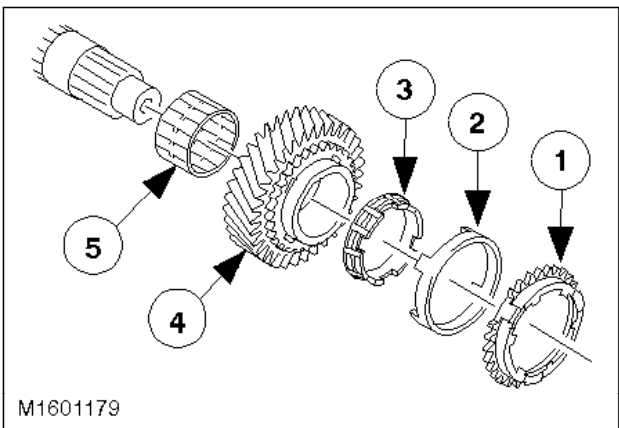

45. Detach the second gear wheel.

- 1 Outer synchroniser ring
- 2 Synchroniser cone
- 3 Inner synchroniser ring
- 4 Gear wheel
- 5 Needle roller bearing

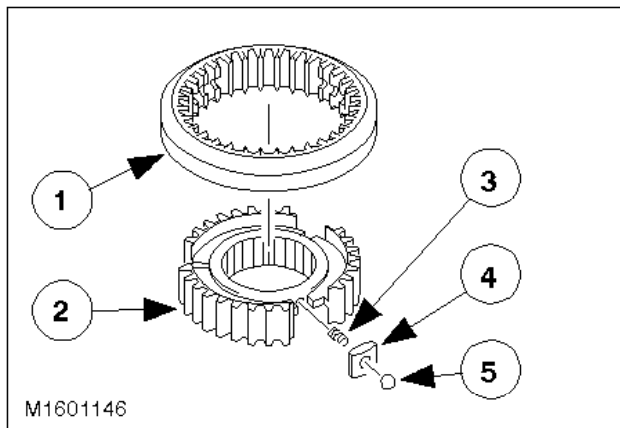

Note:

Mark the installation position of the selector ring.

- 46. Dismantle the gear synchroniser.



CAUTION:

Carefully pull the selector ring off the gear synchroniser hub; the detent balls are spring-tensioned.

- 1 Selector ring
- 2 Gear synchroniser hub
- 3 Compression spring
- 4 Blocker bar
- 5 Detent ball

Assemble

- 47. Carefully clean and check all parts before reassembly.



CAUTION:

Before installing, immerse the double synchronisers in a fluid bath (WSD-M2C200-C) and lubricate all moving parts.

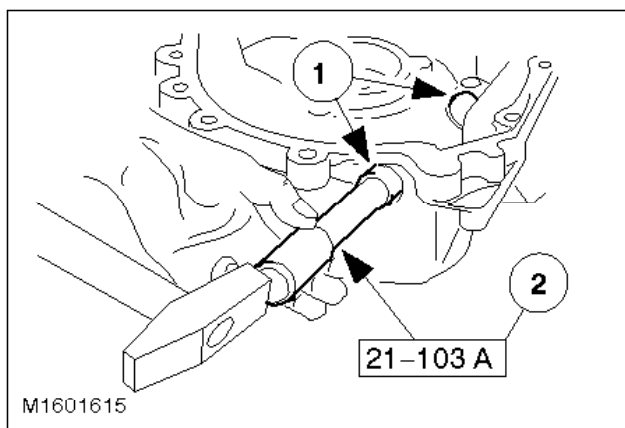

- 48. Install the selector shaft ball sleeves.

- 1 Insert the inner ball sleeve first.
- 2 Drive in the ball sleeves using the special tool.

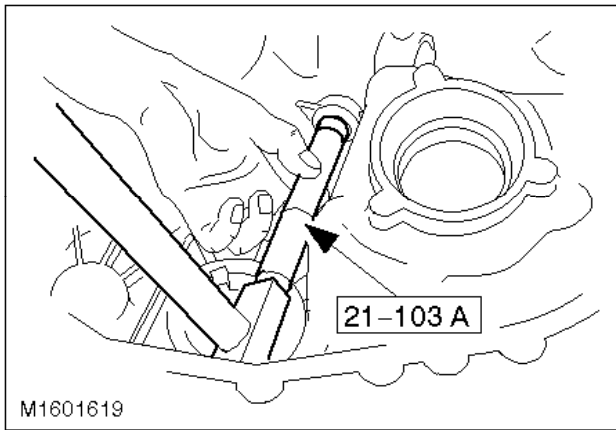

49. Insert the inner selector shaft bearing sleeve.

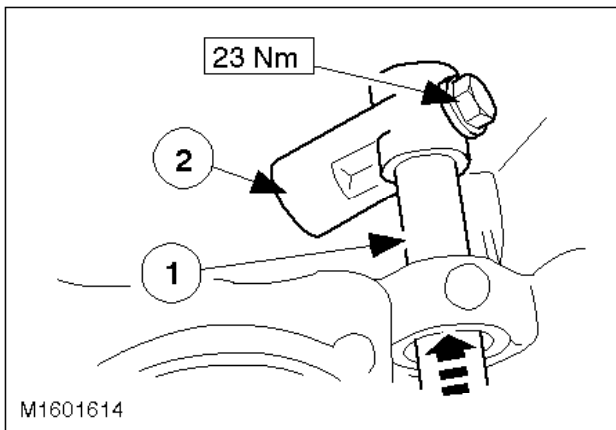

50. Install the selector shaft.

- 1 Install the selector shaft.
- 2 Locate the ball socket in position and tighten.

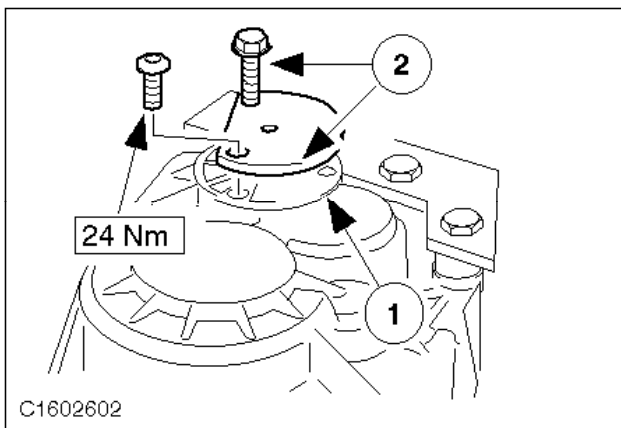

51. Install the reverse gear idler shaft.

- 1 Apply sealer to the mating face of the reverse gear idler shaft.
- 2 Locate the reverse gear idler shaft in position with the locating bolt and drive in.
- 3 Remove the locating bolt and screw in the original bolts.

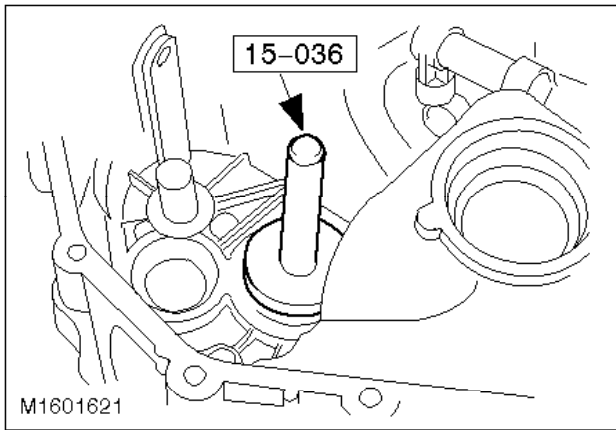

CAUTION:

The pressure applied must not exceed 15 kN.

- ⌚ 52. Install the bearing rings on the transmission housing side.
 - Warm the housing locally with a hot-air blower to about 80°C.
 - Cool the bearing rings with a refrigerant spray and insert.
 - Install the bearing rings using the press:
 - Input shaft using 15-036
 - Output shaft using 15-036
 - Differential using 14-024
- 53. Shim of required thickness:
 - Input shaft: 1,00 mm
 - Output shaft: 1,00 mm
 - Differential: 1,10 mm

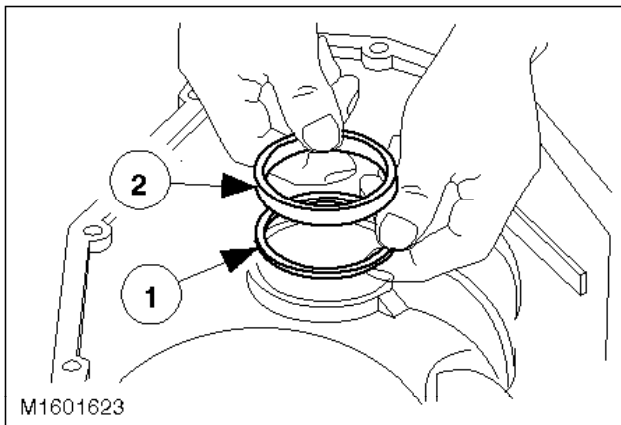

- ⌚ 54. Install the measuring shims and bearing rings from the clutch side of the transmission housing half.
 - Warm the housing area to about 80°C.
 - Cool the bearing rings with refrigerant spray.
 - 1 Insert the shims of the required thickness.
 - 2 Insert the bearing rings.



CAUTION:

The pressure applied must not exceed 15 kN.

Note:

Install using the press, do not drive it in.

Bearing rings from:

Input shaft using 14-010
Output shaft using 15-036
Differential using 14-024

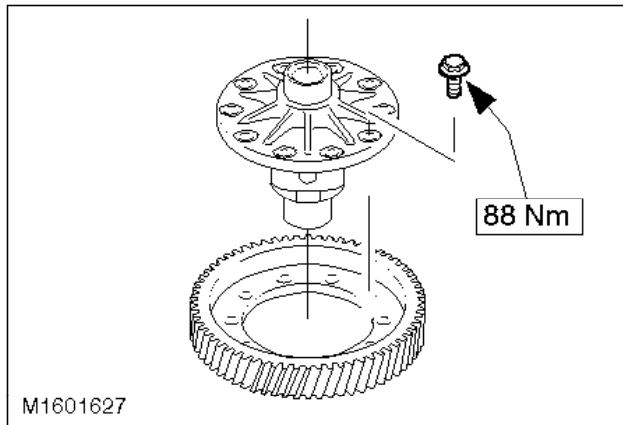

Assemble differential

Note:

Do not lubricate taper roller bearings that are to be re-used. New taper roller bearings can be installed untreated. Carefully clean and check all parts and coat with transmission fluid before assembly.

55. Fit the crown wheel to the differential.

Tighten the crown wheel evenly, working diagonally.

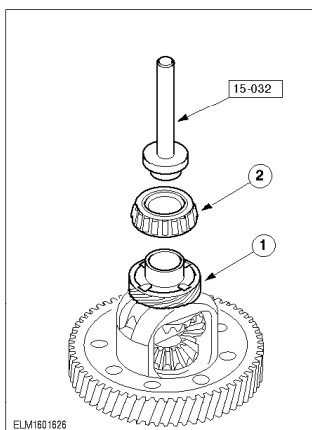

Note:

The speedometer worm gear or the sensor ring of the vehicle speed sensor must engage in the recess on the housing.

56. Press on the taper roller bearing.

- 1 Install the speedometer worm gear.
- 2 Press on the taper roller bearing using the press and the Special Tool.

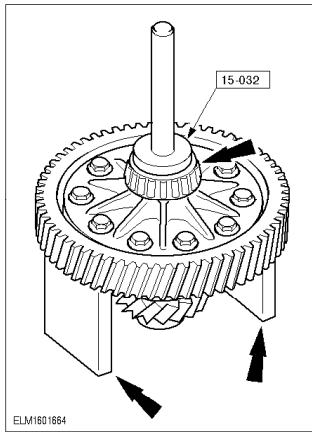

CAUTION:

Do not use the taper roller bearing as a support.

57. Install the taper roller bearing (on the side of the crown wheel).
- Support the differential below the crown wheel.
 - Press on the taper roller bearing with the special tool.

Assemble input shaft

Note:

Do not oil the taper roller bearing which is being reassembled. New taper roller bearings can be assembled unoled.

58. Carefully clean and check all parts before reassembly. Lubricate all moving parts with transmission fluid (WSD-M2C200-C).

Note:

From model year '95 a double synchroniser is installed for 1st, 2nd and 3rd gears.



CAUTION:

The inner synchroniser ring and the synchroniser cone must be handled with great care.



CAUTION:

Place the double synchronisers in an oil bath (WSD-M2C200-C) before fitting them.

The layout and assembly of the single synchroniser for 3rd gear is identical to that for 4th gear.

The steps described below refer to the double synchroniser. Refer to the Technical Data table for renewal of synchroniser parts.

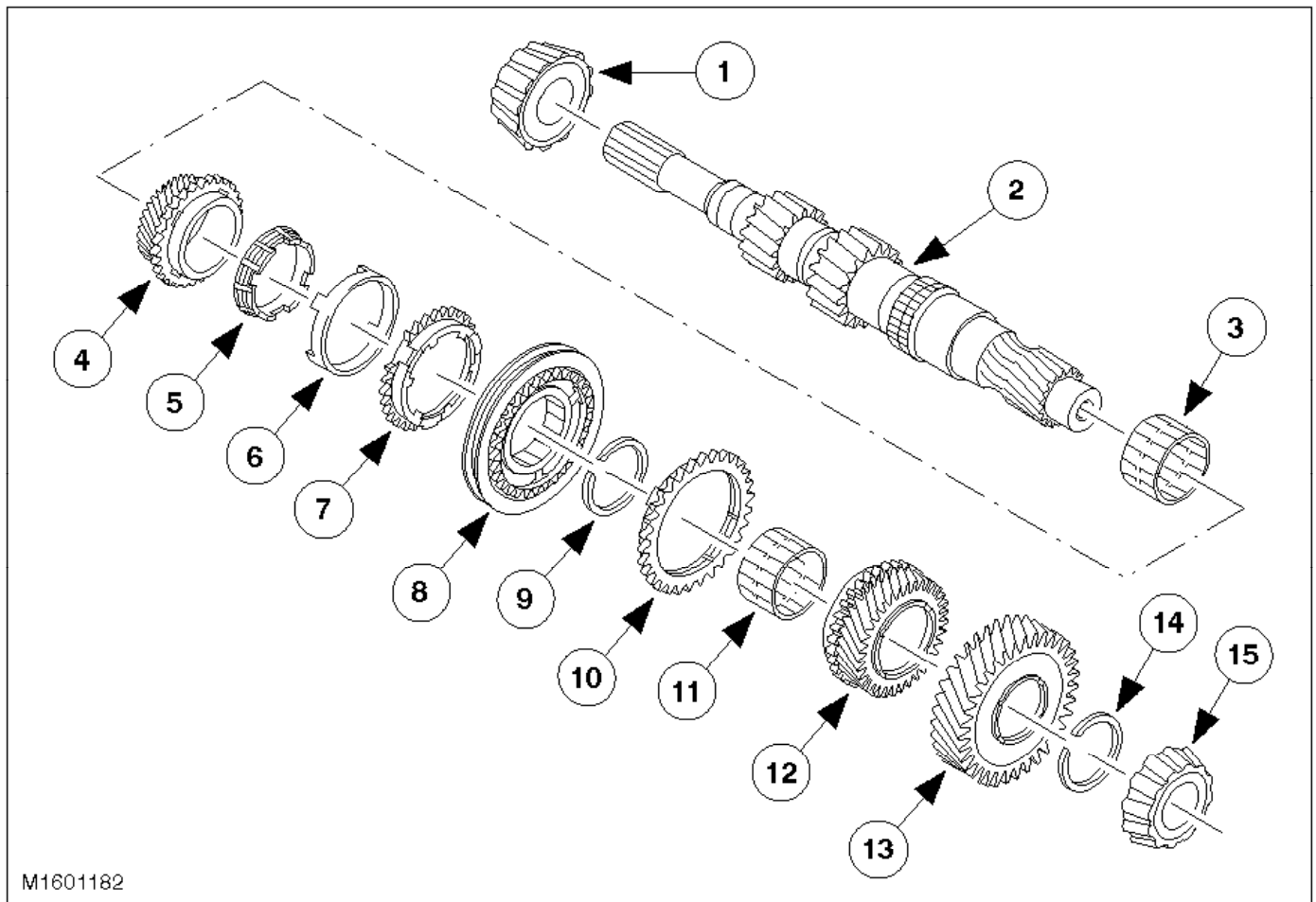

Layout of input shaft

Item	Description
1	Taper roller bearing
2	Input shaft
3	3rd gear wheel needle roller bearing
4	3rd gear wheel
5	3rd inner synchroniser ring
6	3rd gear synchroniser cone
7	3rd gear outer synchroniser ring
8	3rd/4th gear synchroniser assembly
9	Circlip
10	4th gear synchroniser ring
11	4th gear needle roller bearing
12	4th gear wheel
13	Fifth gear wheel
14	Circlip

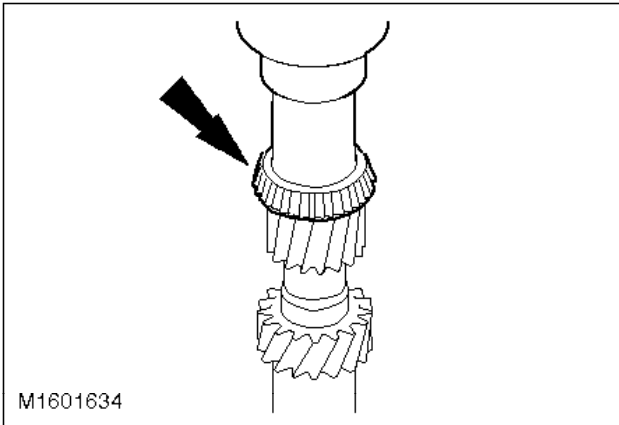

69. Press on the taper roller bearing on the clutch side.

Press on the taper roller bearing using a suitable tube.

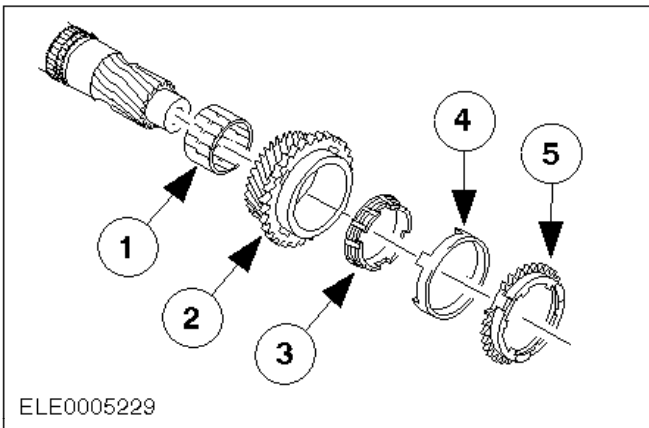

Note:

See previous step.

60. Assemble the third gear wheel.

- 1 Needle roller bearing
- 2 3rd gear wheel
- 3 Inner synchroniser ring
- 4 Synchroniser cone
- 5 Outer synchroniser ring

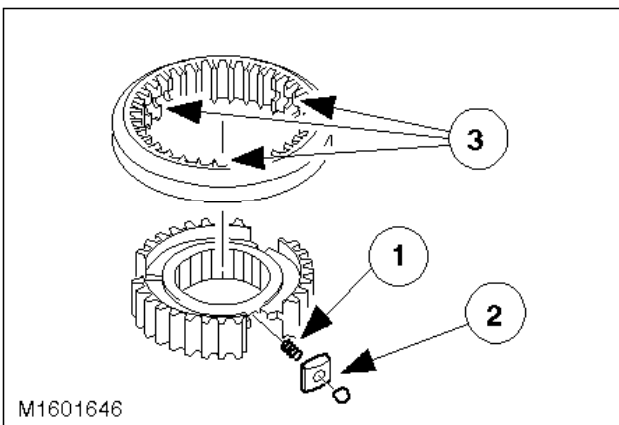

61. Assemble the 3rd/4th gear synchroniser.

- 1 Insert the compression springs.
- 2 Insert the blocker bar, together with the detent balls, next to the spring.
- 3 Align the selector ring correctly and push it on.

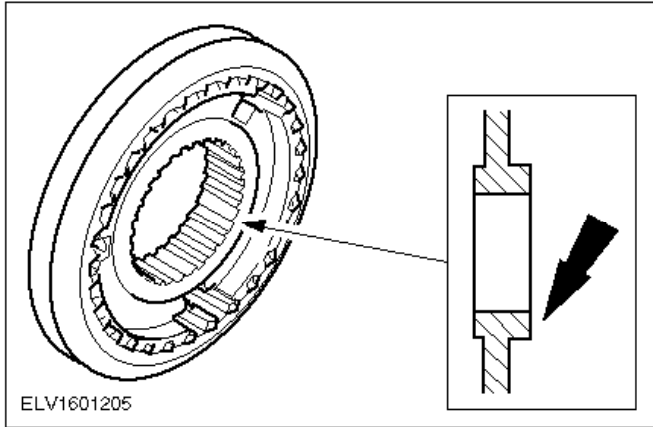

Note:

Install the synchroniser hub with the large collar facing out and the ring groove facing the small collar.

62. Installation position of the third/fourth gear synchroniser.

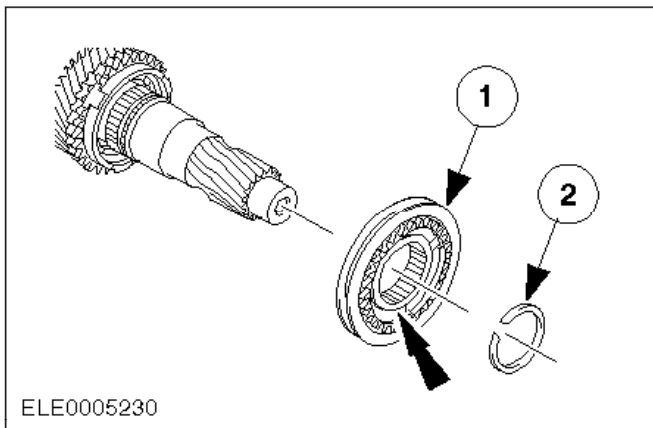

63. Install the third/fourth gear synchroniser.

Note:

Installation position (see previous step).

- 1 Install the gear synchroniser assembly.
- 2 Fit a new circlip.

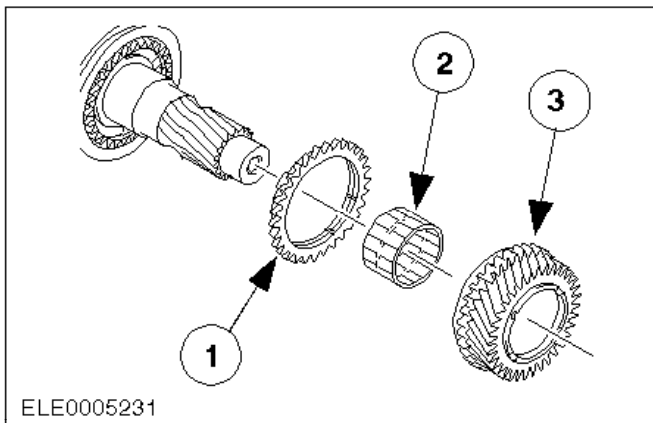

64. Fit the fourth gear wheel.

- 1 Synchroniser ring
- 2 Needle roller bearing
- 3 4th gear wheel

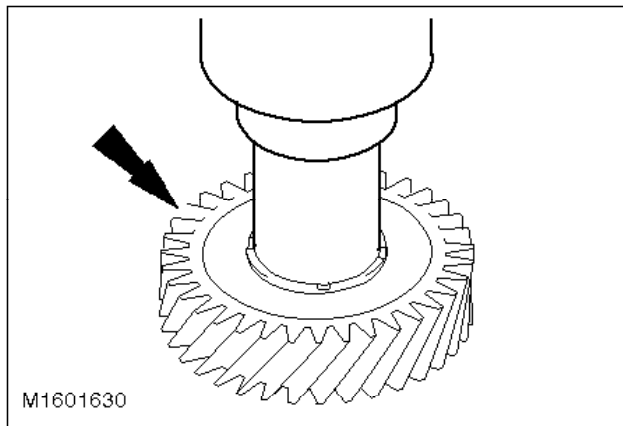

65. Press on the fifth gear wheel.
- Press on the fifth gear wheel using a suitable tube and press.
 - Fit a new circlip.

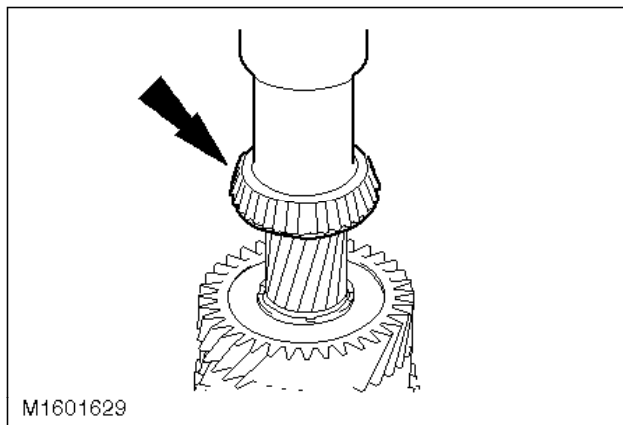

66. Press on the taper roller bearings on the transmission and clutch sides (taper roller bearing on the transmission side is shown).
- Press the taper roller bearing on using a suitable tube.

Assemble output shaft

Note:

Do not lubricate the taper roller bearings which are being reassembled. New taper roller bearings can be installed unoled.

67. Carefully clean and check all components and lubricate with transmission fluid (WSD-M2C200-C) before assembly.

Note:

From model year '95 a double synchroniser is installed for 1st, 2nd and 3rd gears.



CAUTION:

The inner synchroniser ring and the synchroniser cone must be handled with great care.



CAUTION:

Place the double synchronisers in an oil bath (WSD-M2C200-C) before fitting them.

The layout and assembly of the single synchroniser for 3rd gear is identical to that for 4th gear. The steps described below refer to the double synchroniser. Refer to the Technical Data table for renewal of synchroniser parts.

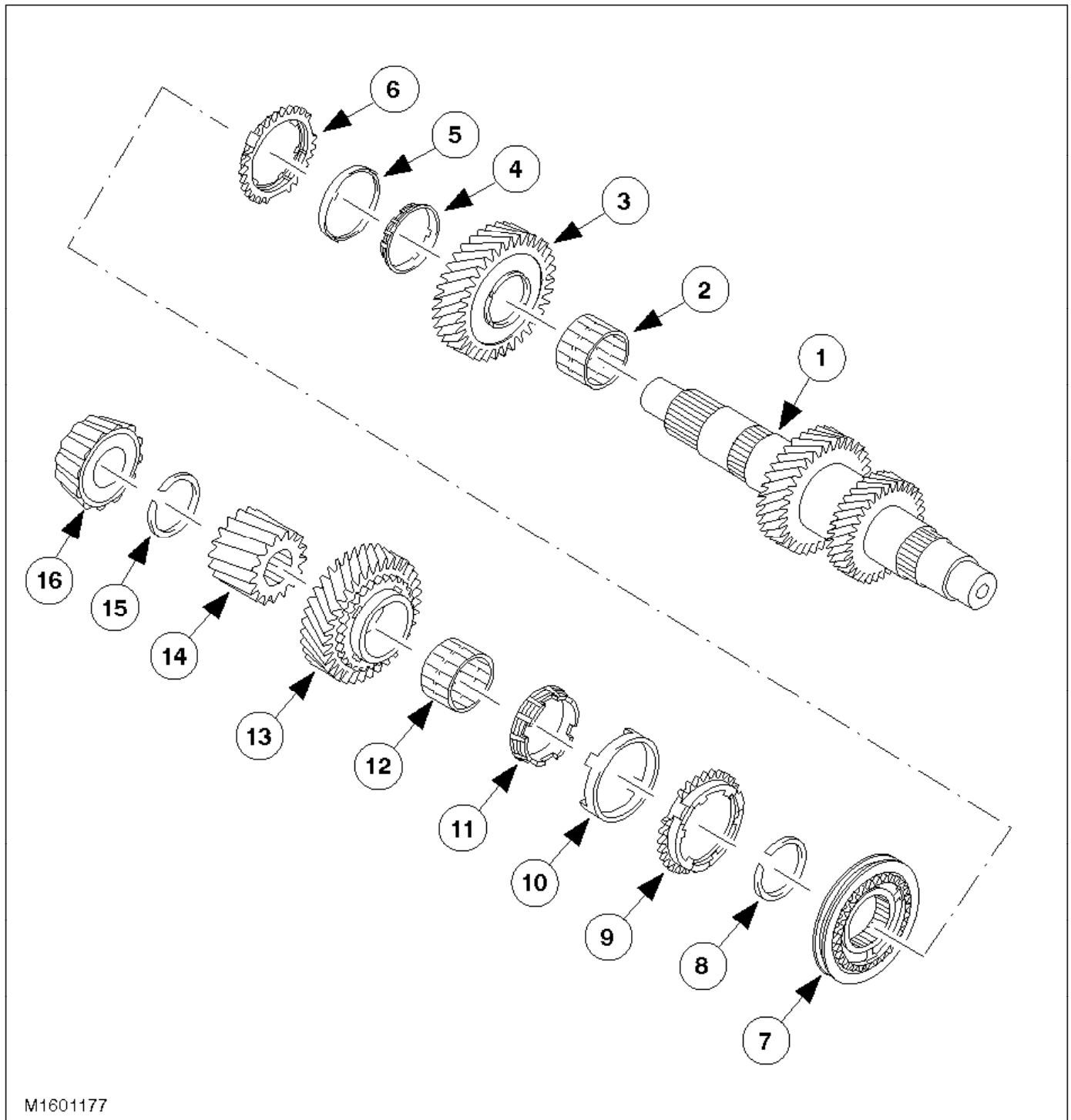

M1601177

Layout of the output shaft

Item	Description
1	Output shaft
2	2nd gear needle roller bearing
3	2nd gear wheel
4	2nd gear inner synchroniser ring
5	2nd gear synchroniser cone

6	2nd gear outer synchroniser ring
7	1st/2nd gear synchroniser assembly
8	Circlip
9	1st gear outer synchroniser ring
10	1st gear synchroniser cone
11	1st gear inner synchroniser ring
12	1st gear needle roller bearing
13	1st gear wheel
14	Output pinion
15	Circlip
16	Taper roller bearing

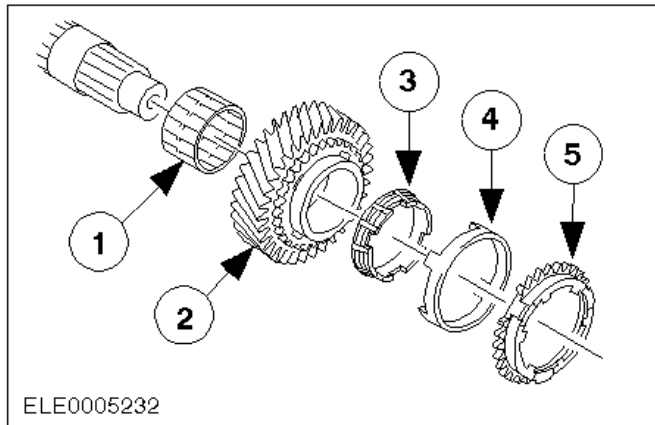

Note:

See the following step.

68. Assemble the second gear wheel.

- 1 Needle roller bearing
- 2 2nd gear wheel
- 3 Inner synchroniser ring
- 4 Synchroniser cone
- 5 Outer synchroniser ring

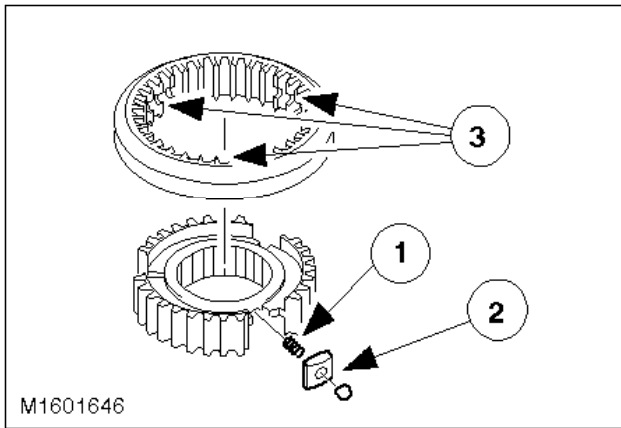

Note:

Mark the installation position

- 69. Assemble the 1st/2nd gear synchroniser.
 - 1 Insert the compression springs.
 - 2 Fit the blocker bar and the gear synchroniser hub ball detents next to the spring.
 - 3 Align the selector ring correctly and push it on.

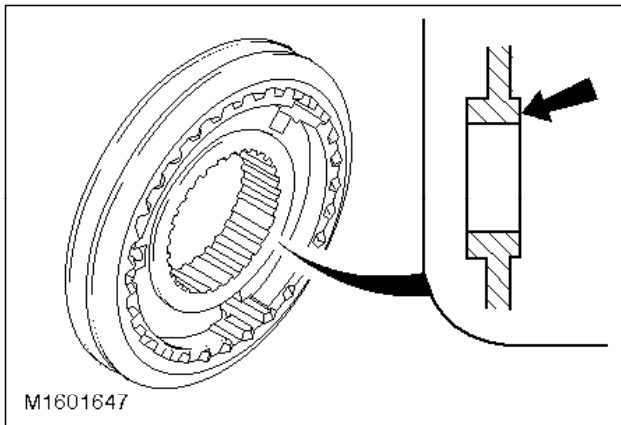

Note:

The small collar on the gear synchroniser hub must point outwards.

- 70. Installation position of the first/second gear synchroniser.

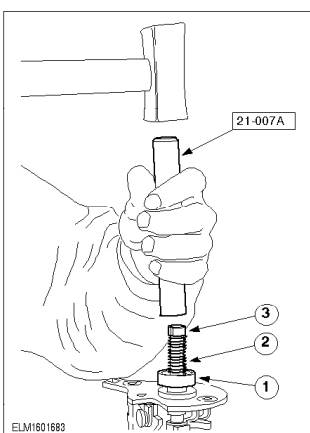

Note:

Installation position (see previous step)

- 71. Assemble the 1st/2nd gear synchroniser.

- 1 Install the gear synchroniser assembly.
- 2 Fit a new circlip.

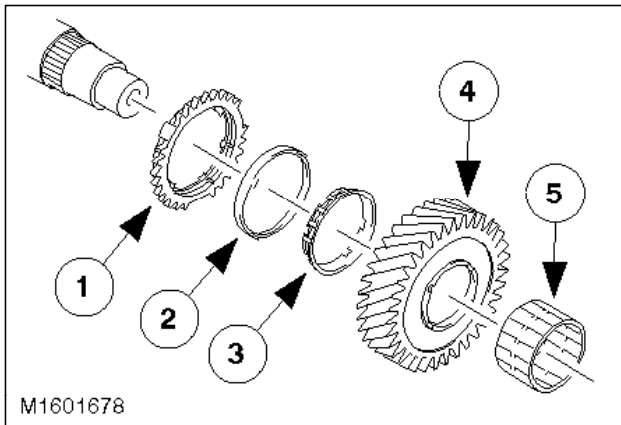

Note:

See previous step.

72. Assemble first gear wheel with double synchroniser.

- 1 Outer synchroniser ring
- 2 Synchroniser cone
- 3 Inner synchroniser ring
- 4 1st gear wheel
- 5 Needle roller bearing

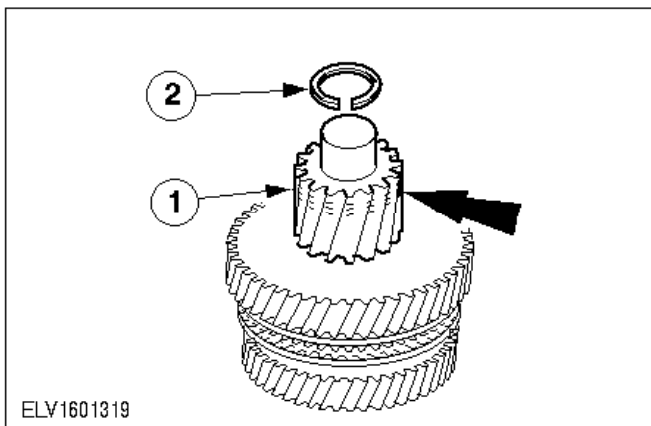

CAUTION:

The output pinion can only be placed on the splines in one position.

73. Press on the output pinion.

- 1 Press on the output pinion using a suitable tube and press.
- 2 Fit a new circlip.
 - Fit the output pinion with the mark facing upwards.

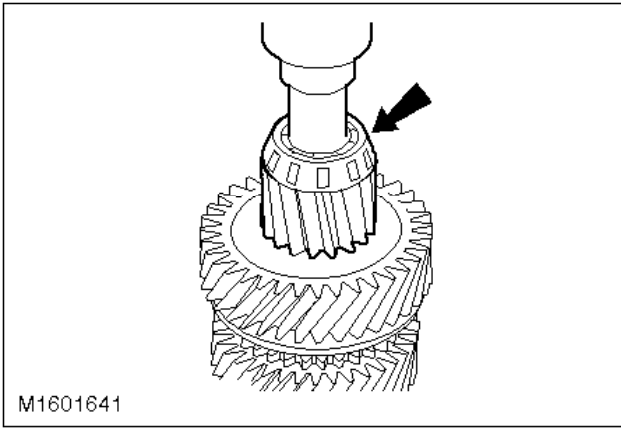

74. Press on the taper roller bearing.

Press on the taper roller bearing using a suitable tube and press.

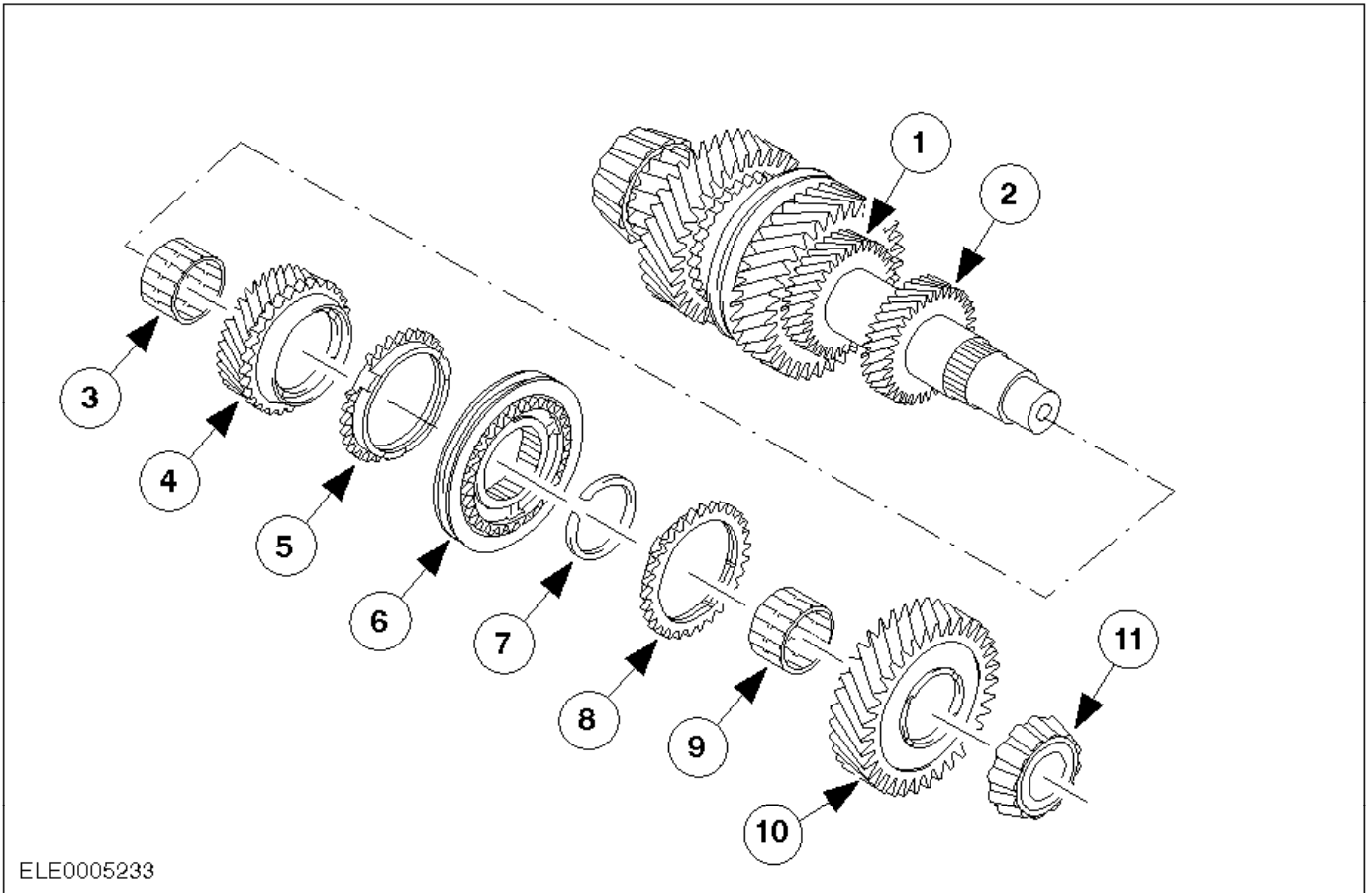

Layout of the output shaft

Item	Description
1	3rd gear wheel
2	3rd gear wheel
3	5th gear wheel
4	5th gear wheel
5	5th gear synchroniser ring
6	Gear synchroniser, complete - (fifth/reverse gear)

7	Circlip
8	Synchroniser ring - reverse gear
9	Needle roller bearing - reverse gear
10	Reverse gearwheel
11	Taper roller bearing

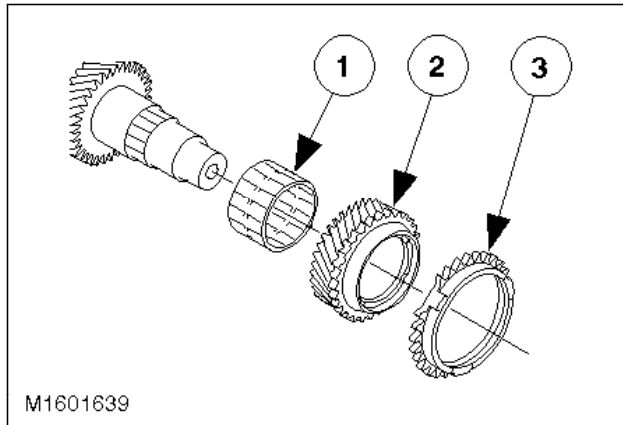

75. Fit the fifth gear wheel together with the synchroniser ring and needle roller bearing.

- 1 Needle roller bearing
- 2 5th gear wheel
- 3 Synchroniser ring

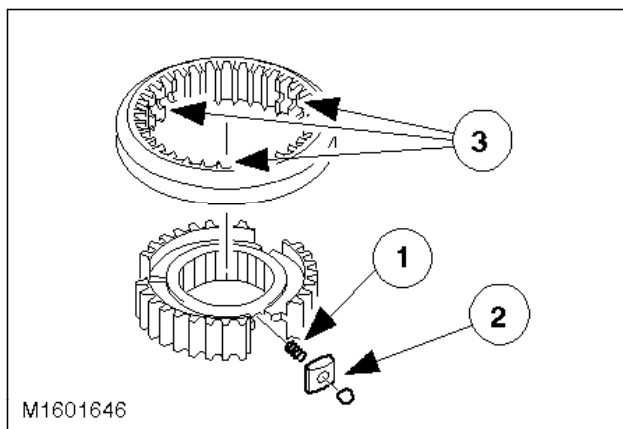

Note:

Mark the installation position

76. Assemble the fifth/reverse gear synchroniser.

- 1 Insert the compression springs.
- 2 Fit the blocker bar and the detent balls next to the spring.
- 3 Align the selector ring correctly and push it on.

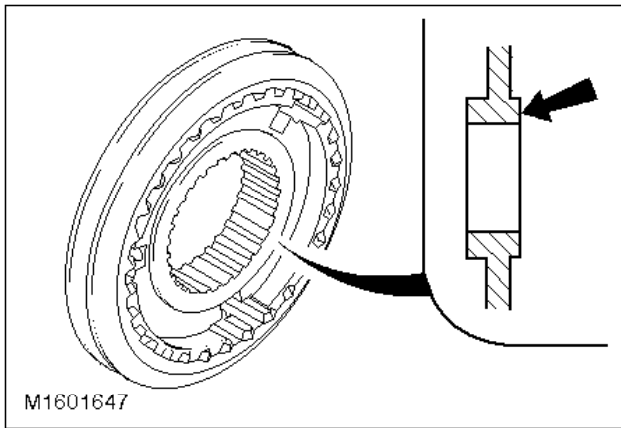

Note:

Install the gear synchroniser hub with the small collar and the ring groove pointing outwards.

- 77. Installation position of gear synchroniser.

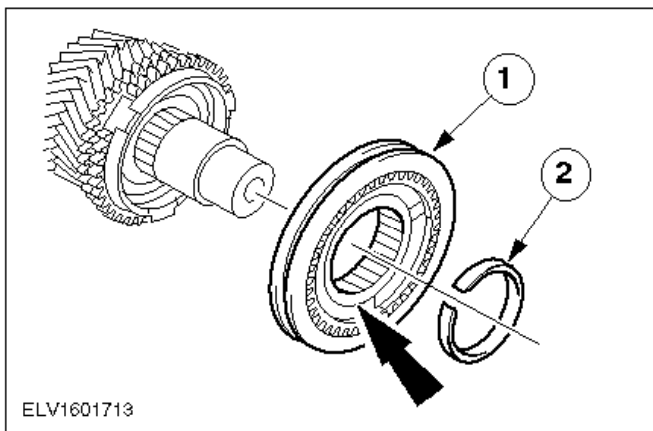

Note:

Install the gear synchroniser hub with the small collar and the ring groove pointing outwards.

- 78. Fit the fifth/reverse gear synchroniser.

- 1 Install the gear synchroniser assembly.
- 2 Attach a new circlip.

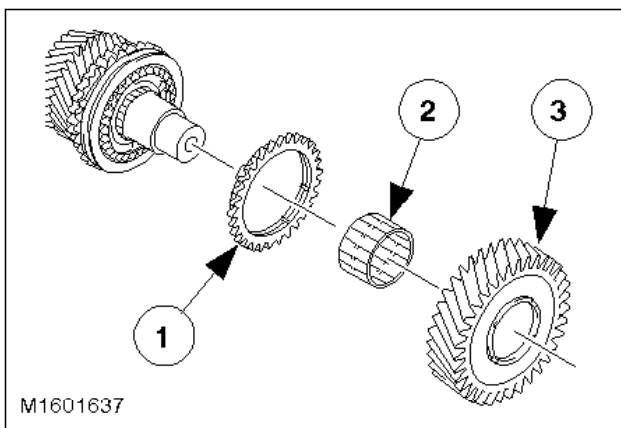

- 79. Assemble the reverse gear wheel.

- 1 Synchroniser ring
- 2 Needle roller bearing
- 3 Reverse gearwheel

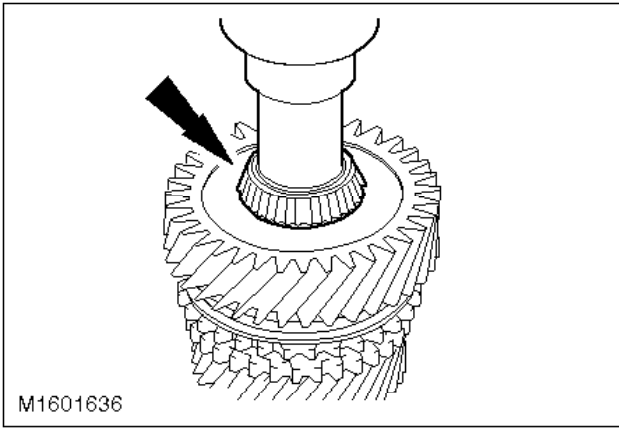

80. Press on the taper roller bearing.

Press on the taper roller bearing using a suitable tube and press.

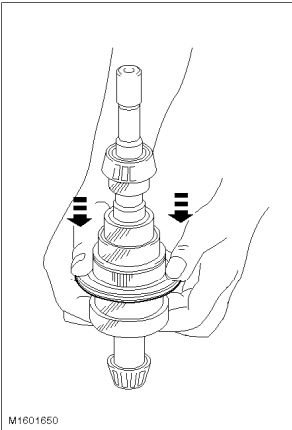

Measure the shims.

Note:

Do not lubricate taper roller bearings that are to be re-used. Fit new taper roller bearings untreated.

81. Insert the input and output shafts into the transmission housing.
- Engage 4th gear.
 - Put the input and output shafts together and insert them in the transmission housing.

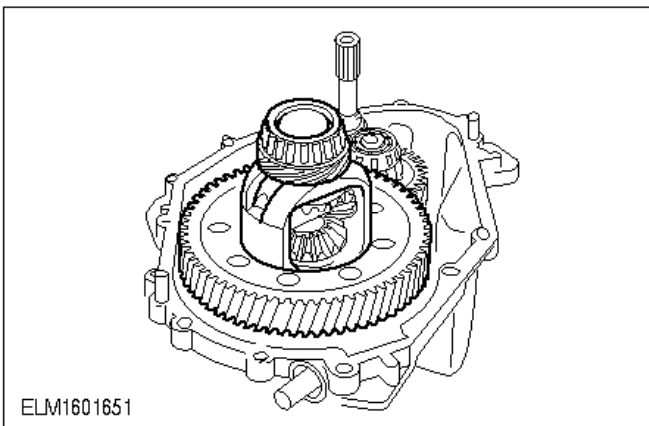

Note:

Do not lubricate taper roller bearings that are to be re-used. Fit new taper roller bearings untreated.

82. Install the differential.

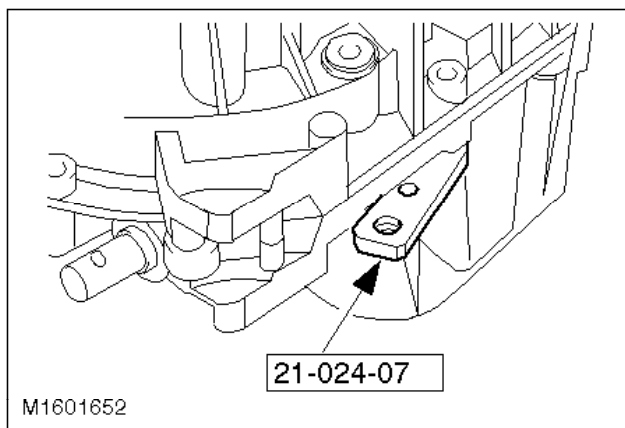

Note:

The mating face must be scrupulously clean.

83. Fit the housing sections on the clutch side.

Fit the special tool and the longer bolt.

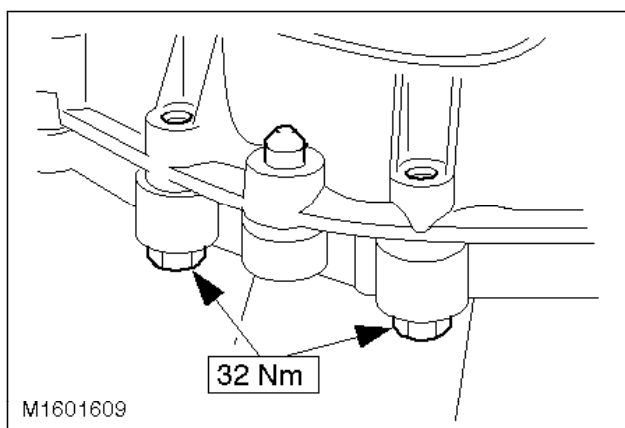

84. Assemble the transmission housing sections on the clutch side.

Tighten the 16 flange bolts evenly.

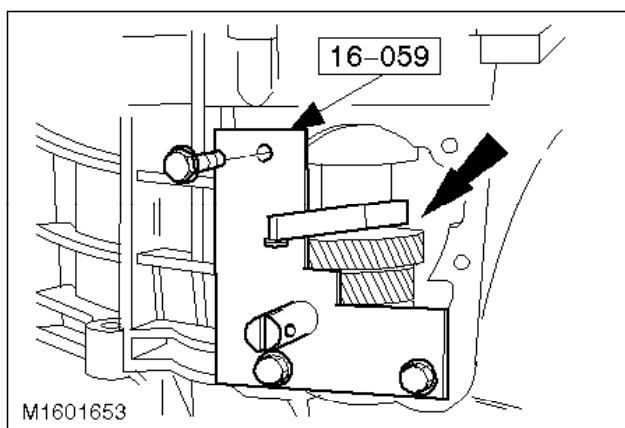

85. Fit the special tool.

Fit the measuring bar to the 4th gear wheel.

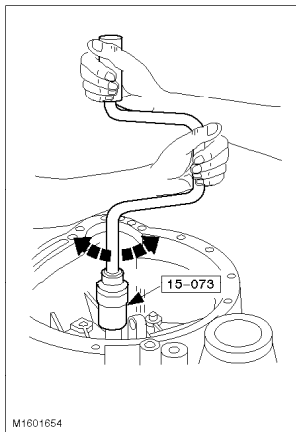

86. Prepare the input shaft for measurement.

Turn the input shaft back and forth about 20 times so that the bearings settle.

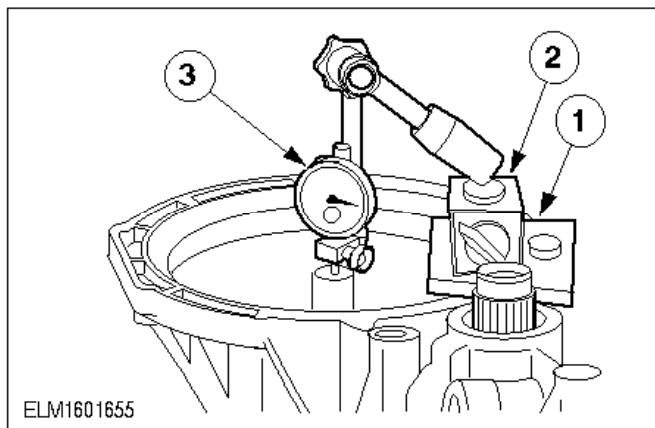

87. Fit the dial gauge.

- 1 Fit a steel mounting plate (eg 21-146) to the transmission.
- 2 Install the magnetic fixture.
- 3 Set the dial pointer to "0".

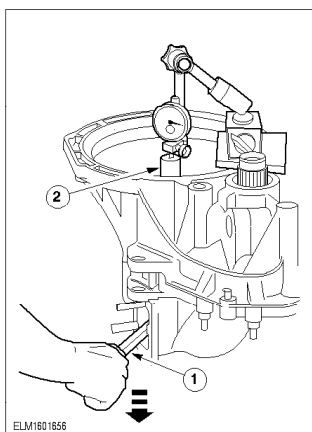

88. Measure the input shaft end float.

Note:

Carry out the measurement preparations and the measurement three times and calculate the average value.

- 1 Raise the input shaft using the lever.
 - 2 Make a note of the result (eg 0,22 mm).
- For example: $0.22 \text{ mm} + 0.23 \text{ mm} + 0.21 \text{ mm}$ divided by three = 0.22 mm.

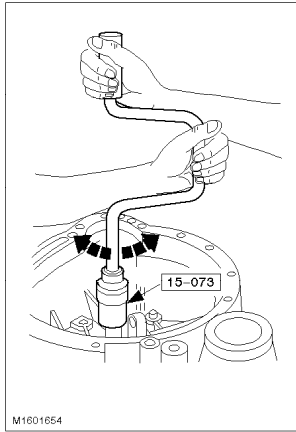

89. Prepare the output shaft for measurement.

Turn the input shaft back and forth about 20 times so that the bearings settle.

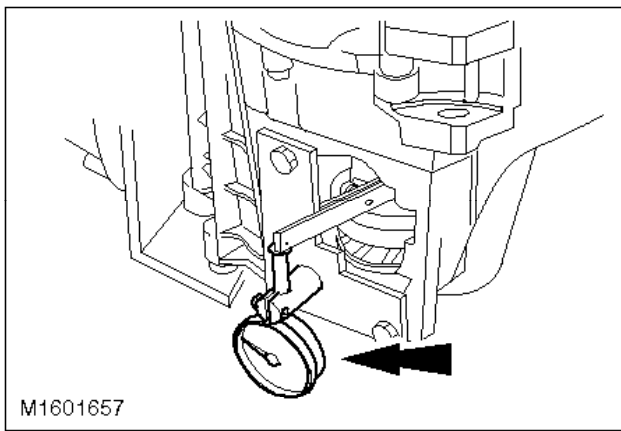

90. Prepare the output shaft for measurement.

- Fit the dial gauge.
- Set the dial gauge to "0".

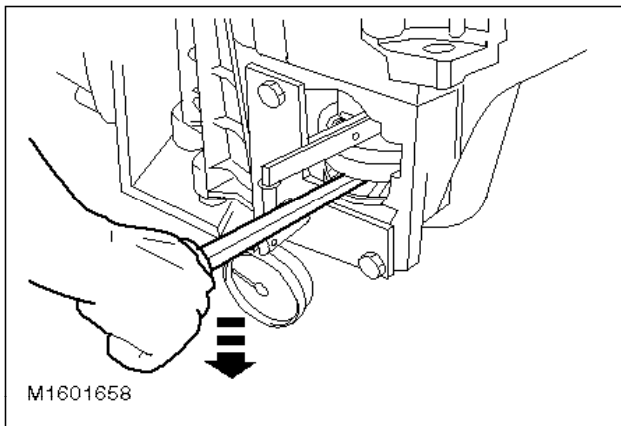

91. Measure the output shaft end float.

Note:

Carry out the measurement preparations and the measurement three times and calculate the average value.

- Raise the output shaft using the lever and make a note of the result, eg, 0.32 mm.
- For example: $0.32 \text{ mm} + 0.34 \text{ mm} + 0.33 \text{ mm}$ divided by three = 0.33 mm.

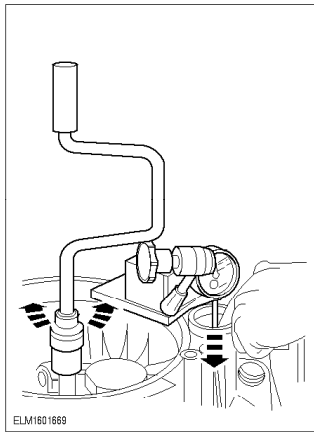

92. Prepare the differential for measurement.

- Turn the input shaft approx. 20 times back and forth and press down the differential at the same time.
- Fit the dial gauge and set it to "0".

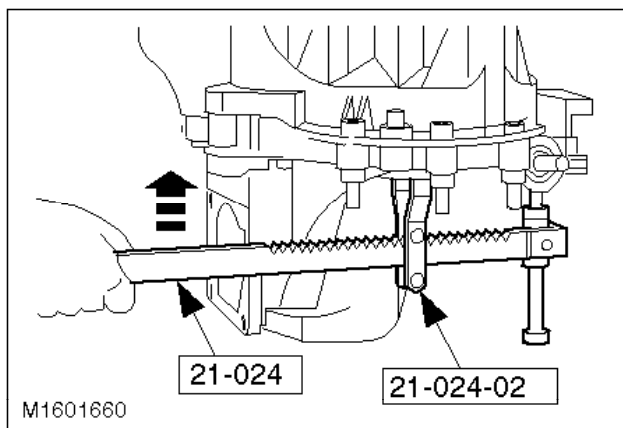

Note:

Carry out the measurement preparations and the measurement three times and calculate the average value.

93. Measure the differential end float.

- Lift up the differential using the special tool and make a note of the result, eg 0,34 mm
- For example: 0.34 mm + 0.36 mm + 0.37 mm divided by three = 0.36 mm.

Measure the shim thickness to be inserted (mm dimensions)

Description	Input Shaft	Output shaft	Differential
Measuring shim in mm	1,00	1,00	1,10
Measured end float (mm)	+ 0,22	+ 0,33	+ 0,36
Dimension for pre-tension (mm)	-	+ 0,13	+ 0,33
End float (mm)	- 0,05	-	-
Required thickness of shim	= 1,17	= 1,46	= 1,79
Adjustment shim availability (mm)	1,15-1,71 (in 0,01 mm steps)	1,31-1,91 (in 0,02 mm steps)	1,40 - 2,20 (0,05 steps)

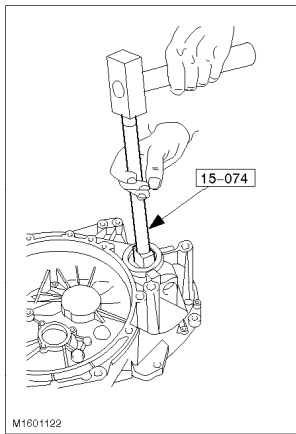

Note:

Fit the special tool in the transmission recesses.

- 94. Remove the differential and the bearing rings.
 - From the input shaft
 - From the differential

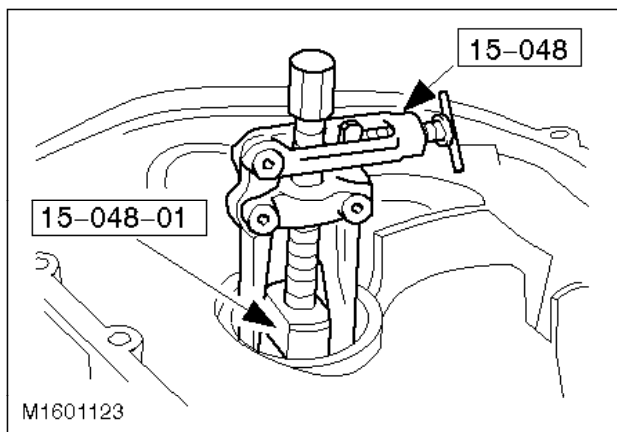

Note:

Fit the special tool in the transmission recesses.

- 95. Remove the input shaft bearing and the shim.

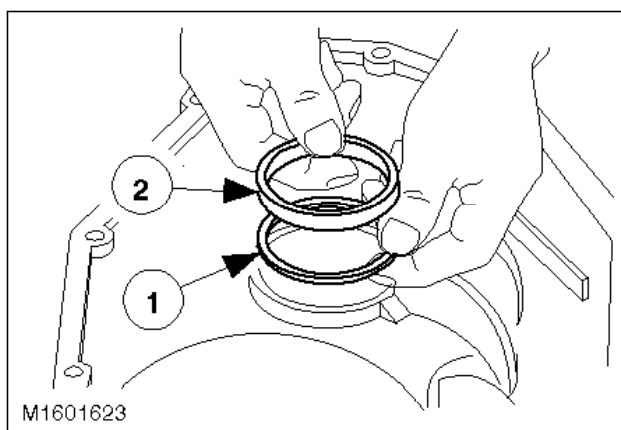

- 96. Insert the shims and the bearing rings into the housing section on the clutch side.
 - Warm the housing area to about 80°C.
 - Cool the bearing rings with refrigerant spray.
 - 1 Insert the shims of the required thickness.
 - 2 Insert the bearing rings.



CAUTION:

The pressure applied must not exceed 15 kN.

Note:

Install using the press, do not drive it in.

Bearing rings from the:

Input shaft using 14-010

Output shaft using 15-036

Differential using 14-024

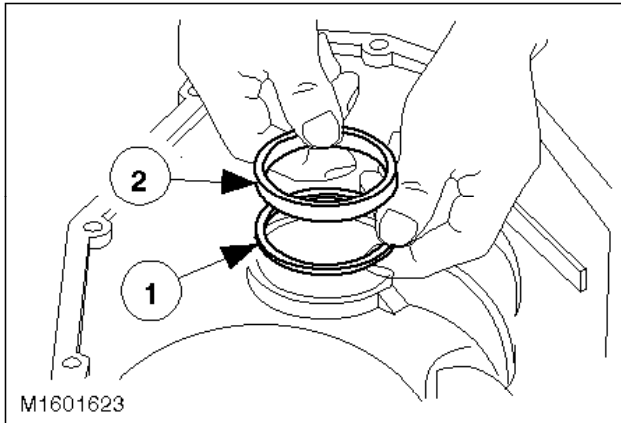

97. Install the shims and the bearing rings.

1 Install the shims of the required thickness.

2 Bearing rings for the:

Install the input shaft, output shaft and differential as described in the steps.

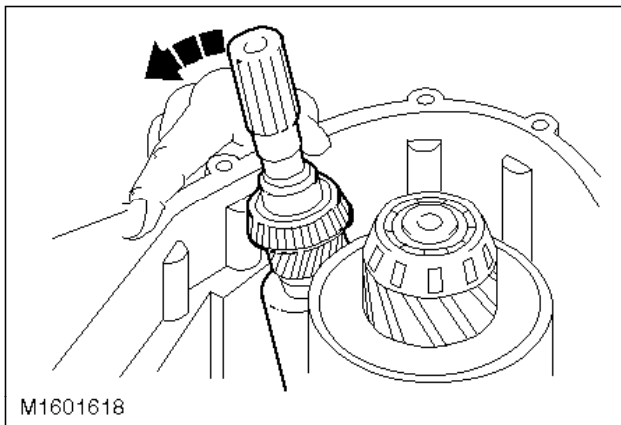

Note:

Lubricate the taper roller bearings.

98. Install the input and output shafts together.

Swivel the input shaft to one side and insert the reverse gear idler (for order of installation, see the following step).

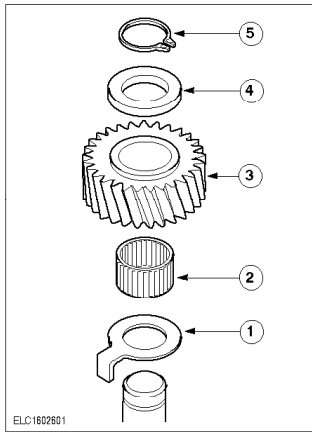

99. Order of installation for the reverse gear idler.

- 1 Lower thrust washer.
- 2 Needle roller bearing
- 3 Reverse gear idler.
- 4 Upper thrust washer
- 5 Circlip

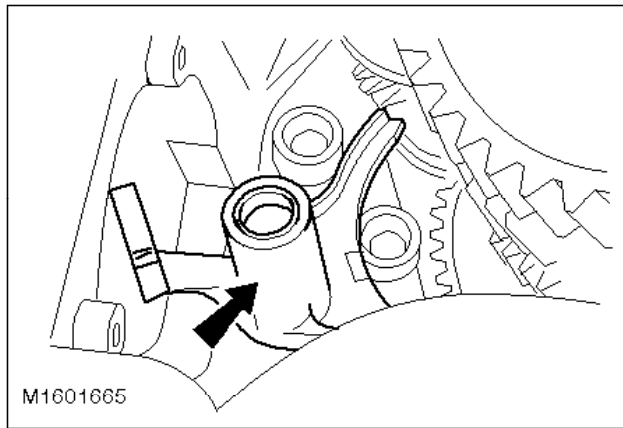

100. Fit the selector fork.

- Put the 4th gear selector ring in neutral.
- Insert the fifth/reverse gear selector fork and swivel to one side.

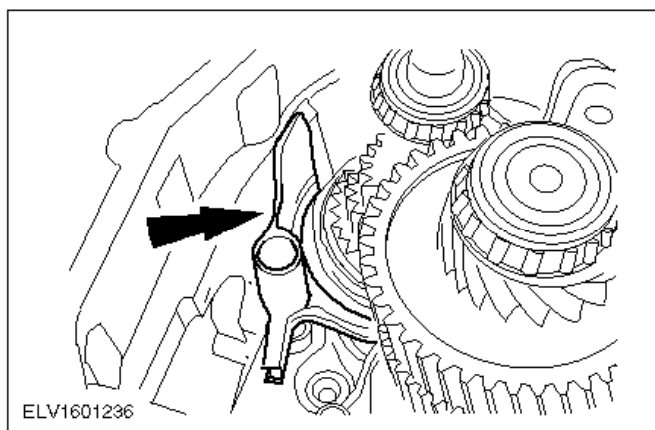

101. Install the 3rd/4th gear selector fork.

- Swivel the fifth/reverse gear selector fork back into position.

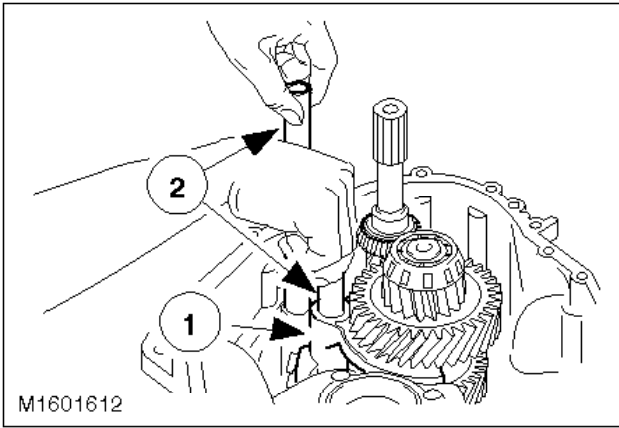

Note:

When correctly positioned all the selector rods are at the same height.

- 102. Install the 1st/2nd gear selector fork and rods.

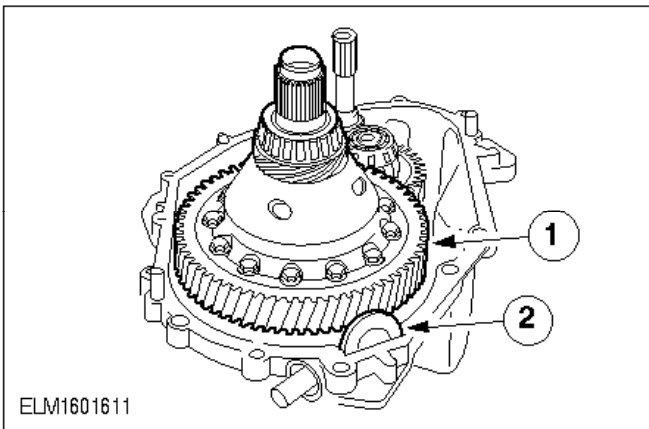

- 103. Install the differential.

- 1 Install the differential.
- 2 Install the clean magnetic disc in the slot provided.

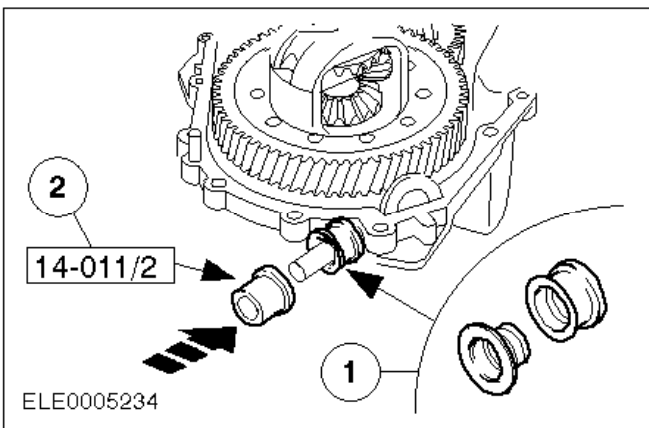

Fit the selector shaft oil seal.

Note:

The selector shaft must be clean and free of burrs.

- 104. Fit the selector shaft oil seal.

Push the selector shaft inwards.

- 1 Push the oil seal and the assembly sleeve onto the selector shaft.

- 2 Drive in the oil seal just up to the stop.

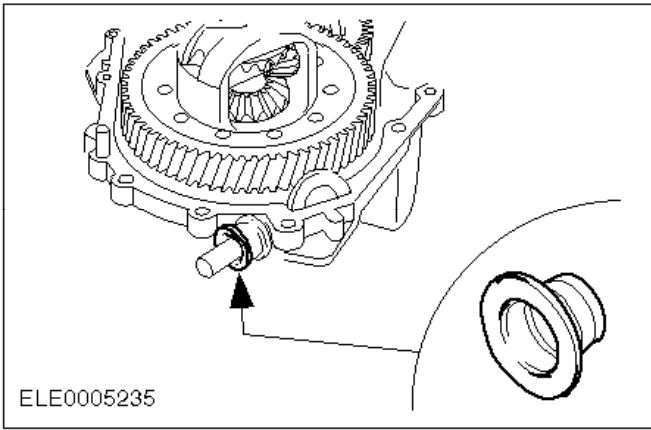

105. Remove the assembly sleeve, fit the dust cover.

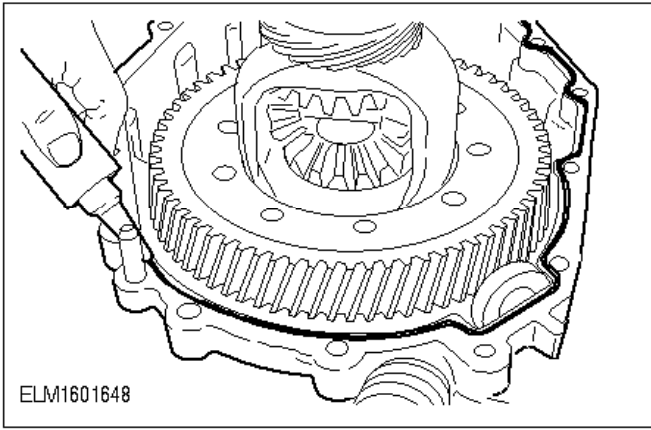

Note:

The mating face must be dry. Apply sealer (WSK-M2G348-A5) evenly on the inside of the sealing surface. (The sealant bead should have a constant diameter of about 2 mm.)

106. Apply sealer to the mating face.

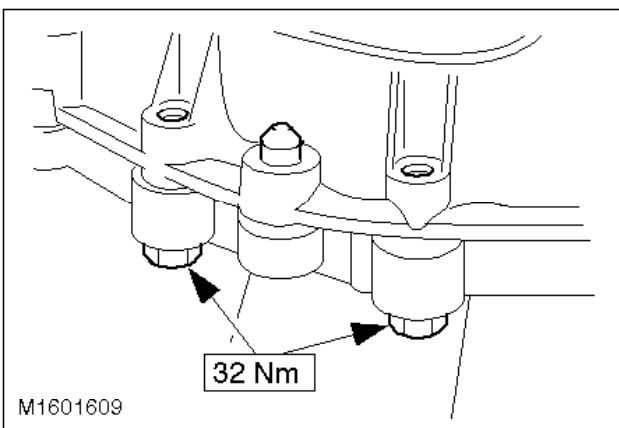

107. Fit the transmission housing sections on the clutch side.

Note:

The transmission housing must not, under any circumstances, be turned when tightening the bolts.

- Tighten the 16 flange bolts within 15 minutes, working diagonally.

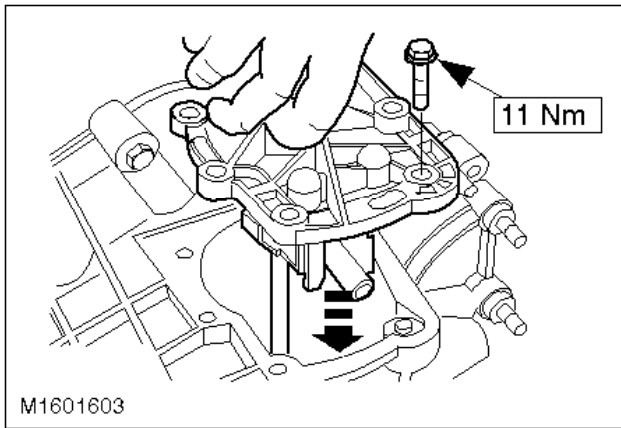

Note:

Put the gearshift mechanism in neutral.

108. Fit the selector mechanism.

- Apply sealer evenly to the outer side of the mating face.
- Fit the selector mechanism and tighten.

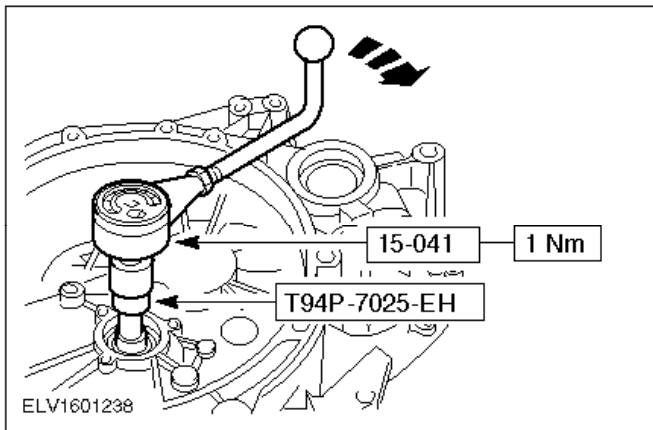

Note:

If the turning torque is too high, all the measurements must be repeated (including the measurement to determine the required shim thickness).

109. Measure the turning torque.

- Engage 4th gear.
- Measure the turning torque.

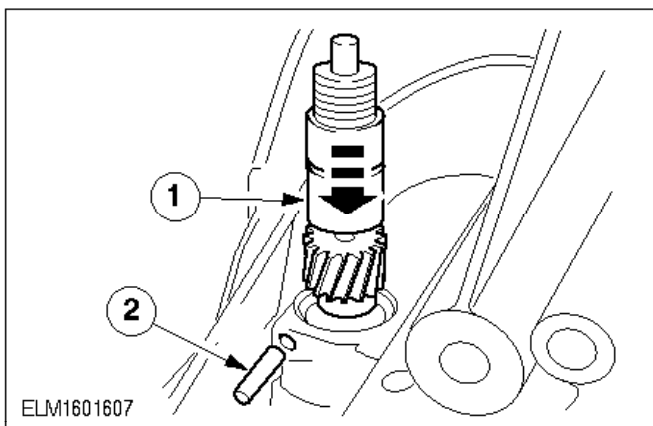

110. Fit the speedometer worm drive.

- 1 Install the drive pinion.
- 2 Drive in the notched pin using a hammer.

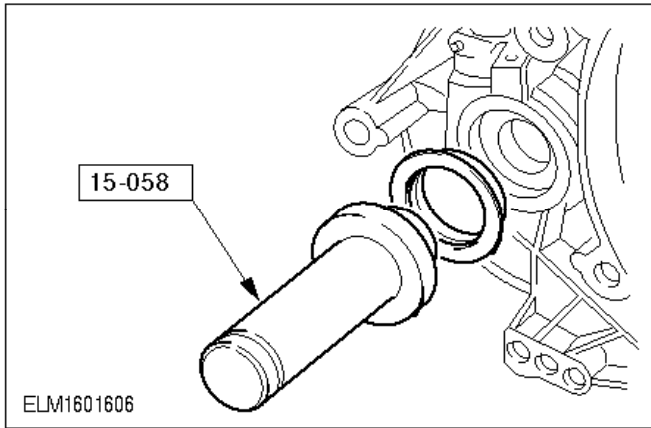

Fit the differential oil seal.

111. Fit the differential oil seals.

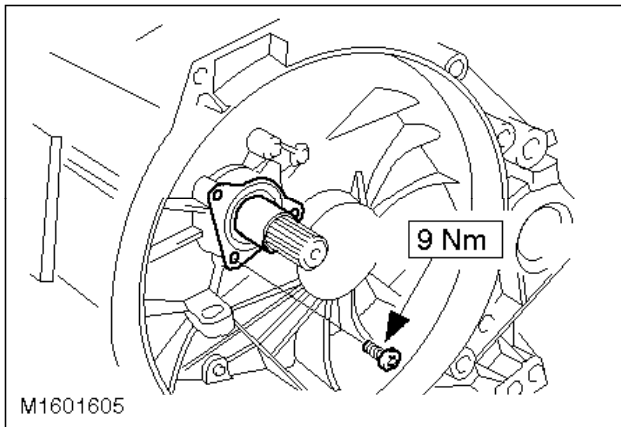

112. Install the guide sleeve.

Fit the guide sleeve with a new O-ring and apply sealer (WSK-U26348-A5).

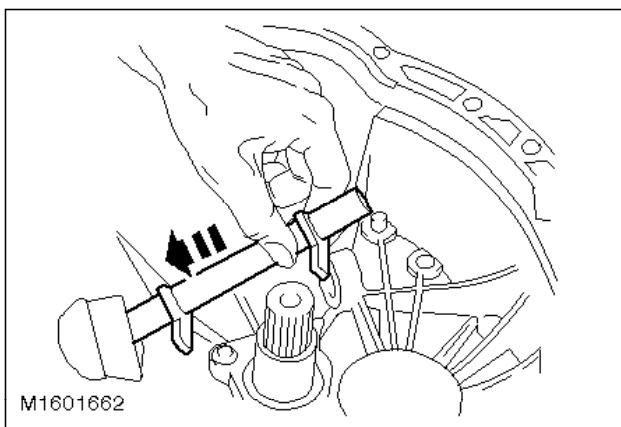

113. Install the release shaft.

Coat the bearing points on the release shaft with high-melting point grease.

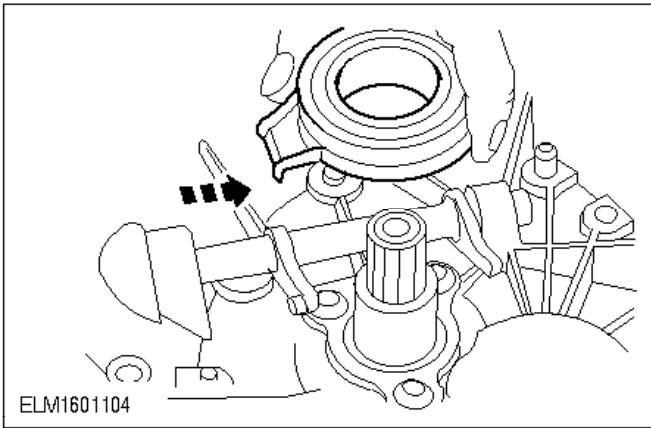

- 114. Fit the thrust bearing.

Coat the guide sleeve and clutch teeth thinly with high-melting point grease.

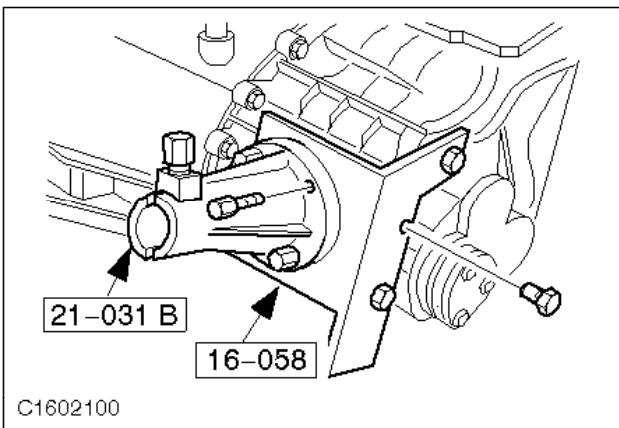

- 115. Remove the special tools.

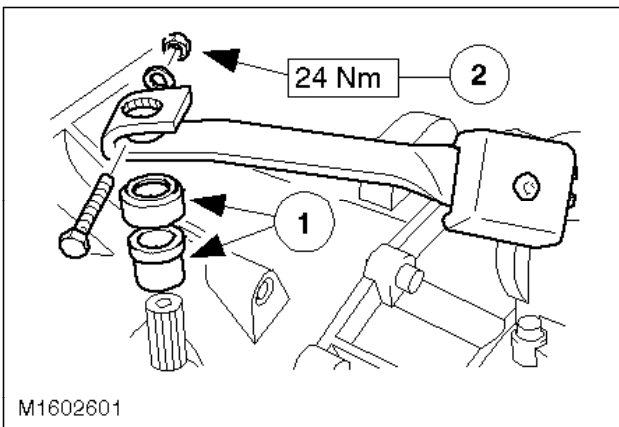

- 116. Fit the clutch release lever.

- 1 Fit the bearing bush and the protective cap.
 - 2 Fit the clutch release lever and tighten the bolts.
-