



## 6DCT450/470

### INDEX

<b>6DCT450</b> International vehicle application per Transtec's Original Guide to Automatic Transmissions by Vehicle Global edition .....	3
6DCT 450 Introduction.....	4
The Getrag Portfolio.....	5
Line Pressure Tap.....	7
Drain Plugs.....	8
Fill Plug, Check Plug and Fluid Information.....	9
Transmission Range Sensor.....	10
Computer Modes and Strategies.....	12
Powerflow.....	14
Dog Clutch.....	20
Clutch Housing Removal.....	21
Valve Body Removal.....	29
Case Passage Identification.....	30
Fork Identification.....	31
Solenoid Identification and Function.....	33
Valve Body.....	35
TCM/Inputs/Wire Diagram.....	41
<i>6DCT470 Significant differences compared to the 6DCT450</i>	
<b>6DCT470</b> International vehicle application per Transtec's Original Guide to Automatic Transmissions by Vehicle Global edition .....	45
Transmission Range Sensor.....	46
Wiring Diagram/TCM Terminal ID.....	47
Shaft to Case Orientation/Gear and Shaft Identification.....	49
Clutch Identification.....	51
Valve Body Removal.....	52
Case Passage Identification.....	53
Solenoid Identification and Function.....	54
Valve Body.....	56
TCM Topography/Fork Assignments.....	62
Diagnostic Trouble Codes.....	63

#### 6DCT450

6DCT450 Valve body Mapping text.....	66
6DCT450 Valve body Mapping schematic....	74
6DCT450 Park/Neutral schematic.....	75
6DCT450 Reverse schematic.....	76
6DCT450 1st Gear schematic.....	77
6DCT450 2nd Gear schematic.....	78
6DCT450 3rd Gear schematic.....	79
6DCT450 4th Gear schematic.....	80
6DCT450 5th Gear schematic.....	81
6DCT450 6th Gear schematic.....	82

#### Hydraulic Schematics

#### 6DCT470

6DCT470 Valve body Mapping text.....	83
6DCT470 Valve body Mapping schematic....	91
6DCT470 Park/Neutral schematic.....	92
6DCT470 Reverse schematic.....	93
6DCT470 1st Gear schematic.....	94
6DCT470 2nd Gear schematic.....	95
6DCT470 3rd Gear schematic.....	96
6DCT470 4th Gear schematic.....	97
6DCT470 5th Gear schematic.....	98
6DCT470 6th Gear schematic.....	99



## *Introduction*

The DCT450 (Ford/Volvo) and the DCT470 (Mitsubishi) are a double wet clutch 6 speed automatically controlled manual shift gearbox by Getrag. This transmission is referred to as the Powershift transmission in both Ford and Volvo while Mitsubishi calls it their Twin-Clutch Sportronic Shift Transmission (TC-SST). Technical data from Ford may refer to this transmission as DPS6, Volvo; MPS6 and Mitsubishi; W6DGA or SPS6. These two transmissions may look very similar externally but there are many significant differences. This manual provides the major differences between these two very similar gearboxes by Getrag with complete valvebody breakdowns and hydraulics. One such notable difference is that the DCT450 uses a double input shaft with the inner shaft providing power to the odd gears and the outer shaft for the even gears. Mitsubishi's DCT470 is just the opposite. The Inner input shaft is used for the even gears and the outer for the odd.

*Many thanks to Automatic Choice in the Netherlands for providing these transmissions and for ALTO Products for shipping them to our research center in Miami Florida.*

No part of any ATSG publication may be reproduced, stored in any retrieval system or transmitted in any form or by any means, including but not limited to electronic, mechanical, photocopying, recording or otherwise, without *written* permission of Automatic Transmission Service Group. This includes all text illustrations, tables and charts.

*The information and part numbers contained in this booklet have been carefully compiled from industry sources known for their reliability, but ATSG does not guarantee its accuracy.*

Copyright © ATSG 2012

**WAYNE COLONNA**  
PRESIDENT

**PETER LUBAN**  
TECHNICAL SUPERVISOR

**GERALD CAMPBELL**  
TECHNICAL CONSULTANT

**CLAY WICKHAM**  
TECHNICAL CONSULTANT

**GREG CATANZARO**  
TECHNICAL CONSULTANT

**JON GLATSTEIN**  
TECHNICAL CONSULTANT

**JIM DIAL**  
SENIOR CONSULTANT

**DALE ENGLAND**  
TECHNICAL CONSULTANT

**ED KRUSE**  
TECHNICAL CONSULTANT

**GREGORY LIPNICK**  
TECHNICAL CONSULTANT

**DAVID CHALKER**  
TECHNICAL CONSULTANT

**JERRY GOTT**  
TECHNICAL CONSULTANT

***AUTOMATIC TRANSMISSION SERVICE GROUP***

**18635 SW 107TH AVENUE  
CUTLER BAY, FLORIDA 33157  
(305) 670-4161**



## *Technical Service Information*

### *Powershift 6DCT450 Getrag Transmission*

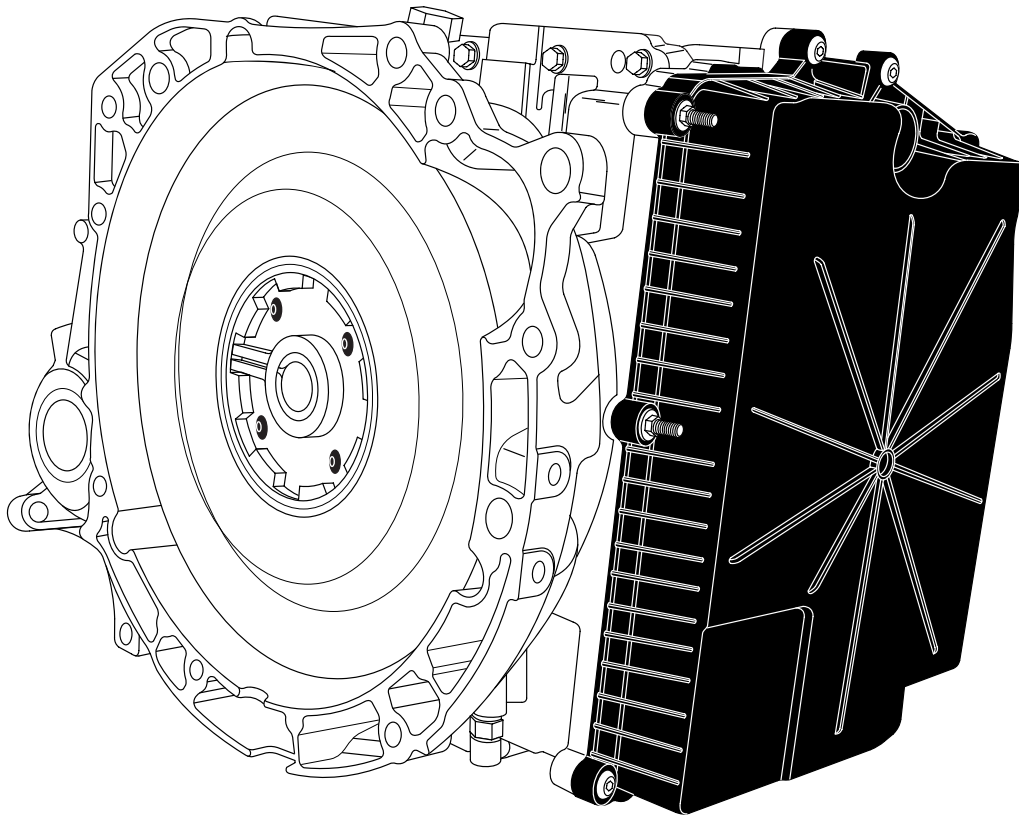

*Ford - DPS6 Transmission  
Ford Focus (2008–present)  
Ford C-MAX (2008–present)  
Ford Fiesta (2010–present)  
Ford S-MAX (2010–present)  
Ford Galaxy (2010–present)  
Ford Kuga (2010–present)  
Ford Mondeo (2010–present)*

*Volvo - MPS6 Transmission  
Volvo C30 (2008–present)  
Volvo S40 (2008–present)  
Volvo V50 (2008–present)  
Volvo C70 (2009–present)  
Volvo V70 (2009–present)  
Volvo S80 (2009–present)  
Volvo S60 (2010–present)  
Volvo V60 (2010–present)*

**AUTOMATIC TRANSMISSION SERVICE GROUP  
18635 S.W. 107 AVENUE  
CUTLER BAY, FLORIDA 33157  
(305) 670-4161**

[www.atsg.biz](http://www.atsg.biz)

[www.atsg.com](http://www.atsg.com)

*Copyright © ATSG 2012*

## Technical Service Information

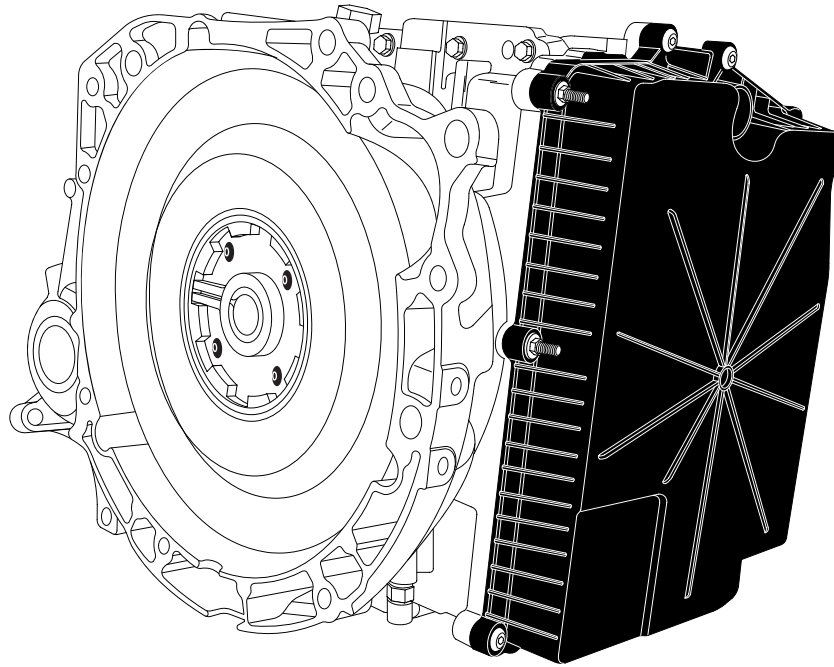

The 6DCT450 is a 6-speed electronically controlled transmission otherwise referred to as a Powershift transmission. It may also be referred to as a DPS6 with Ford or an MPS6 with Volvo. It has the same function as an automatic transmission but is more similar to a manual transmission. The design of the transmission includes three shafts and two clutches (wet double clutch) but no clutch pedal. Electronics and hydraulics control the clutches just like in a conventional automatic transmission. The transmission features a split (divided) input shaft with a clutch for each shaft that work independently of each other. Clutch 1 transmits the power to the input shaft for the Odd gears 1, 3, 5, and R while. Clutch 2 transmits the power to the input shaft for the even gears 2, 4, and 6.

The transmission has 4 gearshift forks which are controlled by the Transmission control module (TCM) via solenoids. Electronics and hydraulics also control the clutches via the Transmission control module (TCM) or via manual shifting in the same way as in a conventional automatic transmission. In case of manual shifting, the driver handles gearshifting.

The gears are pre-selected, that is, one clutch makes sure that the current gear ends up in the correct position while simultaneously the other clutch prepares the next gear. This set-up means that the power transfer from the engine to the transmission is not interrupted when shifting. This also allows shifting to take place while under load, thus a permanent power transfer can be maintained, which is the meaning of Powershift.

The gearshift lever is of the same type as for conventional automatic transmissions and has positions P, R, N, D, and M.

The transmission fluid is a high-quality synthetic oil which is unique for this type of transmission.

The transmission is intended to be a part of a transverse drivetrain with front-wheel drive.

The transmission weighs 91 kg with oil and has a maximum torque of 450 Nm.





# Technical Service Information

## The Getrag Portfolio

<http://www.getrag.com>  
(Select Powershift)

### 1. Transverse design

- 6DCT250 with dry clutch – Ford & Renault applications
- 6DCT450 with wet clutch – Ford (**PowerShift**) & Volvo (**MPS6**) applications
- 6DCT470 with wet clutch – Mitsubishi & PSA (**Twin Clutch SST - Sportronic Shift Transmission**)
- 6DCT451 with wet clutch – under development, not in serial production

### 2. What order do these transmissions appear?

All the transmissions with wet clutches were launched near simultaneously in the beginning of 2008.  
6DCT250 with dry clutch was launched beginning 2010.

### 3. Longitudinal design

7DCL750 with wet clutch – Ferrari & AMG applications beginning 2008

### 4. Inline design

7DCI700 with wet clutch – BMW applications launched mid 2008

### 5. Torque capacities - Newton meter to foot pound

- 7DCL750 - Longitudinal transaxle for front & mid- engine
- 7DCI600 - Inline for RWD
- 6DCT470 - Transverse for FWD-AWD
- 6DCT450 - Transverse for FWD-AWD
- 6DCT250 - Transverse for FWD

Nm (Newton meter) to lb/ft (pound foot) conversion-ratio .7375622

- 750 = 553.17
- 600 = 442.54
- 470 = 346.65
- 450 = 331.90
- 250 = 184.39

### 6. Clutch Types based on torque capacity

There are two primary types of clutches utilized in dual-clutch transmissions: Two sets of wet multi-plate clutches or two sets of dry single-plate clutches. The wet clutch arrangement is primarily used in vehicles with high torque engines whereas the dry clutch arrangement is used in vehicles with lower torque output. Although the dry clutch system is limited in torque capacity, energy to produce oil pressure is not used allowing this arrangement to offer increased fuel efficiency.

## The Getrag Portfolio (continued)

### 7. Clutch Variations - wet, dry, single and multi-plate configurations.

1. Concentric - The dual clutch originally was a 2 plate concentric design where both plates share the same plane from a perpendicular viewpoint. This may also be referred to as being Nested.
2. Parallel - The parallel configuration is a side-by-side set up when viewed perpendicular. The 6DCT450 in Ford and Volvo vehicles utilizes a wet parallel multi-clutch set as seen in figure 1.

### The 6DCT450

The 6DCT450 called the Powershift in Ford and the MPS6 in Volvo applications is a 6 speed dual wet parallel multi-clutch gear box. This gear box contains two input shafts (*one inside another*), two outputs shafts, a reverse idler gear and differential (see figure 7).

Input shaft 1 (Inner Shaft) drives 1st, 3rd, 5th and Reverse.

Input shaft 2 (Outer Shaft) drives 2nd, 4th and 6th.

Output shaft 1 synchronizes 1st, 2nd, 3rd and 4th.

Output shaft 2 synchronizes 5th, 6th and Reverse.

For powerflow operation refer to figures 8-11.

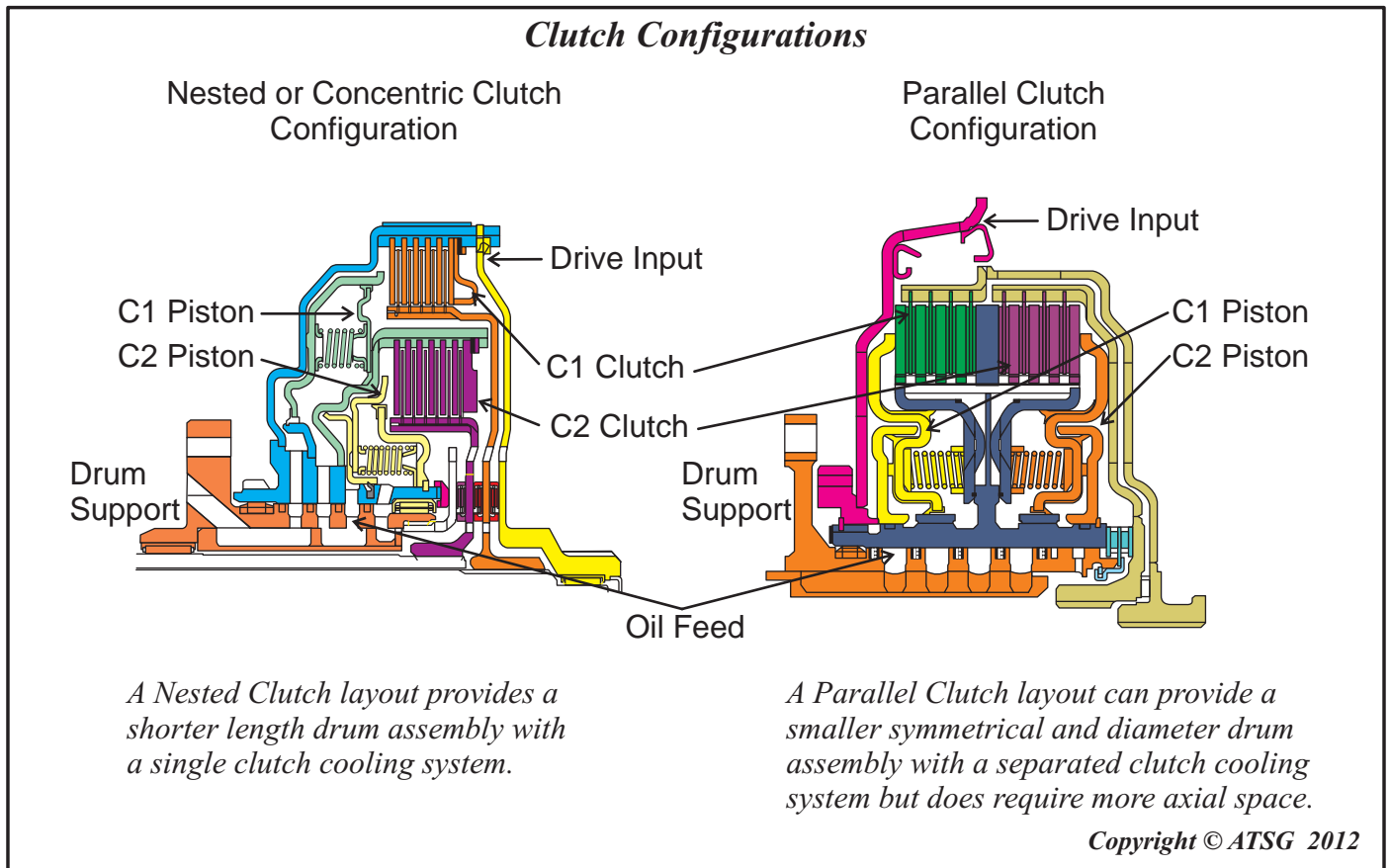
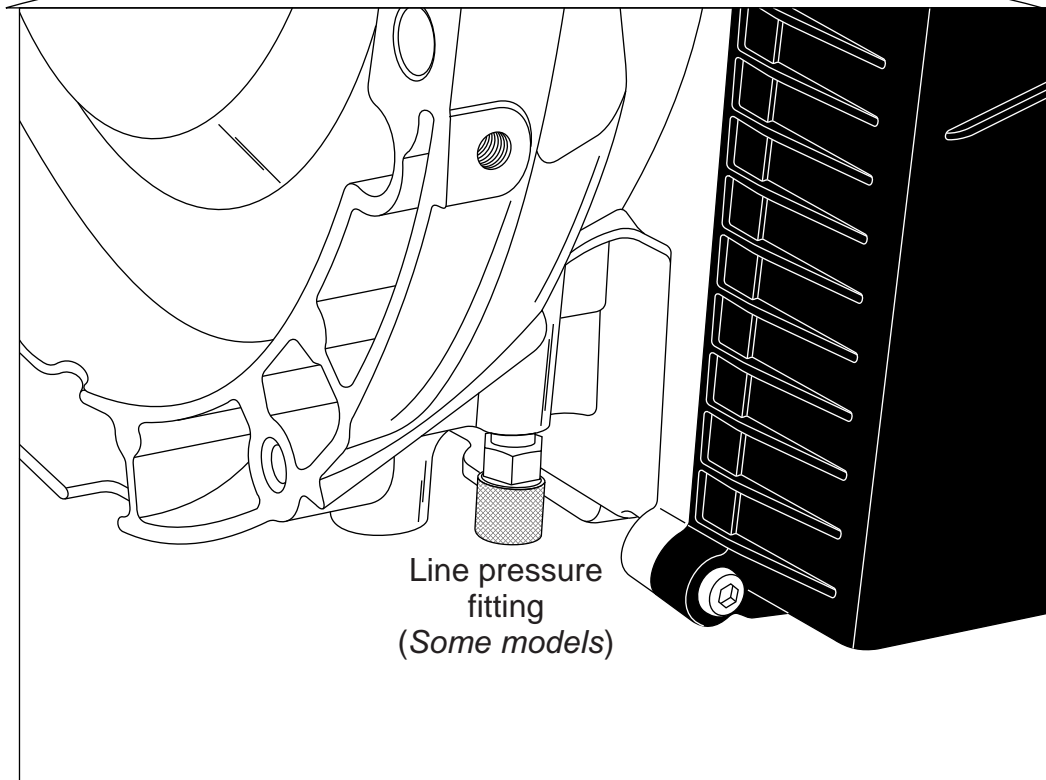
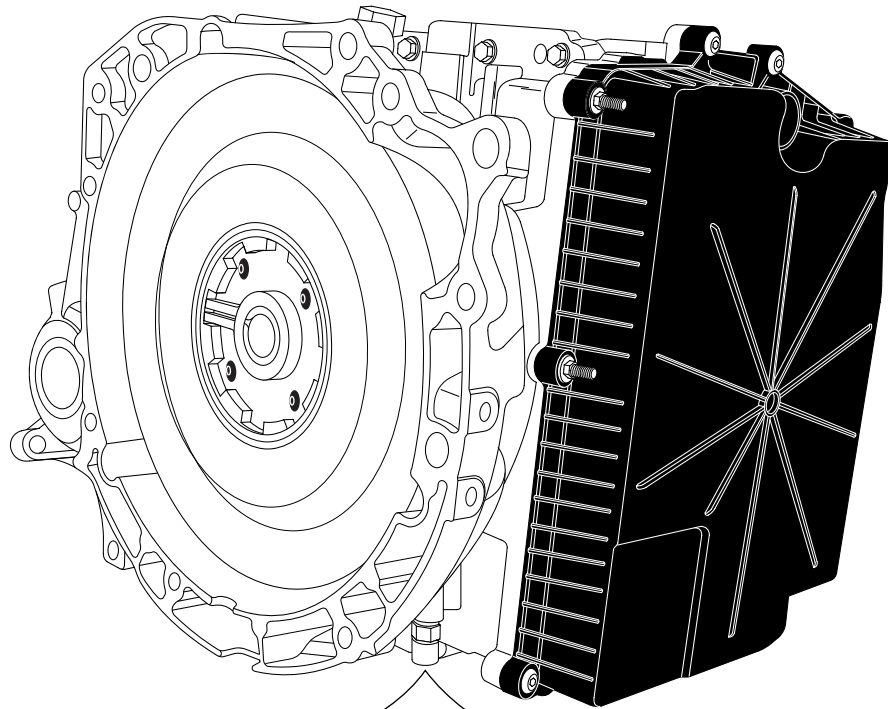

Figure 1



# Technical Service Information

## MAIN LINE PRESSURE FITTING TEST PORT



Line pressure fitting  
(Some models)

Copyright © ATSG 2012

Figure 2  
Automatic Transmission Service Group



# Technical Service Information

## DRAIN PLUGS AND SHIFT RAIL DETENTS

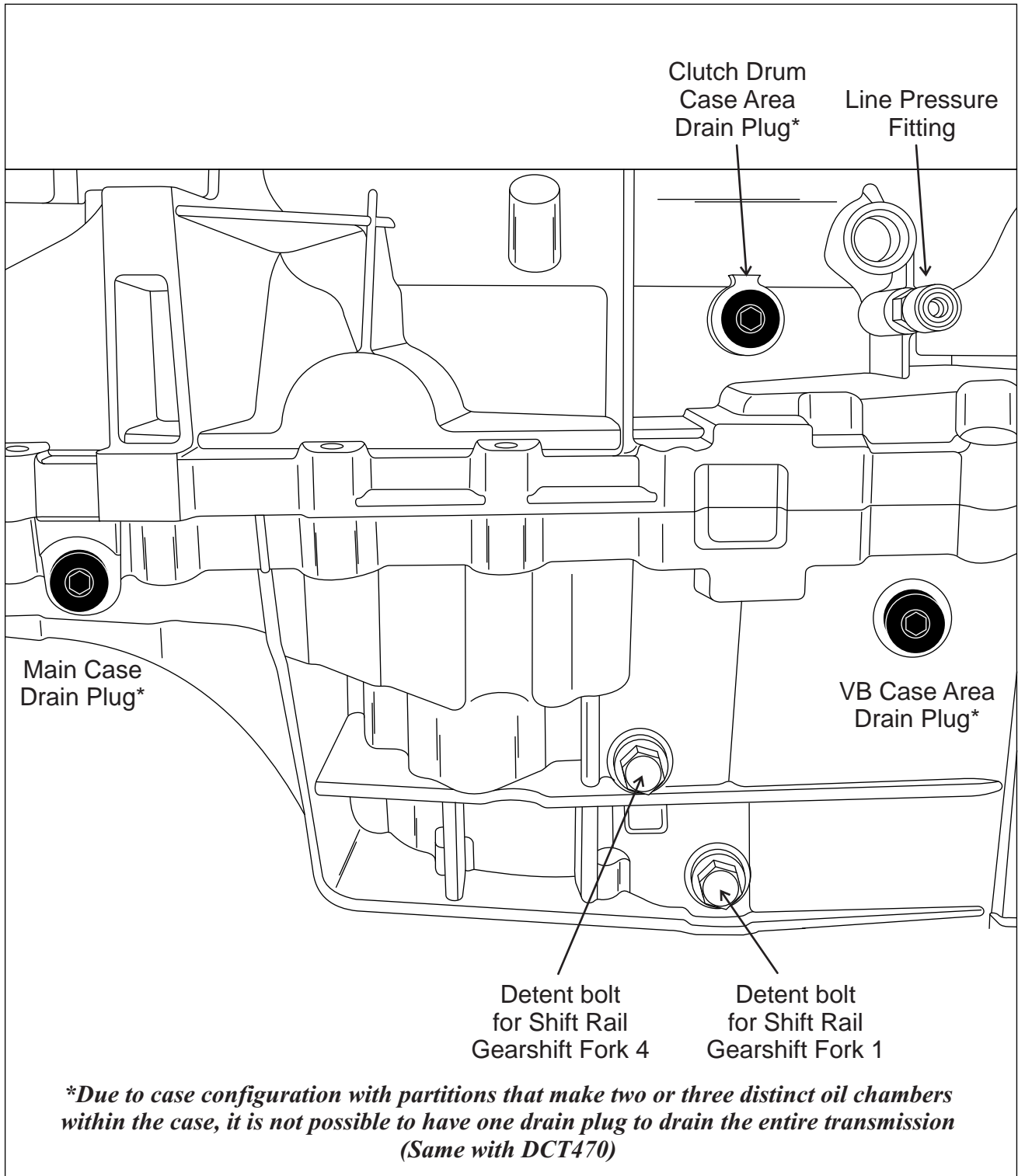

Copyright © ATSG 2012

Figure 3



# Technical Service Information

## CHECK AND FILL PLUGS

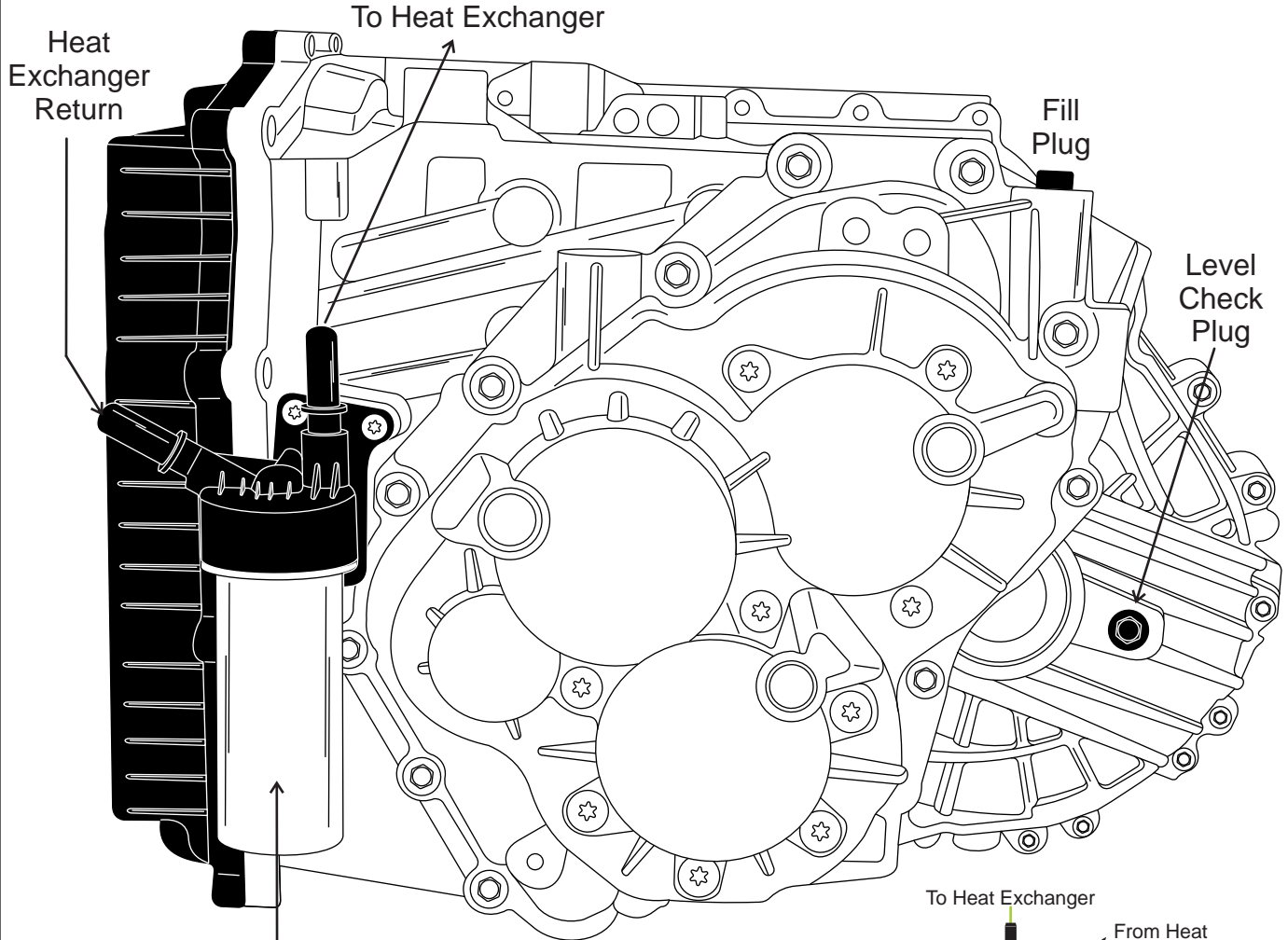

External Oil Filter  
(Filters lube fluid and is part of the cooler bypass strategy)

**Transmission Fluid Type: BOT 341**

Ford part number: XT-11-QDC

Volvo part number: 1161838

Mitsubishi part number: MZ320065

Mitsubishi calls this Dia Queen SSTF-I

Approximately \$28.00 for 1 liter

Full fill - 7.5 liters (8 qt)(includes cooler)

Drain fill - 5.5 liters (6 qt)

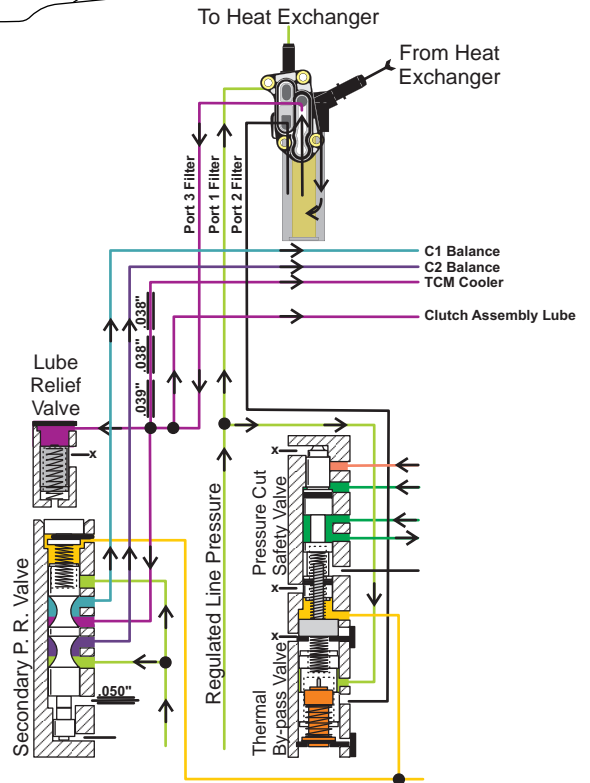

Copyright © ATSG 2012

Figure 4





## Technical Service Information

### TRANSMISSION RANGE SENSOR

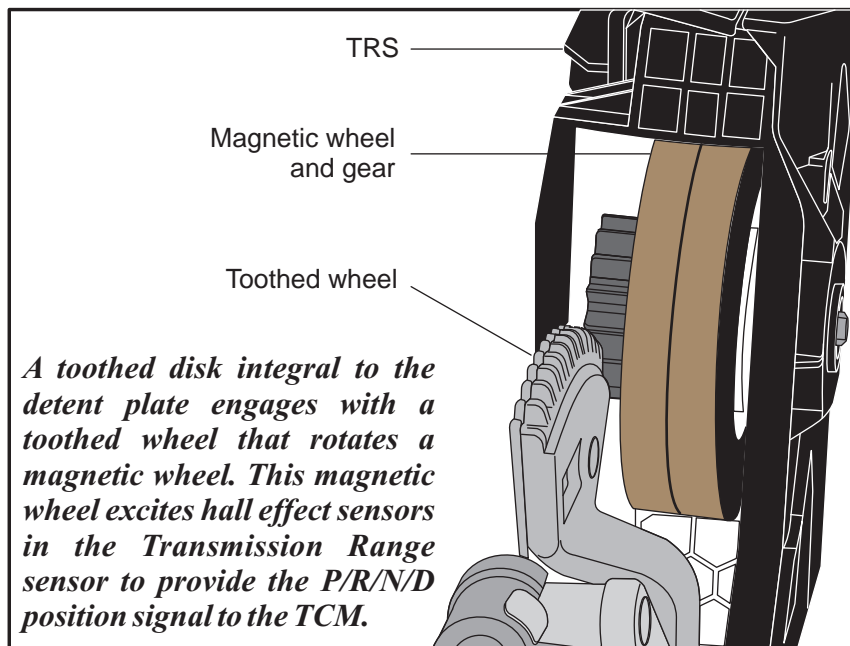
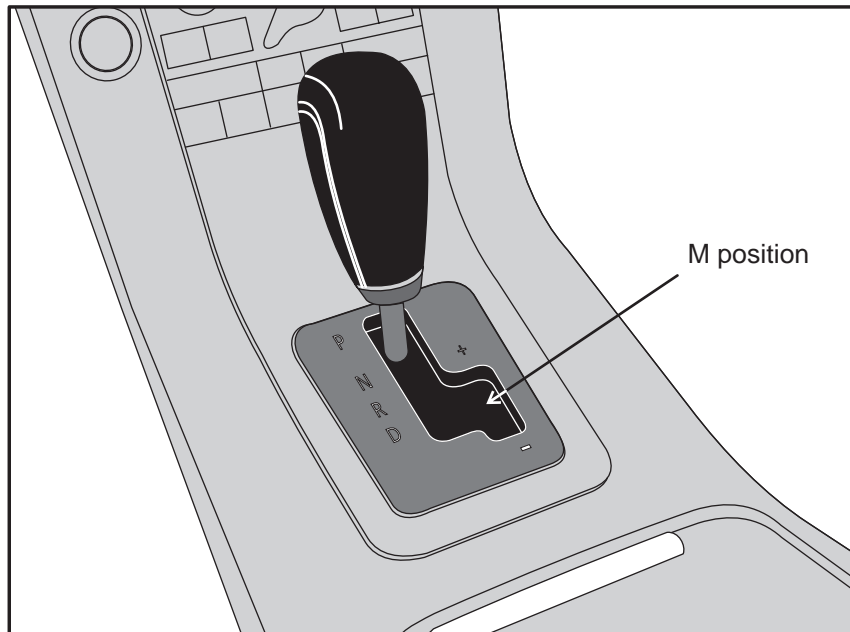

The gear selector assembly positioned in the center console is mechanically connected to the transmission by a cable which is used to engage and disengage the Park gear. It does not move a manual valve in the valve body for there is not a manual valve to move. The shaft inside the transmission which the gear selector lever rotates to engage and disengage park has a detent plate with a toothed disk that rotates a range sensor integral to the TCM. This provides a direct P/R/N/D signal into the TCM.

In addition to the P/R/N/D position signals, the gear selector assembly with Geartronic has a position for manual shifting (M). This signal is generated in the gear selector assembly and is sent to the TCM over the CAN BUS network. The manual gear positions can be selected at any time on the move. For downshifting, the gear selector shall be moved to minus (-). For upshifting, the gear selector shall be moved to plus (+). At start, 3rd gear is the highest possible gear. The engine can only be started in position P or N.

Copyright © ATSG 2012

Figure 5



## Technical Service Information

### TRANSMISSION RANGE SENSOR

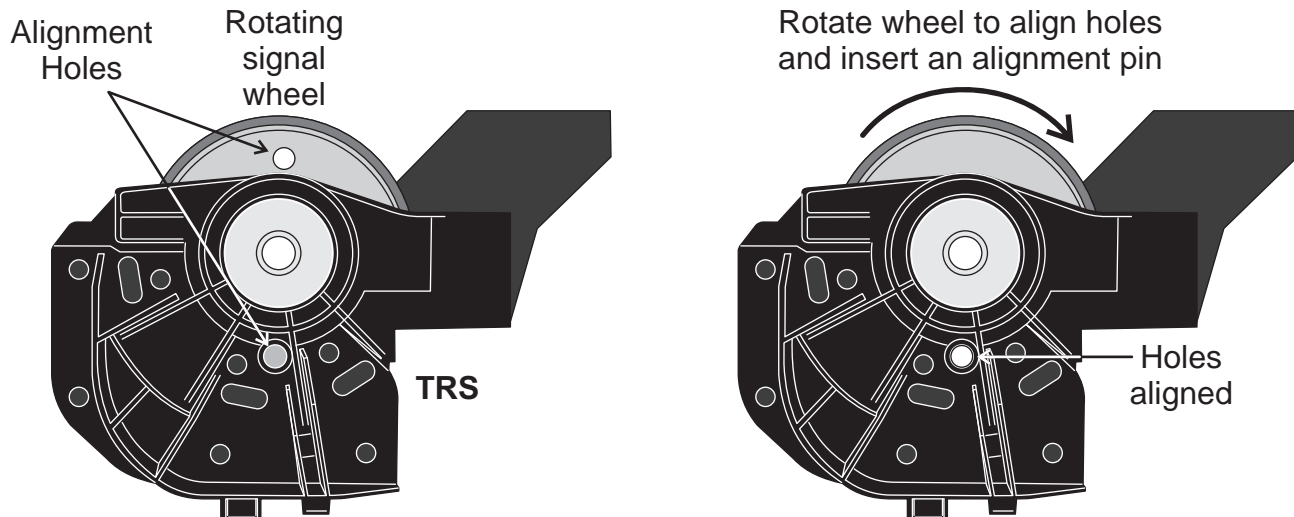
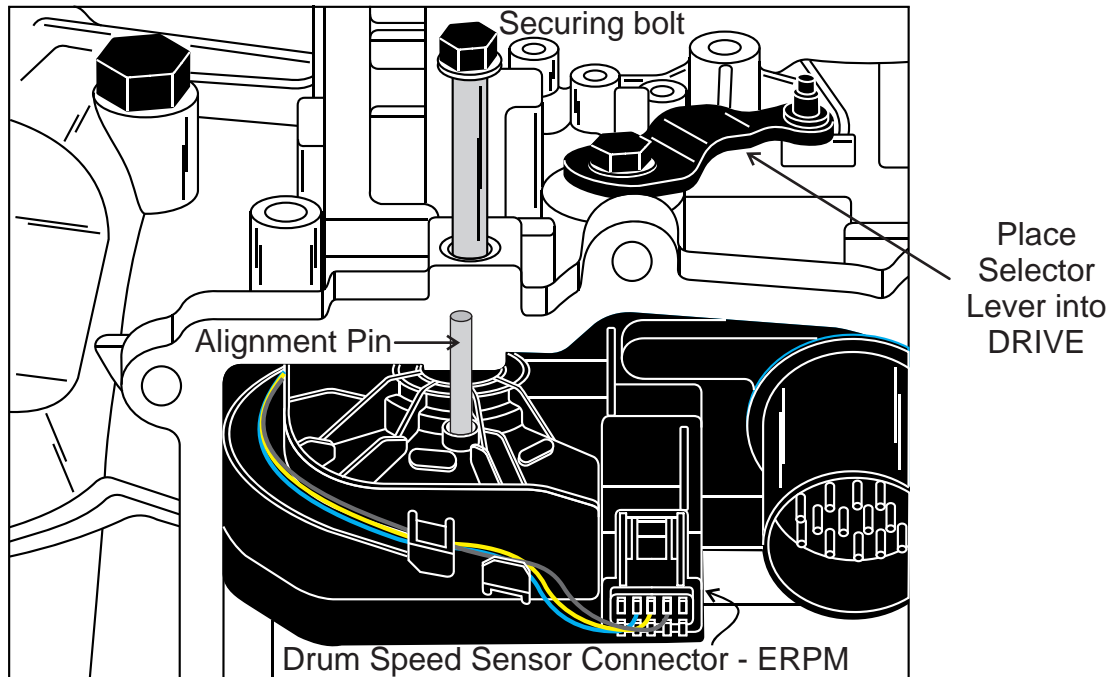

**TRS:** This transmission does not have a manual valve. The transmission range sensor (TRS) is directly connected to the TCM providing the signal it needs to know if the selector lever is placed into Park, Reverse, Neutral or Drive. This sensor contains a wheel with magnets strategically located around approximately half the wheel to excite hall effect sensors with which its position can be determined. This makes aligning the sensor critical when you install the Mechatronic unit into the transmission. This is done by locating an alignment hole in the rotating wheel which then needs to be aligned with the hole in the housing. A .120" alignment pin can then be inserted through the housing hole into the rotating wheel hole to hold this wheel in proper position as you install the assembly into the case.

**Caution: IMPORTANT:** *The signal wheel is rotated by a gear which is engaged with a rotating gear on the manual arm shaft. Witness marks on the gear that rotates the signal wheel suggest that the manual lever needs to be in the DRIVE position when aligning the TRS with the .120" pin through the housing into the rotating wheel. When you disassemble one of these for the first time, take notice to be sure this is correct as we were unable to locate manufacturer information documenting this process.*

Copyright © ATSG 2012

# Technical Service Information

## GEAR SHIFT PROGRAMS

### Normal program

When driving with normal throttle application, the TCM uses a pre-set shifting program, optimized to shift for economic driving. The shifting program adapts automatically to different driving conditions, e.g., driving on a grade with a trailer or driving at high altitude. Also, the transmission's oil pressure is adapted to give smooth engagement of gears.

### Adaptation

The TCM monitors every shift to give consequent and smooth shifts under all driving conditions. This is done by the TCM either lowering or increasing the hydraulic system pressure that is used during actual shifting. The changed pressure levels are stored in the control module's memory when the vehicle is turned off, and are retrieved when the vehicle is started. This gives the transmission better shifting comfort and life. Before the components become too worn, an adaptation can also be used to compensate for wear of components in the transmission.

### *Powershift uses 4 different adaptations:*

- Gear adaptation. Condition, gear engaged and engine's static torque within  $\pm 30$  Nm.
- Adaptation of clutch application pressure. Condition, no gear engaged, Even or Odd, as well as the clutch not in a torque transfer mode (torque control mode).
- Adaptation of clutch preparation pressure. Condition, clutch pressure not above application pressure.
- Adaptation of clutch torque. Condition, temperature of hydraulic oil (value from sensor in oil sump) and clutch surface within specified interval, clutch in torque control mode and clutch torque within specified interval.

### Driving uphill

The TCM can change the gearshift pattern slightly when driving uphill. This is to avoid close gearshifts.

### Neutral control

This is a function that is activated when the driver stops and the vehicle is stationary, e.g., at a red light. The TCM disengages the clutches, which means that the transmission's forward drive is reduced, as well as the engine load.

The function reduces both fuel consumption and vibrations. When the driver releases the brake, the clutch torque increases on the clutch for which the gear is engaged, and drive increases. The following conditions must be met in order for the neutral function to activate:

- gear lever in D or R.
- throttle position 0%
- brake pedal pressed down.
- speed 0 km/h.

# Technical Service Information

## GEAR SHIFT PROGRAMS

### Hot mode

When driving for a long time with high load, e.g., slow driving on steep grades or with a trailer, the transmission and clutch work hard, which leads to increasing temperature in the transmission oil and clutch. A function called Hot mode is used to prevent damage to the transmission due to too high temperature in the oil and in the clutch.

The function is controlled by the TCM that, through different steps, tries to prevent the temperature from becoming too high:

- The flow in the transmission increases by increased idle rpm for better cooling. Gearshifts are made harsher to reduce heat generation in the transmission.
- A message is sent to the Driver information module (DIM) to brake to relieve the clutches.
- The clutch starts to oscillate to warn the driver before the clutches open.
- The clutches open.

### Alternative driving programs

There are driving programs that are implemented in the transmission but that only are active on certain variants.

#### Kick-down

When the accelerator pedal is pressed down past a certain point, the Kickdown function is activated. This means that downshifting takes place to get faster acceleration. The pedal position for Kickdown is designated as 110%.

#### Quick step

Quick step makes the gearshifting function sportier when the driver is more aggressive on the pedal. Lower gears are used for better acceleration.

#### Fast Off

Fast Off is used to reduce the number of shifts due to heavy traffic in, e.g., city traffic. The function is activated at fast releases of the accelerator pedal. Even the vehicle's speed, brake pedal, and curve detection affect its function. By keeping a lower gear than normal, unnecessary shifts are avoided. For aborted passing, a lower gear is maintained to be able to take the initiative for future passing.

### Gearshifting with Geartronic

When the gear selector is moved to the Geartronic-position (M), the automatic transmission is still hydraulically in position D. By moving the gear selector up (+) the Gear selector module (GSM) sends a signal to Transmission control module (TCM) to upshift.

If the gear selector is moved down (-) a signal is sent to the TCM to downshift. The Driver information module (DIM), when gear selector is in manual shifting mode, switches symbols in the DIM from D to current gear position, e.g., 3. A signal is also sent to Gear selector module (GSM) to light both LEDs for + and -, to and turn off the other LEDs. The TCM decides if shifting can be performed and the DIM will indicate the current gear. If shifting is allowed, the different solenoids are activated according to the specific pattern for each gear.

# Technical Service Information

## GEAR SHIFT PROGRAMS AND POWERFLOW

However, in certain situations the TCM will take over responsibility for determining shifting. The following applies:

- If the maximum engine rpm should be exceeded when downshifting, then the TCM will prevent a downshift.
- Start from a standstill can take place in 1st or 2nd gear in Geartronic-mode. 3rd gear can be selected at speeds above 25 km/h, 4th gear at speeds above 40 km/h, 5th gear at speeds above 50 km/h, as well as 6th gear at speeds above 60 km/h.
- Change between automatic and manual can be performed in both directions under all driving conditions.
- Automatic upshifting takes place at maximum rpm and at kickdown.
- Automatic downshifts take place in all gears when driving slower than a certain speed and at kickdown. Example: 2nd gear is selected. Automatic downshifting takes place from 2nd gear to 1st at 2 km/h if the speed before that has been above 20 km/h. Otherwise 2nd gear remains. E.g., situations may arise where 3rd gear still is engaged even when the vehicle has been stopped.
- After automatic downshifting, manual upshifting is required except when kickdown is used and the pedal position remains in kickdown position.
- Allowed rpms for manual downshifts match those for kickdown upshifts, that is, maximum engine rpm.
- If the transmission's temperature should become too high, the TCM assumes the decisions about gearshifting.

## POWERFLOW

As mentioned previously this MPS6 transmission has 2 separate input shafts one inside another along with a clutch for each shaft. Clutch 1 transmits the power to input shaft 1 for the Odd gears 1, 3, 5, and R while Clutch 2 transmits the power to input shaft 2 for the even gears 2, 4, and 6. The TCM adapts shifting so that the correct gear is always selected with consideration of driving manner, engine load, driver's wishes, speed, etc. This style transmission gives better fuel economy compared from conventional automatic transmissions with a torque converter. The TCM receives information on desired gear position and desired driving manner (driving program) from the driver. The TCM then adapts the gear ratio to the individual driving manner and current load. Gear ratio is selected automatically by the Transmission control module (TCM) or via manual shifting. In case of manual shifting, the driver handles gearshifting. The TCM receives information on the following to enable exact determination of shifting points based on selected driving program:

1. Gear position sensor
2. Vehicle speed from the BCM via the CAN network
3. Engine RPM,
4. Both shaft speed sensors
5. Engine Torque from the ECM over the CAN network
6. Brake apply signal
7. Accelerator Pedal position
8. Transmission fluid temperature
9. Engine temperature
10. Steering wheel position via the Steering Wheel Module (SWM) over the network to prevent upshifting when cornering.





# Technical Service Information

## 6DCT450 INTERNAL GEARBOX COMPONENTS

### Synchronization

1st, 2nd, 3rd and 4th gears utilize double brass synchronizing rings while 5th, 6th and back-up gears use a single synchronizing ring.

Each synchronizing assembly consist of an interlock ball, springs and companion flange.

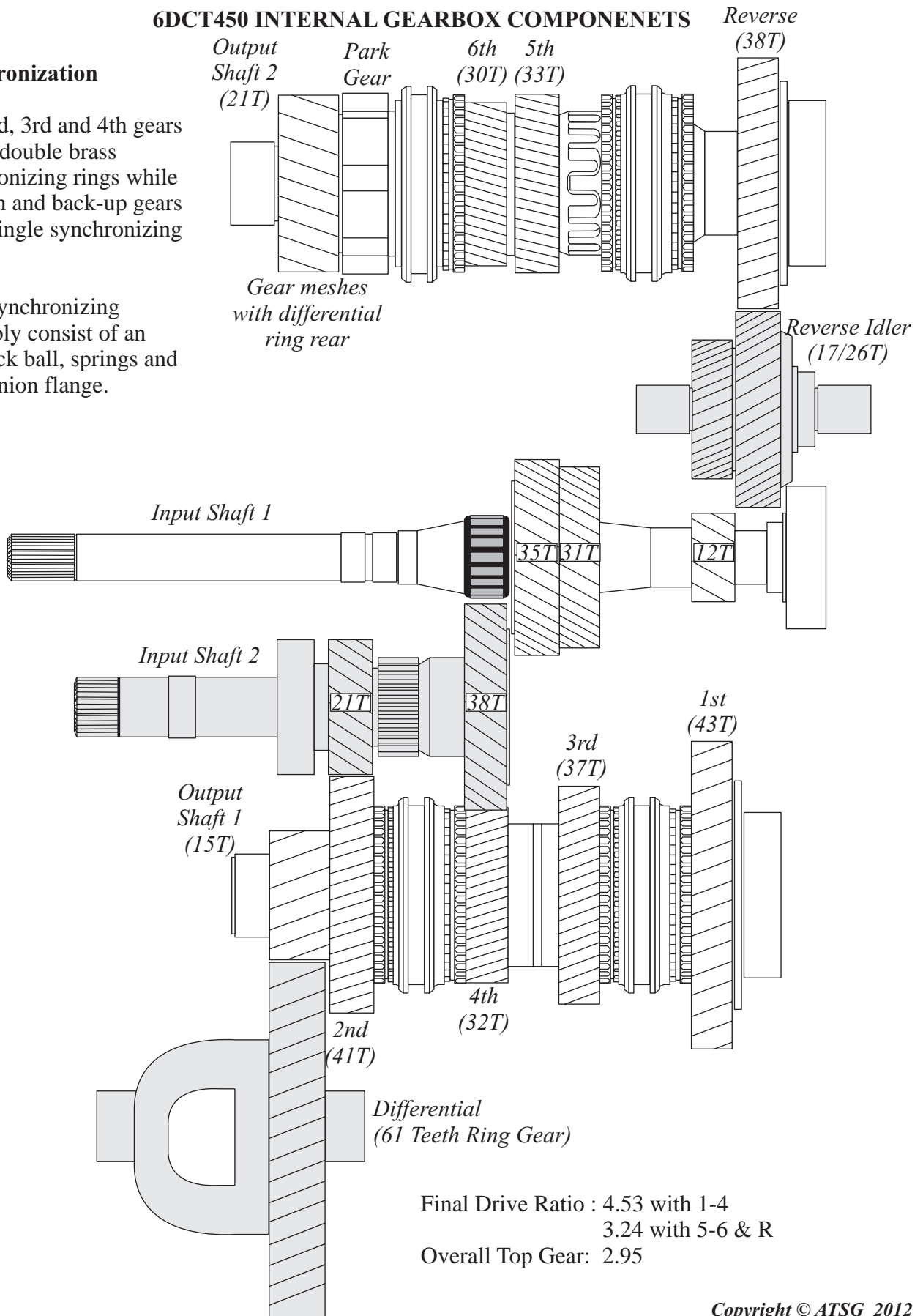

Copyright © ATSG 2012

Figure 7



## Technical Service Information

### 6DCT450 POWERFLOW

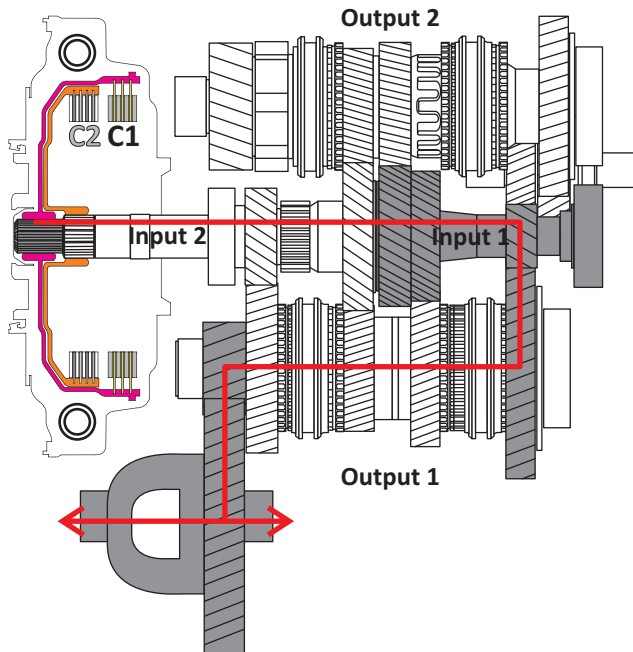

#### 1st Gear:

C1 is on driving Input Shaft 1 (Inner Shaft). Odd gear shift fork 2 engages 1st gear on Output shaft 1 which connects to the differential for a 1st gear ratio of 3.58:1

#### Shift Transition:

Each shift transition is a 7 step process. The 1-2 shift will serve as an example for all shifts:

1. 1st gear fully engaged transmitting full torque while 2nd gear is in a neutral position.
2. 1st transmits full torque.  
2nd gear's control device is pressurized to synchronize and engage 2nd gear.
3. 1st transmits full torque.  
2nd gear is fully engaged. The C2 clutch begins to fill with hydraulic pressure. *It is only during shifting that both clutches work at the same time.*
4. 1st gear simultaneously reduces torque as 2nd gear increases in torque delivery.
5. 1st gear reaches 0 torque delivery when 2nd gear takes over the force.
6. The C1 clutch is completely empty and 1st gear does not transmit any power. 2nd gear slip is 0.
7. 1st gear disengaged. 2nd gear transmits full torque.

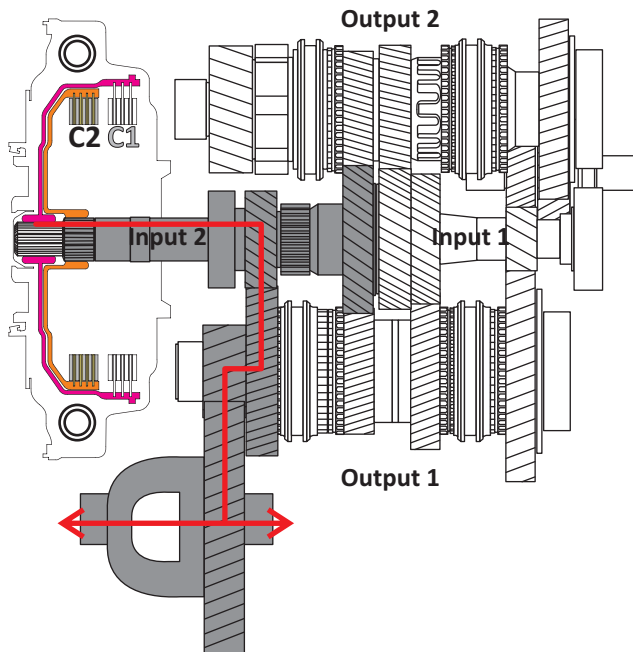

#### 2nd Gear:

C2 is on driving Input Shaft 2 (Outer Shaft). Even gear shift fork 3 engages 2nd gear on Output shaft 1 which connects to the differential for a 2nd gear ratio of 2.05:1

**Note:** All gear ratio specs were provided from a Chrysler Sebring Sedan Specification sheet. The sheet stipulated that the information shown was based on data available at the time of publication September 1st, 2009. Specifications are valid for Europe and may vary in other international markets. Since this printing Chrysler backed out of using the DCT450 (MPS6).

Copyright © ATSG 2012

Figure 8



# Technical Service Information

## 6DCT450 POWERFLOW

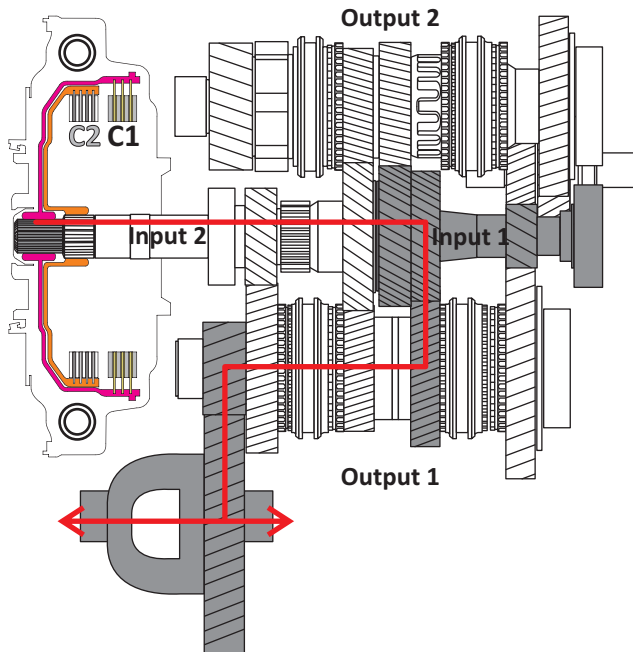

### 3rd Gear:

C1 is on driving Input Shaft 1 (Inner Shaft).  
 Odd gear shift fork 2 engages 3rd gear on  
 Output shaft 1 which connects to the differential  
 for a 3rd gear ratio of 1.32:1

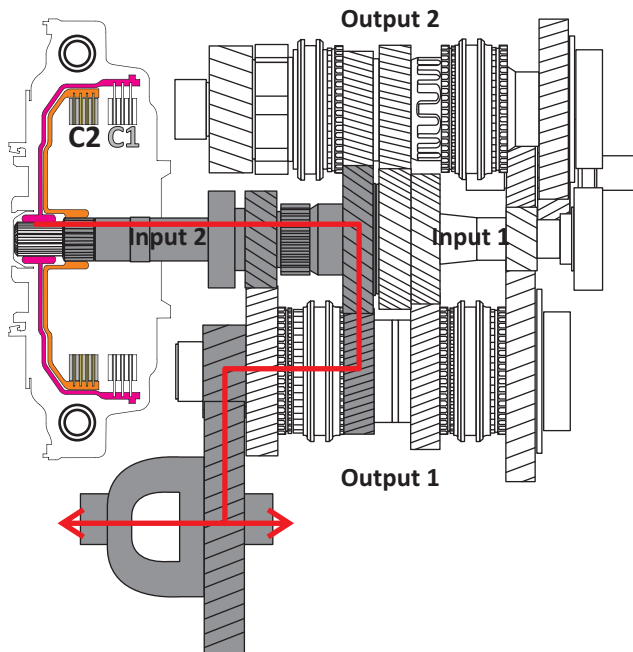

### 4th Gear:

C2 is on driving Input Shaft 2 (Outer Shaft).  
 Even gear shift fork 3 engages 4th gear on  
 Output shaft 1 which connects to the differential  
 for a 4th gear ratio of 1.10:1

Copyright © ATSG 2012

Figure 9



# Technical Service Information

## 6DCT450 POWERFLOW

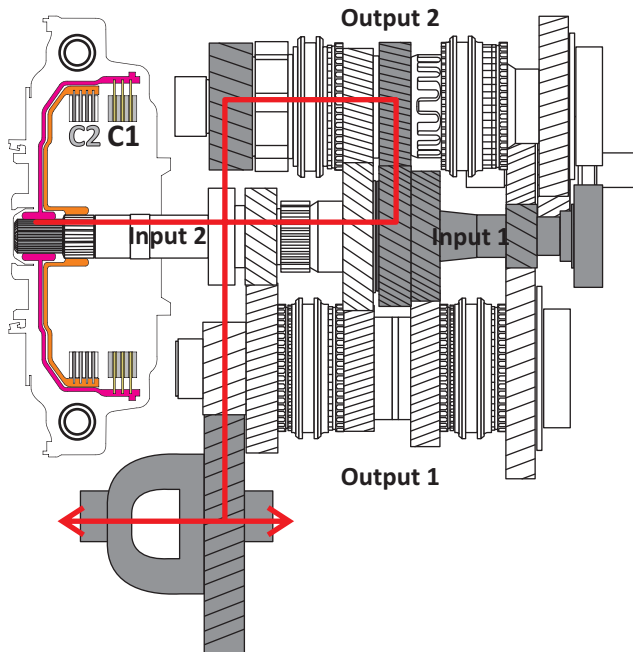

### 5th Gear:

C1 is on driving Input Shaft 1 (Inner Shaft).  
Odd gear shift fork 1 engages 5th gear on  
Output shaft 2 which connects to the differential  
for a 5th gear ratio of 0.97:1

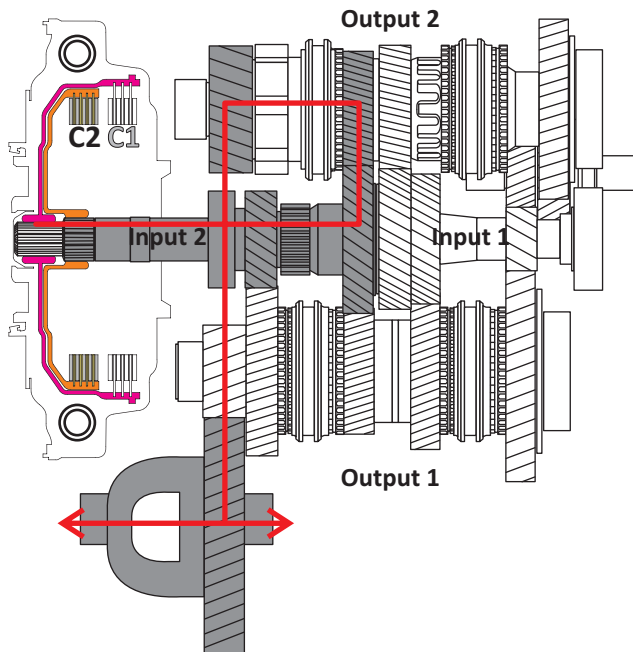

### 6th Gear:

C2 is on driving Input Shaft 2 (Outer Shaft).  
Even gear shift fork 4 engages 6th gear on  
Output shaft 2 which connects to the differential  
for a 6th gear ratio of 0.91:1

Copyright © ATSG 2012

Figure 10



# Technical Service Information

## 6DCT450 POWERFLOW

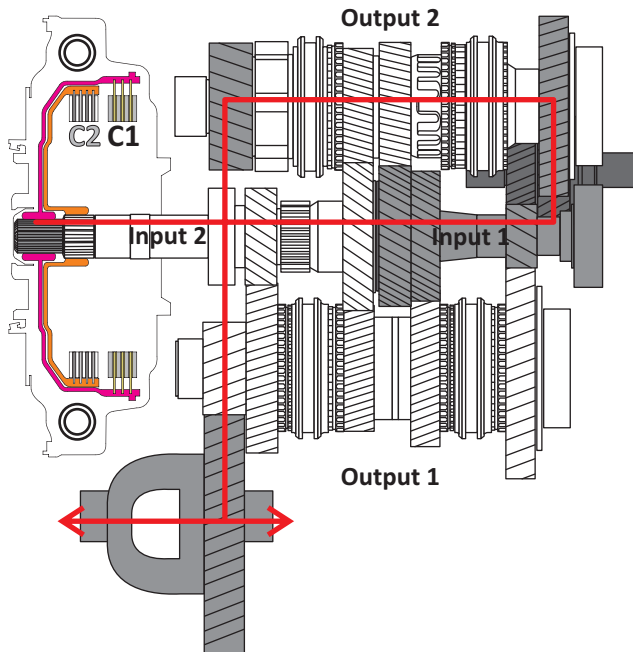

### **Reverse Gear:**

C1 is on driving Input Shaft 1 (Inner Shaft) and Idler. Odd gear shift fork 1 engages the Reverse gear on Output shaft 2 which connects to the differential for a reverse gear ratio of 2.99:1

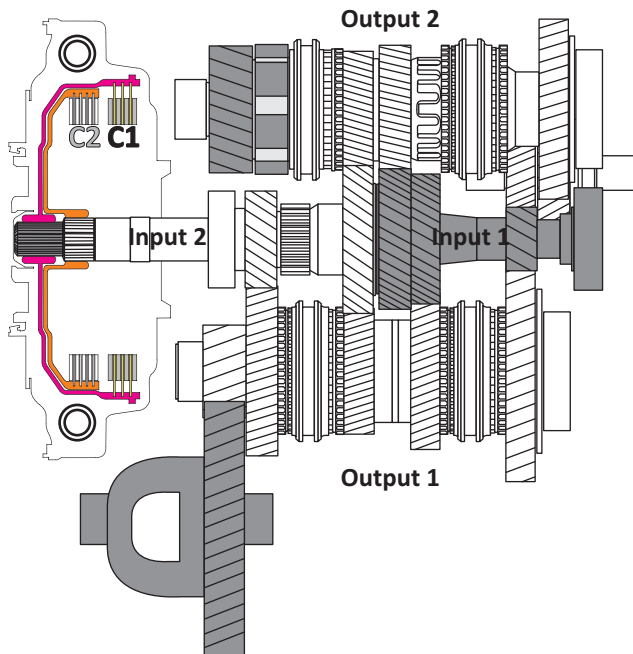

### **Park Gear:**

Even gear shift fork 4 moves towards the Park Gear on Output shaft 2. A Park Pawl mechanically engages the Park Gear which locks the differential from moving in a forward or reverse rotation. Even gearshift fork 3 moves to the N position as well as Odd gearshift forks 1 and 2. This allows the C1 to be on driving Input Shaft 1 (Inner Shaft) in preparation for a garage shift into 1st or reverse.

*Note: All gear ratios were calculated based on tooth counts seen in figure 7*

Copyright © ATSG 2012

Figure 11





## Technical Service Information

### THE DOG-CLUTCH

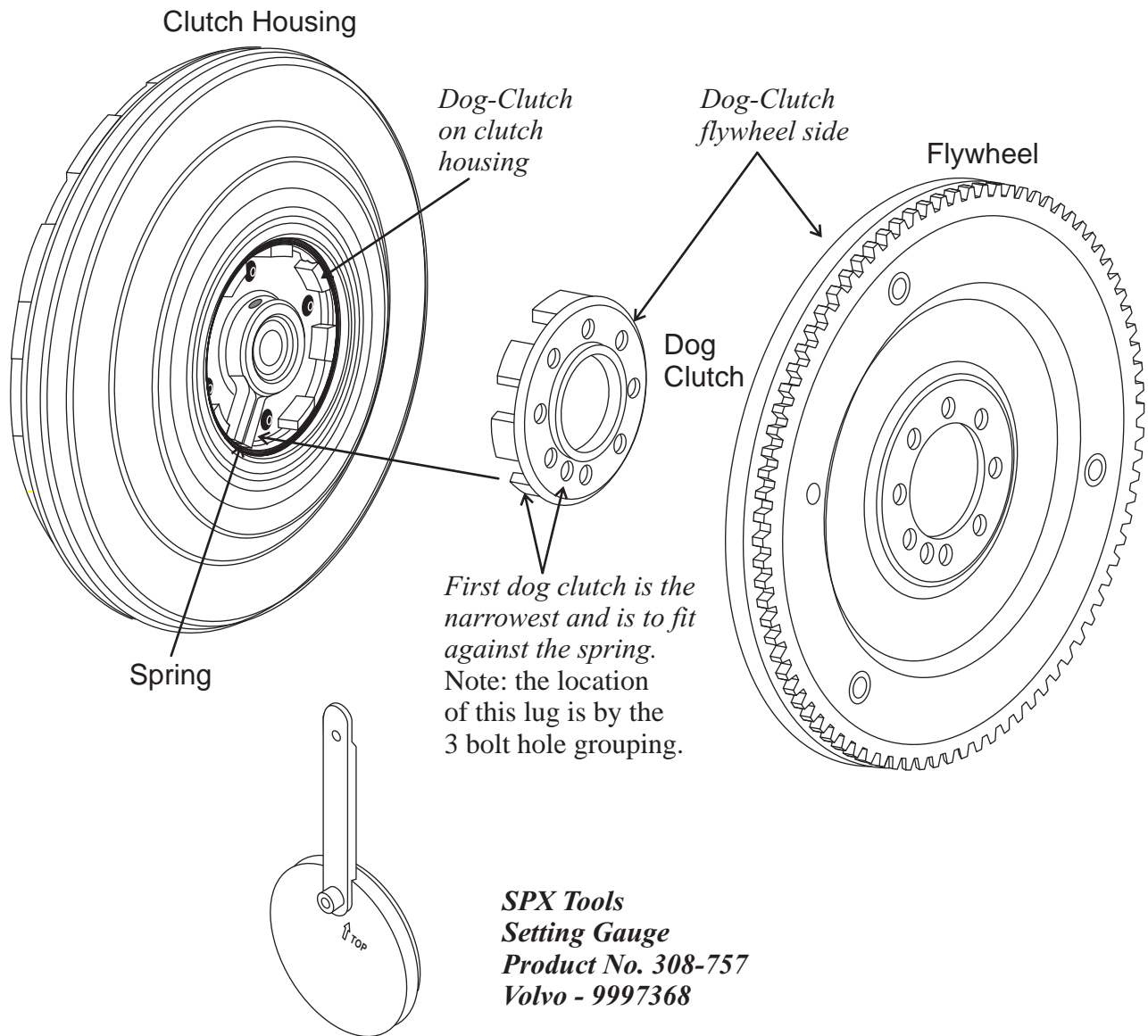

Unique to this transmission is the use of a dog-clutch (claw clutch) which acts as an interface between the transmission and engine.

The dog-clutch on the flywheel side consists of 8 dogs (claws) which is indexed to the 8 dogs (claws) in the clutch housing and is pre-loaded with a spring.

The interface is designed to absorb small shocks between the engine and transmission that can be transmitted through the vehicle.

Before the transmission is coupled to the engine, the first flywheel's first dog (claw), which is narrower is to be fitted against the spring in the clutch housing using special tool 308-757 from SPX Tools.

The function of the first dog (claw) on the flywheel is to pre-load the spring on the clutch housing, the other 7 dogs transfer the engine's torque to the transmission.

Copyright © ATSG 2012

Figure 12



# Technical Service Information

## REMOVING THE CLUTCH HOUSING

To remove the Double Clutch Drum assembly from the transmission begin by placing the selector lever into the Neutral Position.

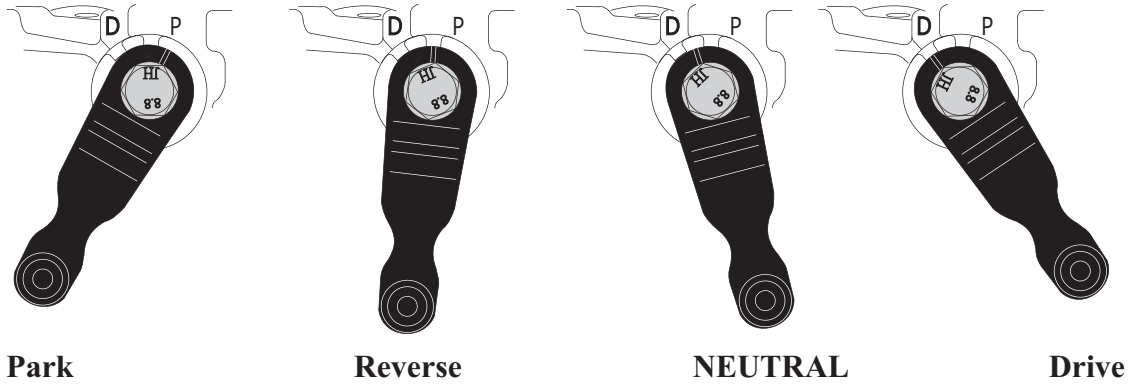

Remove the two detent bolts for shift rail gearshift forks 2 and 3. Once removed, look down into each of the holes to be sure that the shift rails are in the Neutral Position. If not, carefully use a suitable tool to place the rail into neutral.

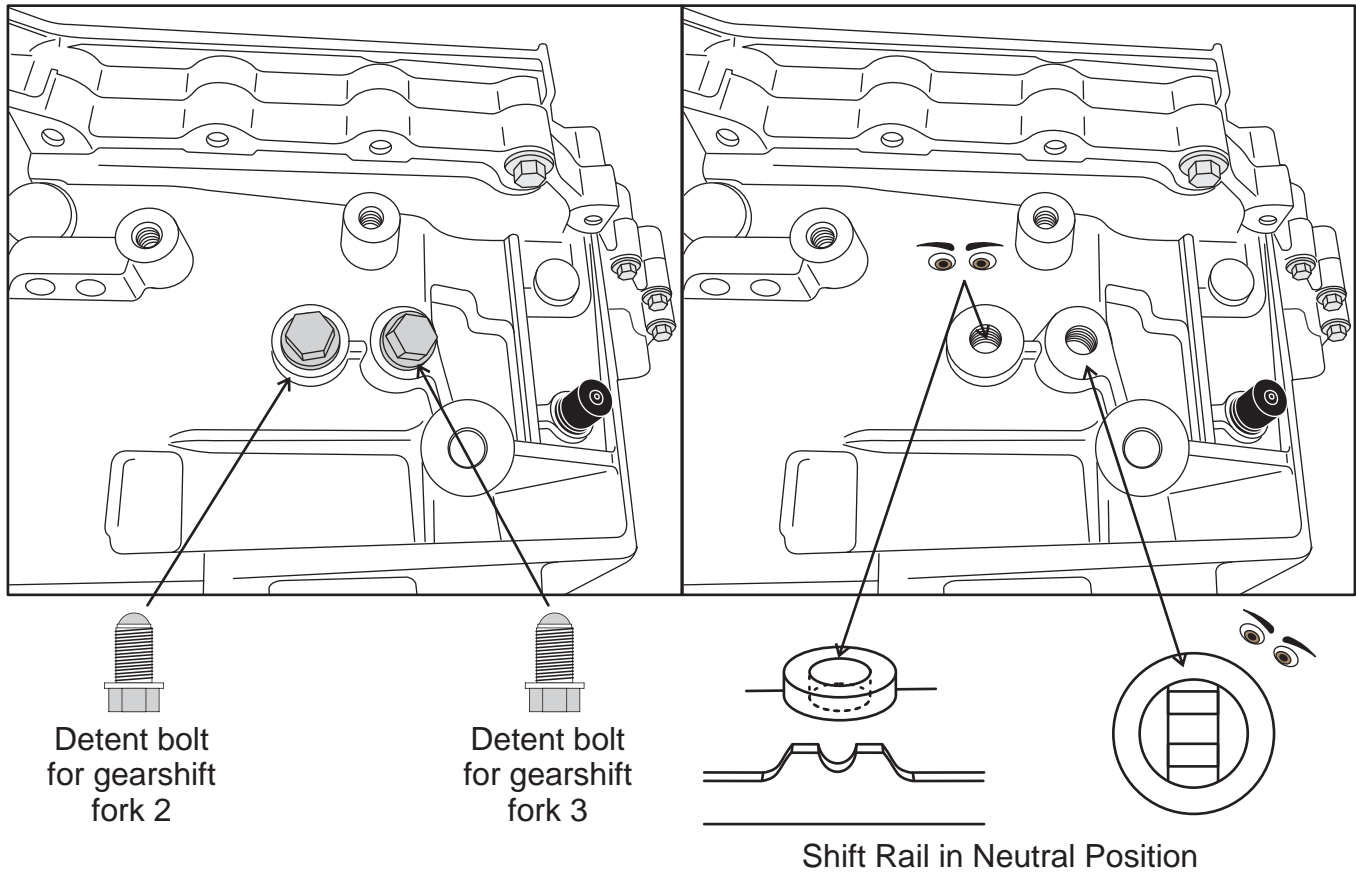

Copyright © ATSG 2012

Figure 13  
Automatic Transmission Service Group



## Technical Service Information

### REMOVING THE CLUTCH HOUSING

To remove the cover plate to gain access to the clutch housing remove the 3 retaining plates. Using a suitable tool carefully pry the cover out the transmission. The plate is sacrificial and will be damaged in the process.

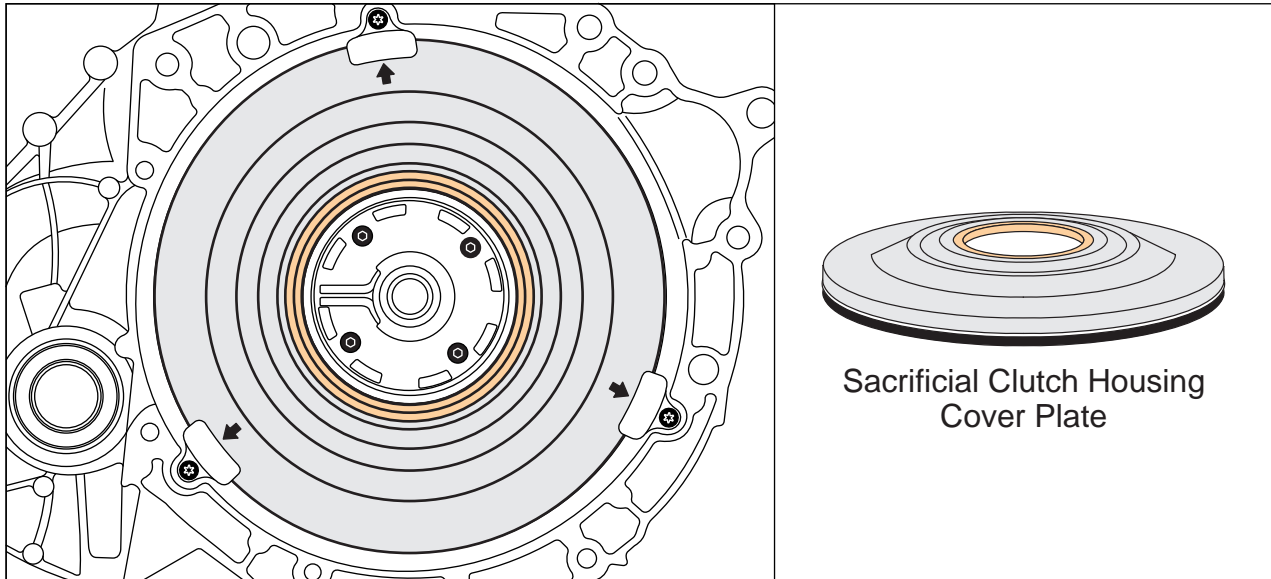

Using a pick remove the 4 rubber plugs from the clutch housing's special tool alignment holes. Once they are removed look into one of the holes. As you rotate the housing you will observe other internal alignment holes. When the housing's alignment hole and the two internal holes are aligned, outer legs to a spanner nut should be seen (See figure 15).

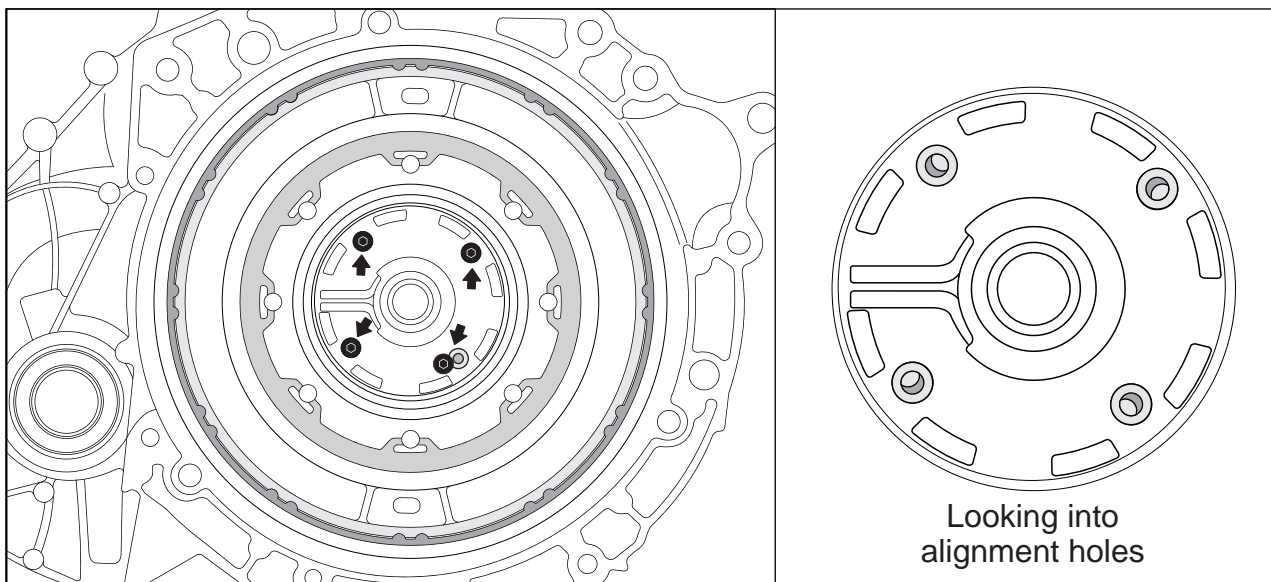

Copyright © ATSG 2012

Figure 14



# Technical Service Information

## REMOVING THE CLUTCH HOUSING

DCT450

C1 = Clutch 1, Odd gears & reverse

C2 = Clutch 2, Even gears

C1 C2

Alignment Holes

Spanner Nut

C2 Clutch  
C2 Balance  
C1 Balance  
C1 Clutch

Drum Support

Clutch Assembly C2

Lube

C1

C2

Balance

C1

Balance

Circuit Identification

Copyright © ATSG 2012

The double-clutch system has a damping device that connects the engine to the input side of the wet clutch system.

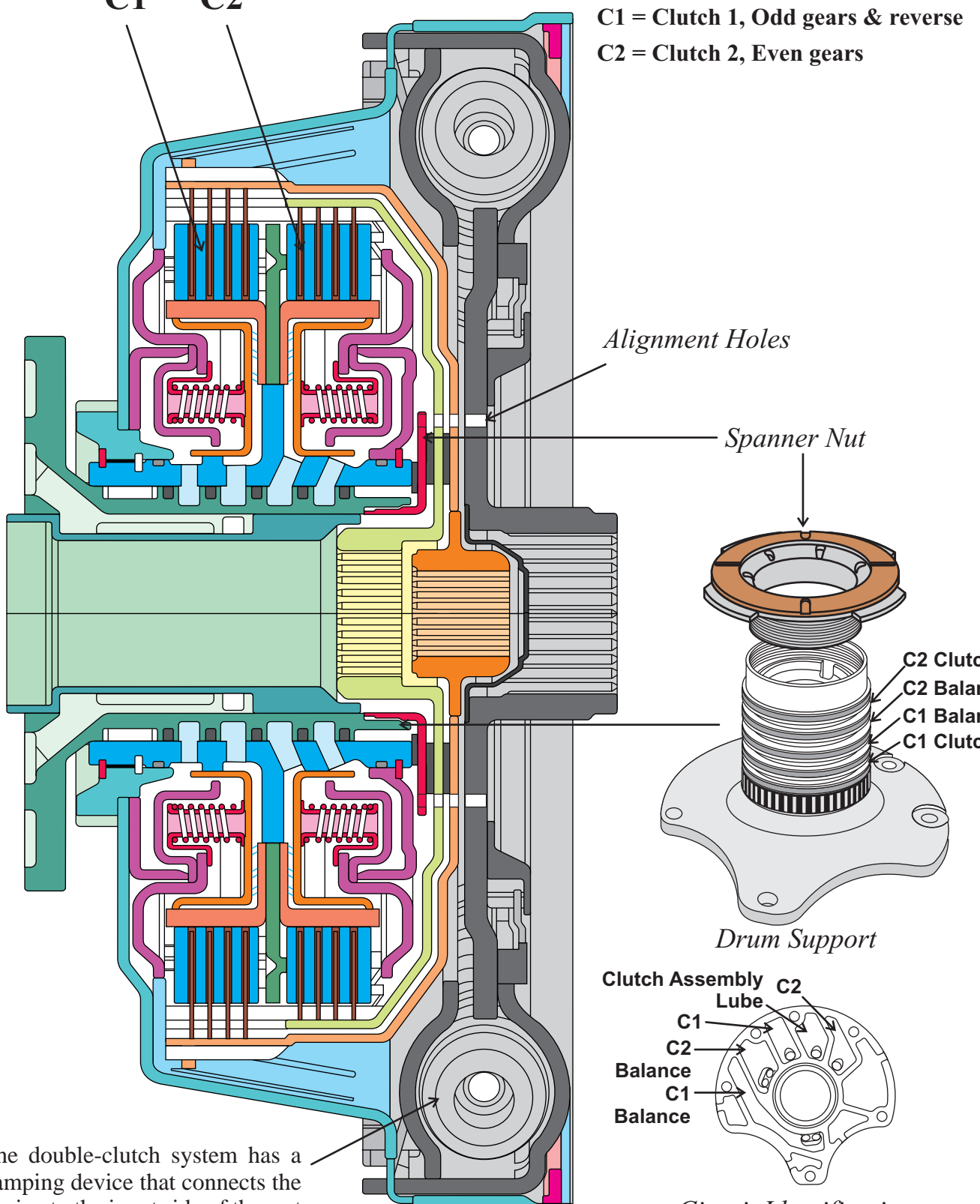

Figure 15



## Technical Service Information

### REMOVING THE CLUTCH HOUSING

Once holes are aligned in the clutch assembly, align the 4 pins from SPX special tool 308-763 into the clutch drum assembly as seen below.

*Note: The same procedure can be followed with removing the clutch housing in the DCT470 transmission however it will require a similar tool to the one used here with the DCT450. The center opening has a different dimension preventing this tool from working on both units.*

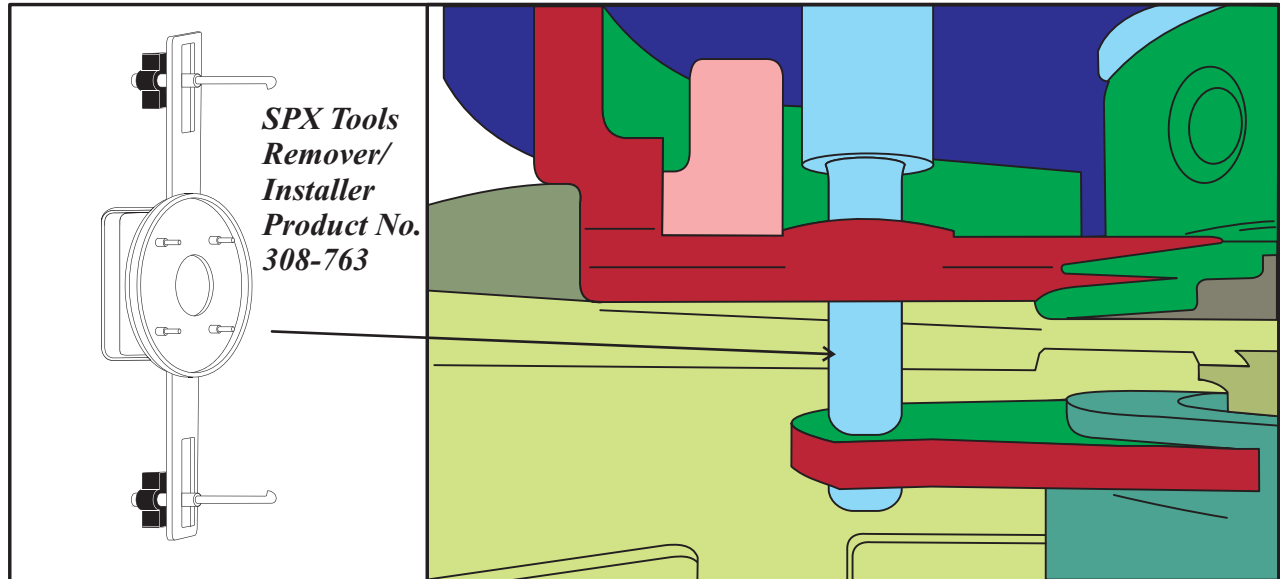

As the 4 pins are inserted and aligned into the clutch drum assembly, simultaneously align the attaching hooks or claws into the slots provided along the outside edge of the clutch assembly. Once installed, screw down on the claws with even tension and secure the tool in place.

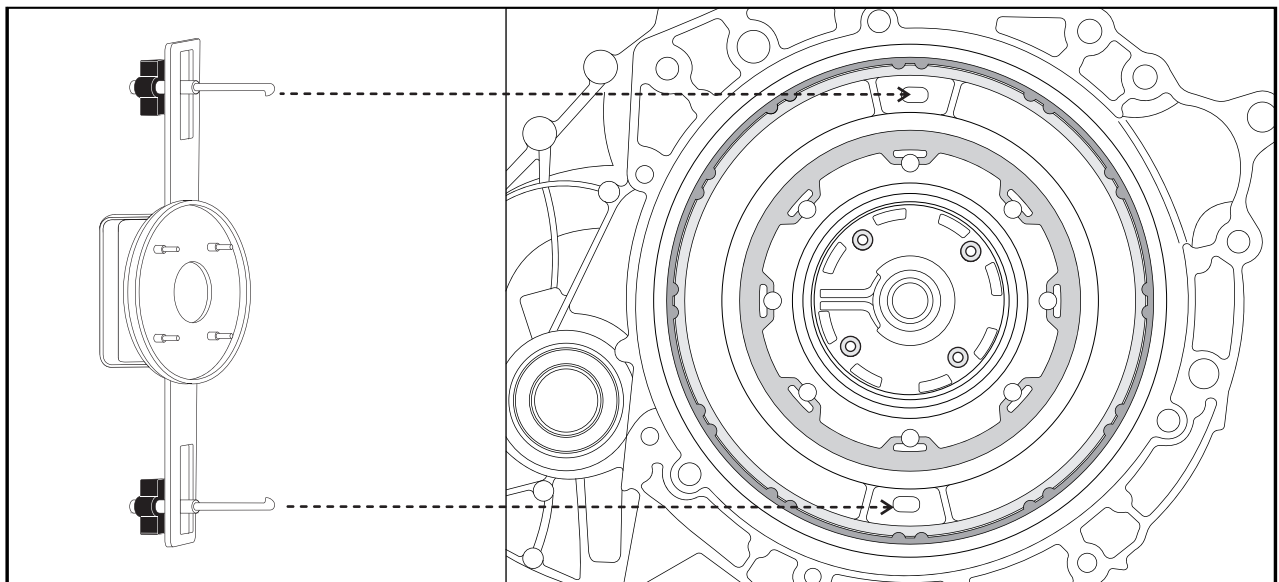

Copyright © ATSG 2012

Figure 16

Automatic Transmission Service Group





## Technical Service Information

### REMOVING THE CLUTCH HOUSING

Once the tool is in place, grip the handle and give the drum assembly a sharp quarter turn clockwise until it locks to the stop and then a sharp quarter turn counter-clockwise so as to release the assembly for removal.

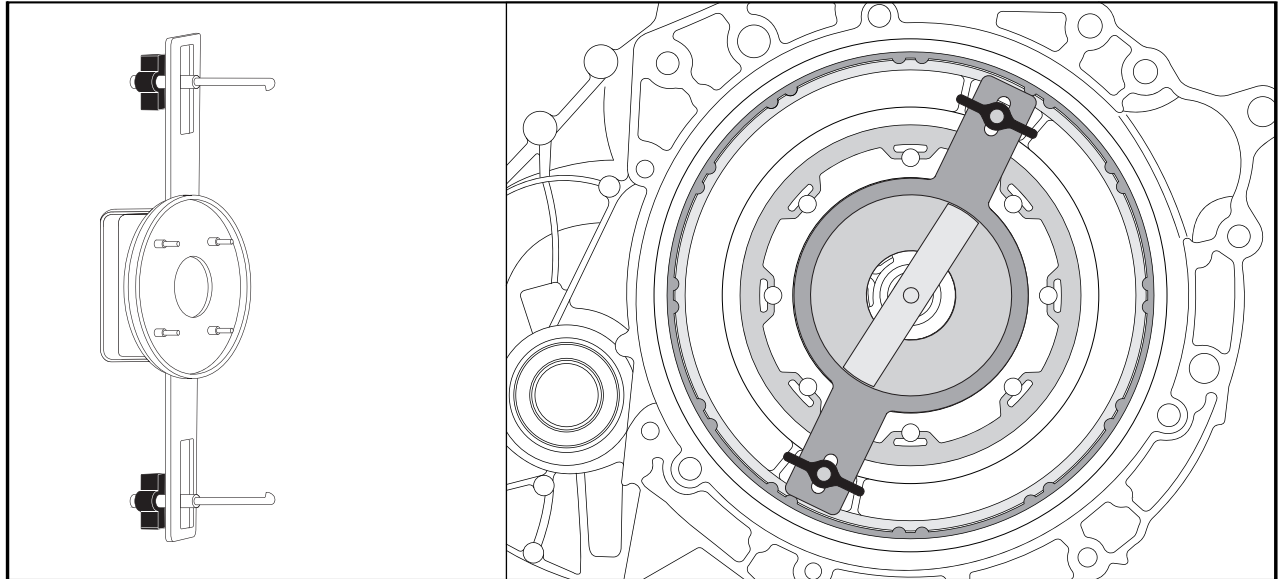

When the drum assembly's lock has been released, turn the assembly counter clock-wise approximately 8 full turns at which time the assembly can be removed from the transmission.

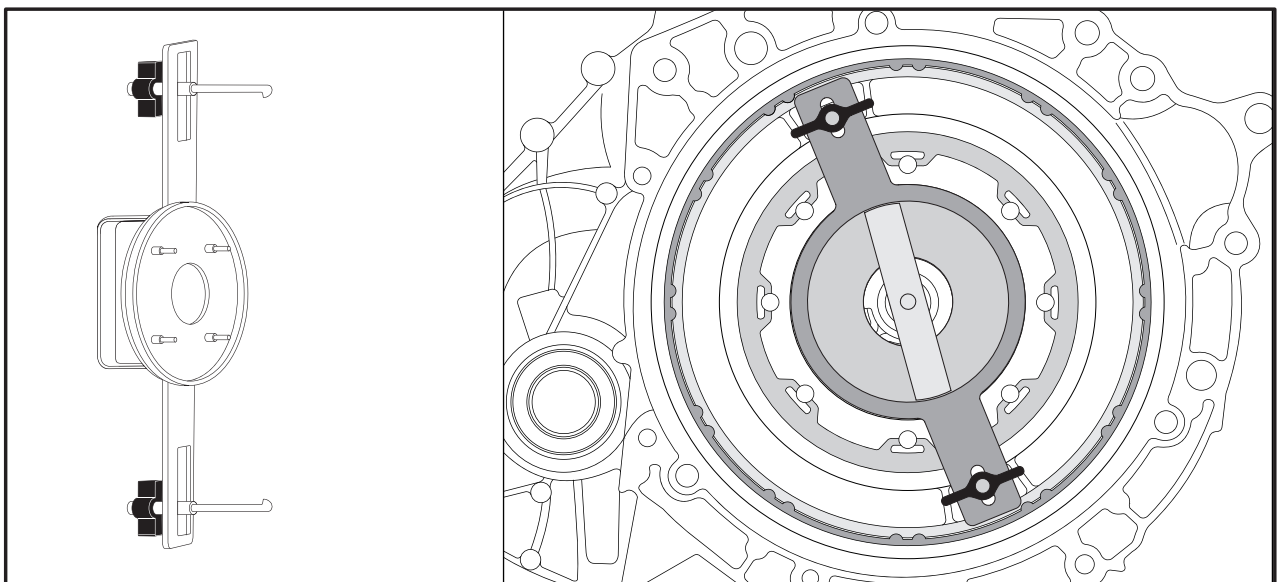

Copyright © ATSG 2012

Figure 17



## Technical Service Information

### REMOVING THE CLUTCH HOUSING

After approximately 8 full counter-clockwise rotations, the weight of the drum assembly should be felt. This indicates that the spanner nut has been fully unscrewed from the drum support at which time the assembly can be carefully removed from the transmission housing and set aside.

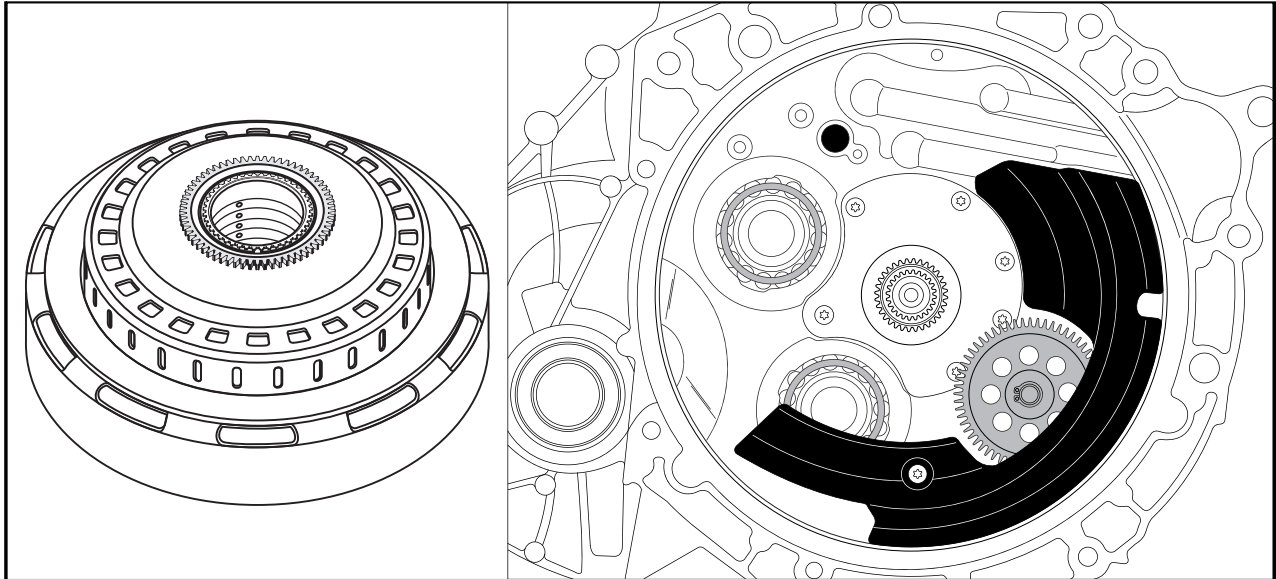

With the drum assembly out of the transmission, the special tool can be removed. The drum support to clutch drum assembly needle bearing usually remains inside the drum assembly. Be sure to locate it and set it aside to prevent it from being lost or damaged.

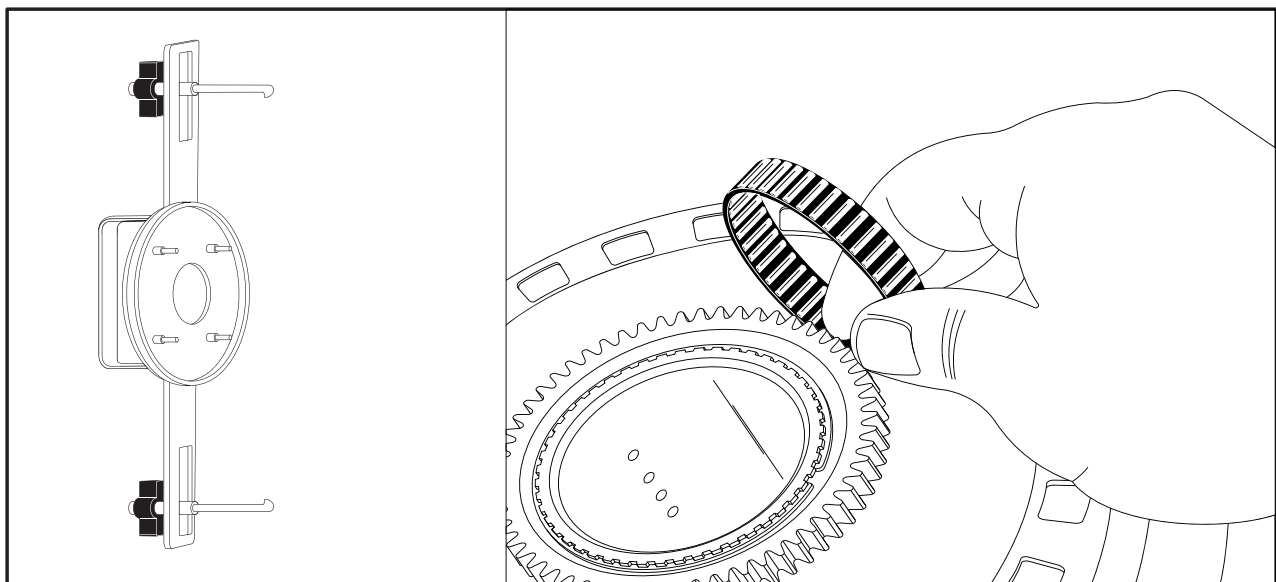

Copyright © ATSG 2012

Figure 18



# Technical Service Information

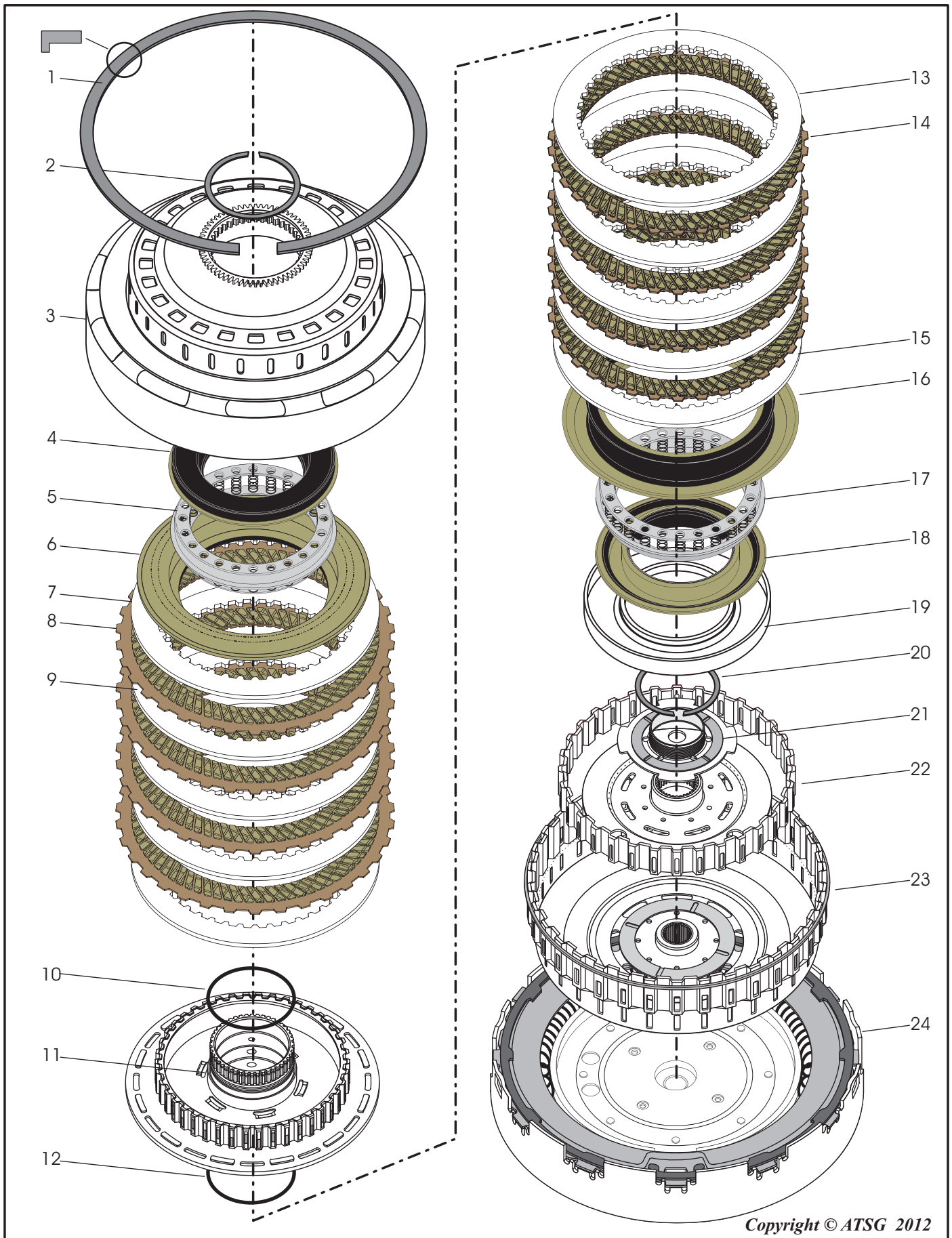

Copyright © ATSG 2012

Figure 19  
Automatic Transmission Service Group



## Technical Service Information

### C1/C2 CLUTCH DRUM ASSEMBLY LEGEND

- |  |  |
|--|--|
| 1. Clutch Cover Snap Ring (outer lip down) | 13. C2 Steel Plate [0.077"] (4 required)   |
| 2. Snap Ring                               | 14. C2 Friction Plate (4 required)         |
| 3. Clutch Cover                            | 15. C2 Apply Plate [0.087"]                |
| 4. C1 (Odd Clutch) Molded Piston           | 16. C2 (Even Clutch) Molded Balance Piston |
| 5. C1 (Odd Clutch) Return Spring           | 17. C2 (Even Clutch) Return Spring         |
| 6. C1 (Odd Clutch) Molded Balance Piston   | 18. C2 (Even Clutch) Molded Piston         |
| 7. C1 Apply Plate [0.087"]                 | 19. C2 (Even Clutch) Piston Sleeve         |
| 8. C1 Friction Plate (4 required)          | 20. Snap Ring                              |
| 9. C1 Steel Plate [0.077"] (4 required)    | 21. Spanner Nut                            |
| 10. C1 O'ring                              | 22. C2 Clutch Hub                          |
| 11. C1/C2 Distributor Housing              | 23. C1 Clutch Hub                          |
| 12. C2 O'ring                              | 24. C1/C2 Clutch Dampener Plate            |

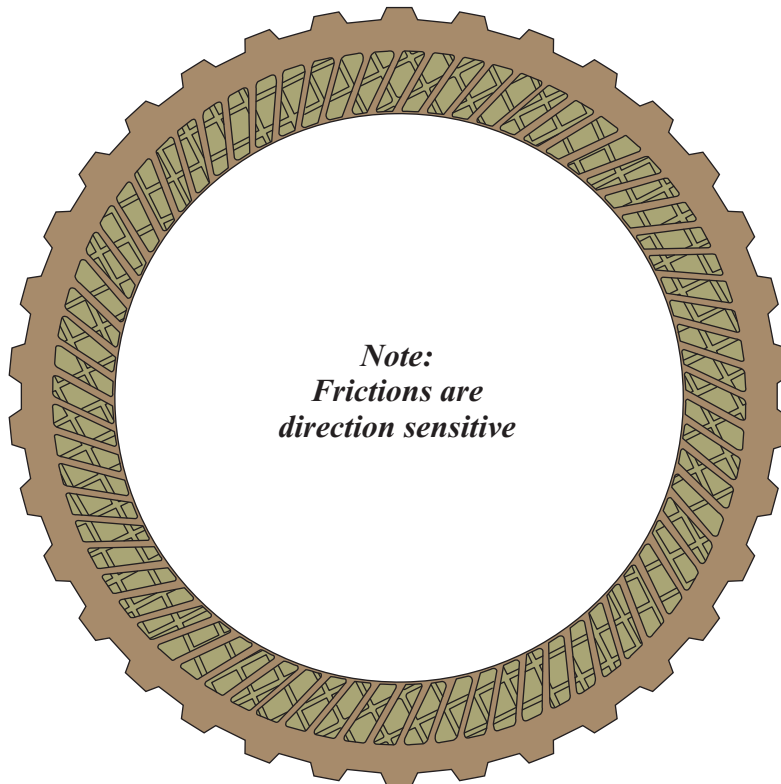

Copyright © ATSG 2012

Figure 20



## Technical Service Information

### BOLT ID FOR REMOVING THE VALVE BODY ASSEMBLY

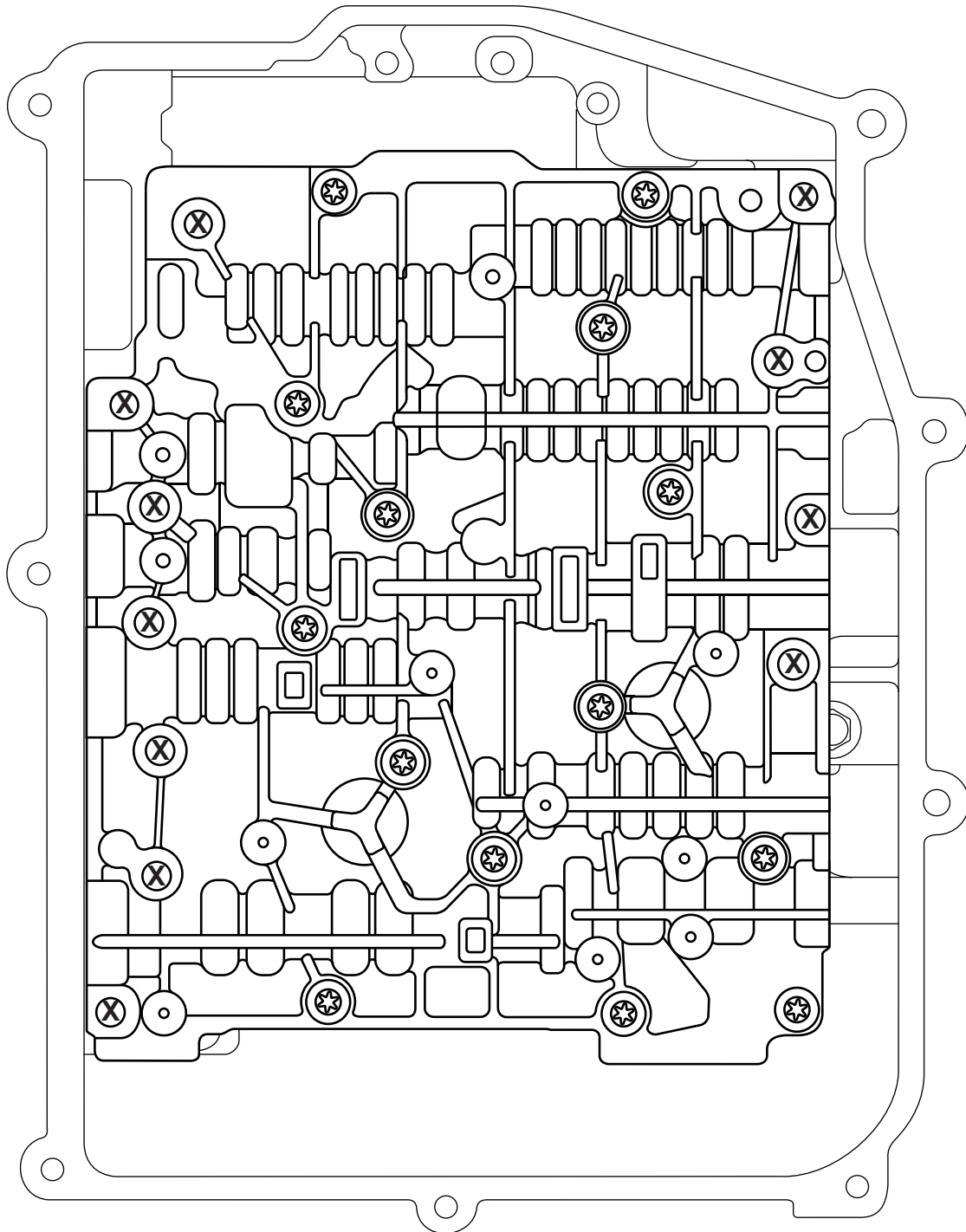

To remove the valve body assembly, first unplug the clutch drum speed sensor (which is also an engine speed sensor) from the Mechatronic unit. Then remove that TRS attaching bolt from the top of the case (See Figure 6). The 11 valve body to case bolts identified by the X marks seen above can now be removed (*same with the DCT470*). Once removed carefully pull the valve body far enough towards you to clear the sensors on the TCM that protrude deep into the case. There are long alignment pins mounted in the case to assist in this process. The locations of these pins are identified in figure 22.

Copyright © ATSG 2012

Figure 21





# Technical Service Information

## DCT450 CASE PASSAGE IDENTIFICATION

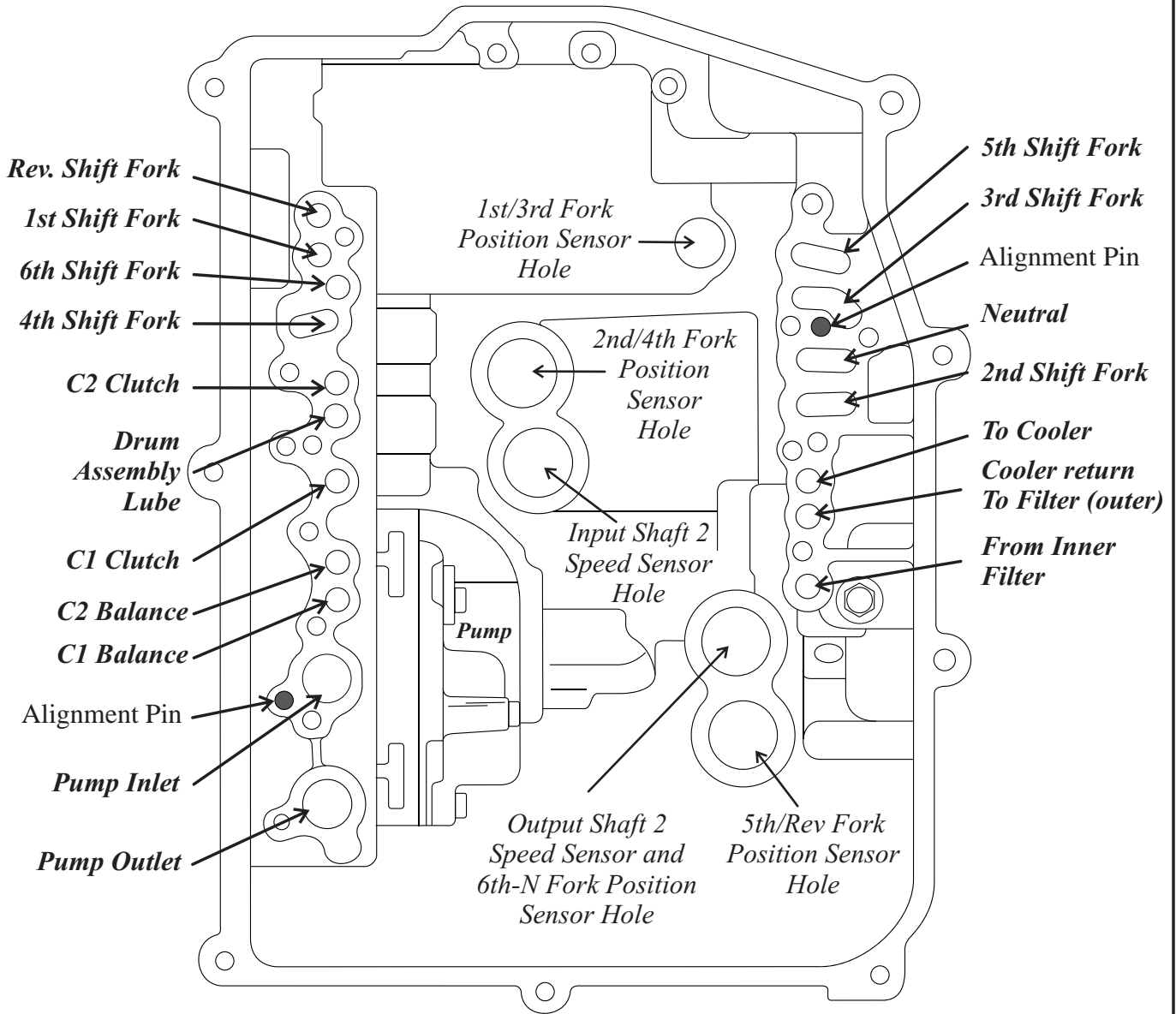

Copyright © ATSG 2012

Figure 22

Automatic Transmission Service Group





## Technical Service Information

### GEARSHIFT FORKS

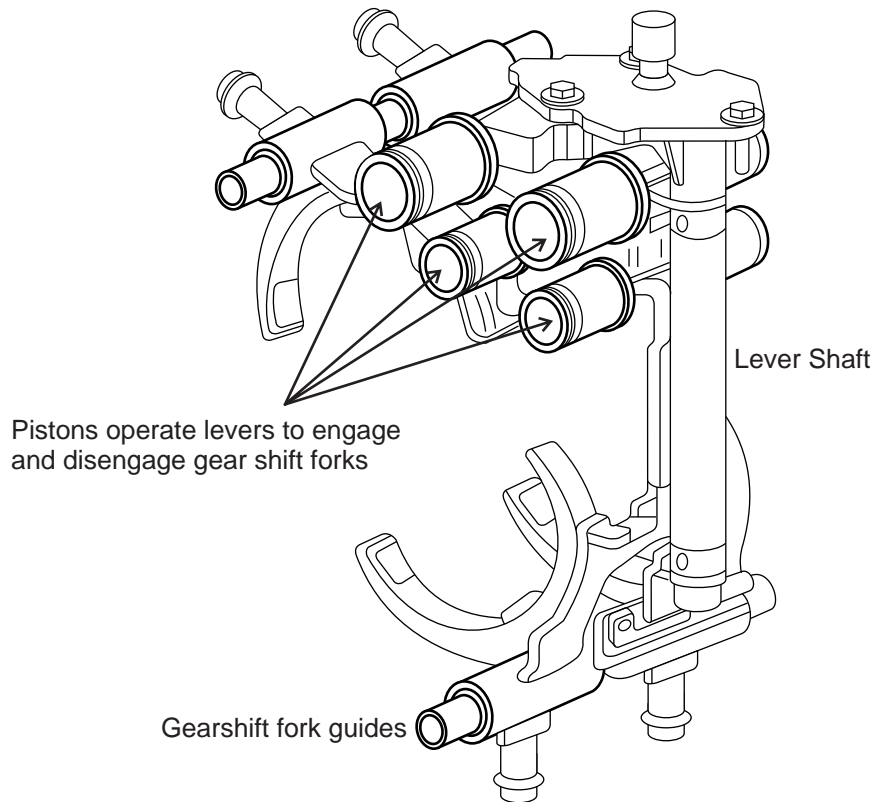

*Gearshift fork lever arrangements will differ within the Getrag family*

There are 4 gearshift forks in the transmission. The Transmission control module (TCM) activates solenoids, which in turn activate hydraulics so that the gearshift forks mechanically engage the gears. Pistons are hydraulically charged to operate levers which engage and disengage gearshift forks. These pistons do not act on the gearshift fork themselves but rather they work on strategically placed lever points. Each gearshift fork has guided ends held in place by pockets in both case halves.

The gears' positions per gearshift fork are:

Gearshift fork 1 (Odd): R-N-5

Gearshift fork 2 (Odd): 3-N-1

Gearshift fork 3 (Even): 2-N-4

Gearshift fork 4 (Even): P-N-6

Both an Even and an Odd gear can be activated at the same time and are then handled in parallel. 5th gear and N are blocked if R-gear is engaged, and N-gear and 1 are blocked if 3rd gear is engaged. The same is true with the even gears.

Copyright © ATSG 2012

Figure 23



# Technical Service Information

## GEARSHIFT FORKS

There are a total of 8 pistons which are used to engage and disengage 4 gearshift forks. First and reverse gears utilize larger diameter pistons than do all the remaining pistons. Piston construction is a hollow plastic type with rubber molded seals for hydraulic retention. The plastic tip works against a steel surface and is prone to wear. The piston is thick enough in this area to not spring a leak but can squash down and possibly cause a shifting concern.

Note: There are two pins located within the gearshift fork lever system that are used to hold one gearshift fork in a disengaged state while the opposite gearshift fork is engaged. One pin is longer than the other making their proper placement obvious. The problem is forgetting to put them in place during reassembly.

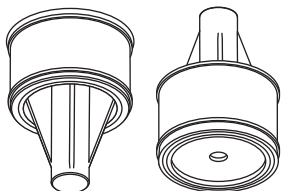
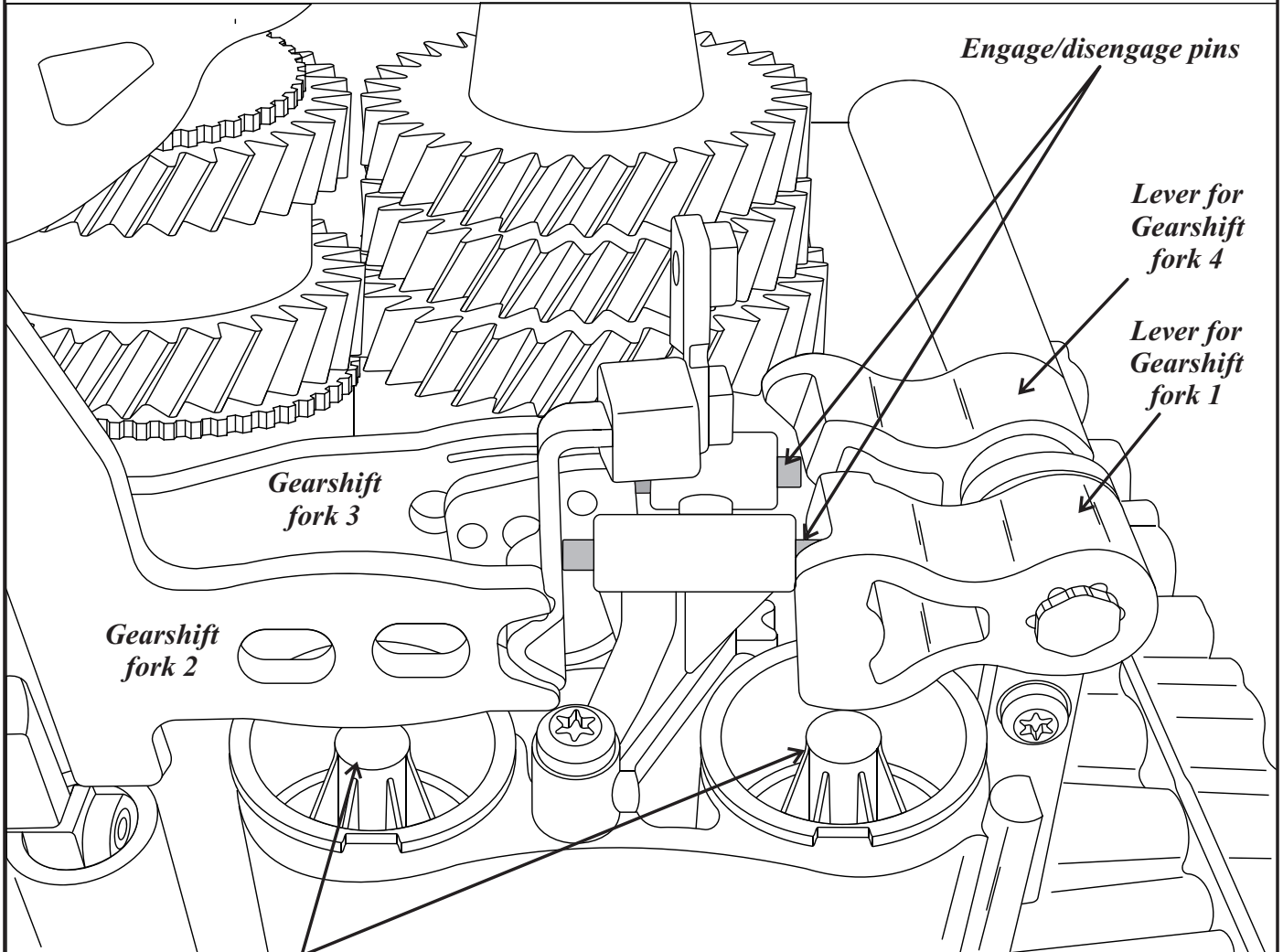

**Gearshift forks 1 & 2**  
**Pistons for 1st and Reverse only**  
 36.32mm (1.430") width  
 41.35mm (1.625") length

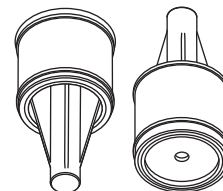

**All other Pistons**  
 36.32mm (1.115") width  
 41.35mm (1.625") length

Copyright © ATSG 2012

Figure 24



# Technical Service Information

## DCT450 GEARSHIFT FORKS

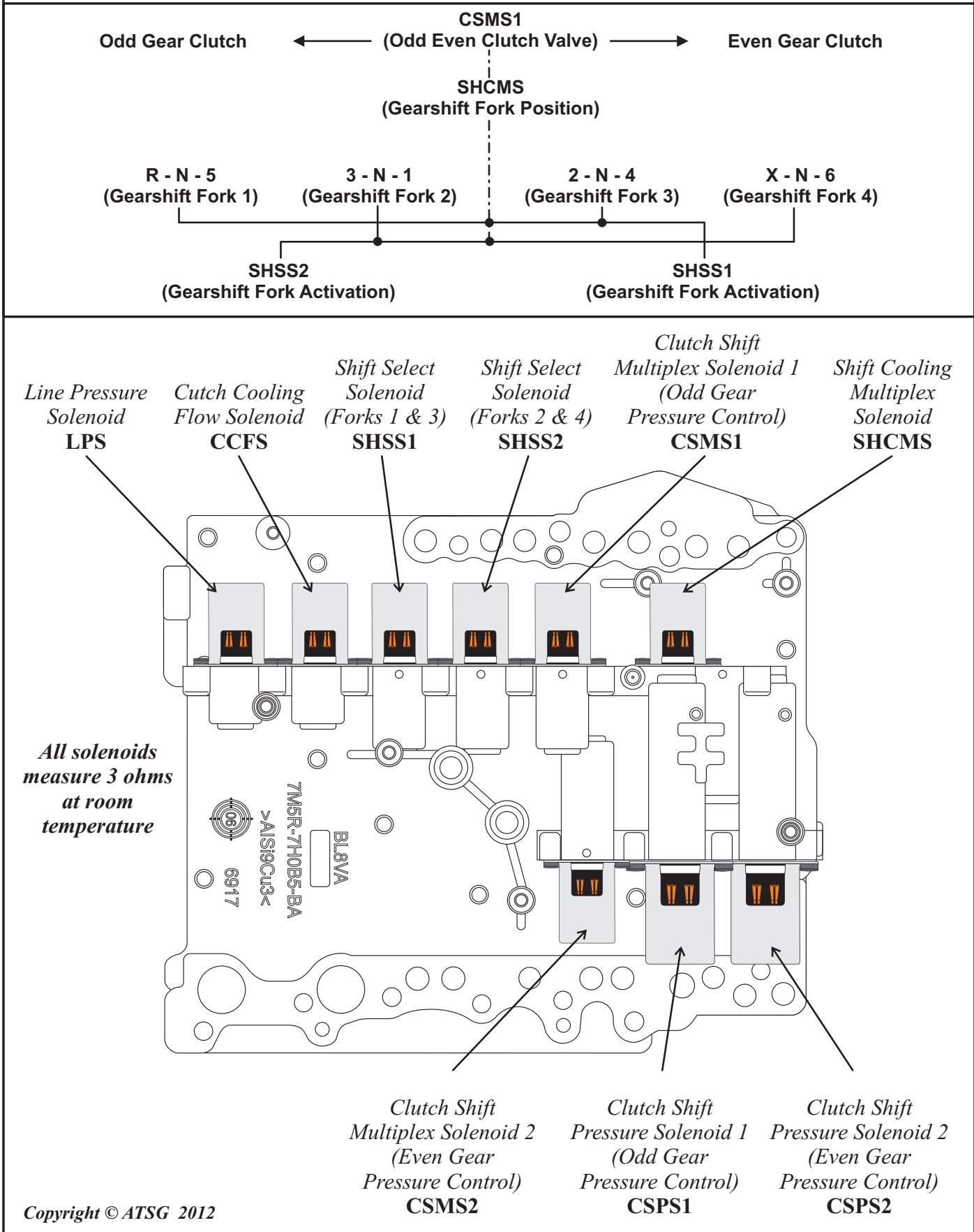

Copyright © ATSG 2012

Figure 25

## Technical Service Information

### SOLENOID FUNCTION

- System pressure solenoid **LPS** (Line Pressure Solenoid) - Controls system pressure in the transmission by directing the hydraulic oil to clutch, shifting, cooling flow, and then returning the oil to the oil sump.
- Solenoid for cooling flow **CCFS** (Clutch Cooling Flow Solenoid) - Controls hydraulic oil for cooling of clutches.
- Multiplex solenoid **SHCMS** (Shift Cooling Multiplex Solenoid) - Controls position of gearshift forks as well as cooling of clutch.
- Multiplex solenoid **CSMS1** (Clutch Shift Multiplex Solenoid) - Leads the pressure between Odd clutch and shifting, activates Odd gears as well as controls cooling flow for clutches.
- Multiplex solenoid **CSMS2** (Clutch Shift Multiplex Solenoid) - Leads the pressure between even clutch and shifting, controls cooling flow for clutches and can turn off the valve for dumping clutch pressure **CPCUT** to regain clutch pressure.
- Solenoid for clutch pressure Odd gears **CSPS1** (Clutch Shift Pressure Solenoid) - Controls hydraulic pressure for Odd clutch or shifting.
- Solenoid for clutch pressure even gears **CSPS2** (Clutch Shift Pressure Solenoid) - Controls hydraulic pressure for even clutch or shifting.
- Valve for dumping clutch pressure **CPCUT** (Clutch Pressure Cut) - Safety valve that controls pressure-dumping in the hydraulic system.
- Shift solenoid **SHSS1** (Shift Select Solenoid) - Controls shifting for gearshift fork 1 and 3.
- Shift solenoid **SHSS2** (Shift Select Solenoid) - Controls shifting for gearshift fork 2 and 4.

#### Closed/open solenoids

The solenoids that are closed/open are the CSMS1, CSMS2, SHCMS, SHSS1 and SHSS2. These have only 2 positions, completely closed or fully open. The solenoids control valves that lead the hydraulic pressure to the desired system. Depending on system pressure and temperature, the Transmission control module (TCM) calculates the current that needs to be triggered to respective solenoid. The triggered current to the solenoids is not returned, which means that diagnostics of the solenoids is limited to only being able to see if they are off or on.

#### Linear solenoids

Linear solenoids (CCFS, LPS, CPS1 and CPS2) are controlled by a pulse-width modulated (PWM) current to enable linear or gradual control of the hydraulic pressure. The pulse-width modulated current induces a magnetic field that moves a core inside the solenoid. The solenoid can control the pressure by gradually opening or closing valves. The triggered current to the solenoids is returned to Transmission control module (TCM), which means that more advanced diagnosis is possible.



# Technical Service Information

## DCT450 COMPLETE VALVE BODY AND SOLENOID IDENTIFICATION

**CSPS solenoids  
(2 Required)**

7070 TM07/226  
7M5R-7G136-CA

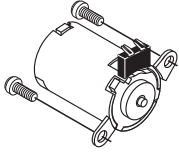

**All other solenoids  
(5 Required)**

8270 TM07/234  
7M5R-7G484-DA

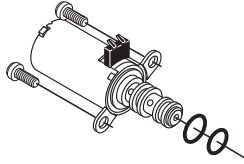

**LPS & CCFS solenoids  
(2 Required)**

8270 TM07/296  
7M5R-7G383-DA

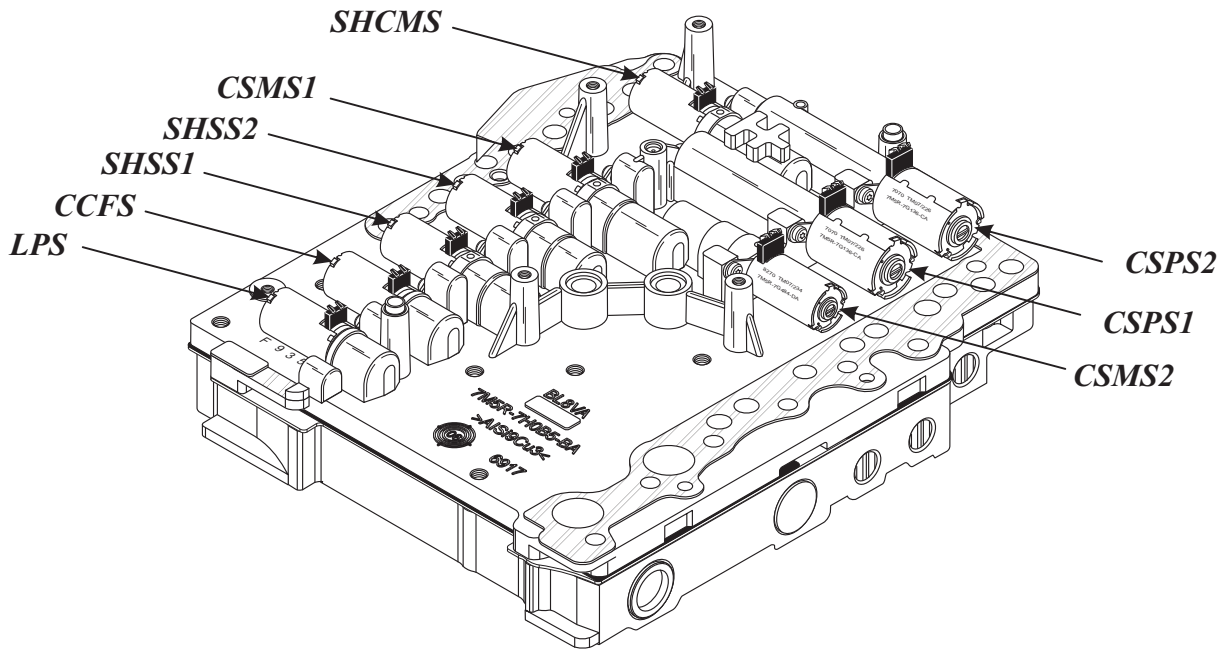
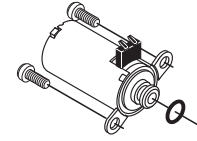

*The Line Pressure Solenoid not listed in the chart is turned on to drop line pressure throughout various shift sequences as needed for smooth shift transitions.*

*The SHCMS On/Off sequence listed below is different than what Volvo information provides. This sequence was determined via a hydraulic schematic produced by ATSG.*

Gearshift Patterns	Activated Solenoids						
	SHCMS	SHSS1	SHSS2	CSMS1	CSMS2	CSPS1	CSPS2
Engage 1	On	Off	On	On	Off	High	X
Engage 2	Off	On	Off	Off	On	X	High
Engage 3	Off	Off	On	On	Off	High	X
Engage 4	On	On	Off	Off	On	X	High
Engage 5	On	On	Off	On	Off	High	X
Engage 6	On	Off	On	Off	On	X	High
Park/Neutral	Off	Off	On	Off	On	X	High
Engage R	Off	On	Off	On	Off	High	X

Copyright © ATSG 2012

Figure 26



# Technical Service Information

## DCT450 VALVE BODY ASSEMBLY

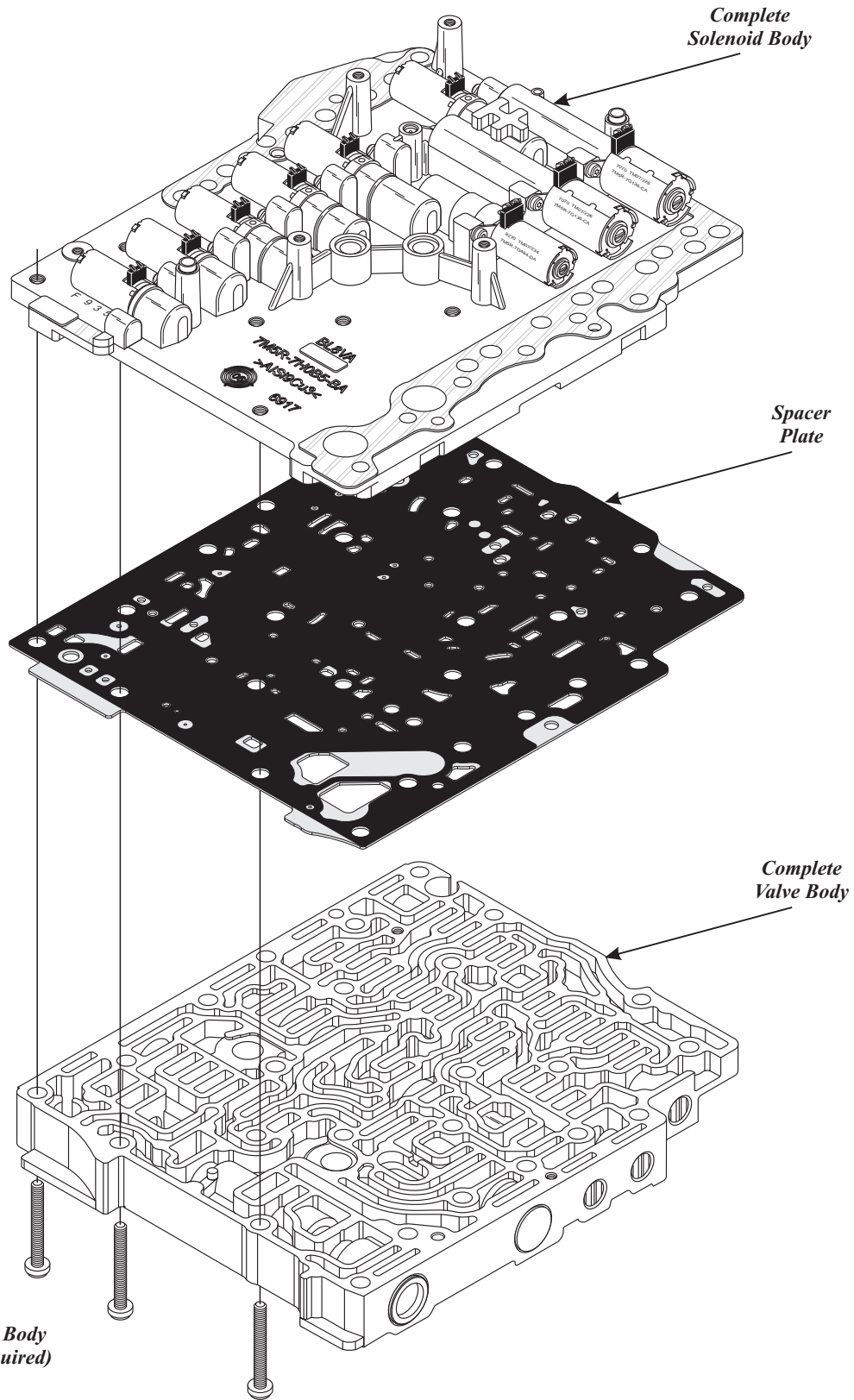

Valve Body To Solenoid Body Retaining Bolts (14 Required)

Copyright © ATSG 2012

Figure 27





# Technical Service Information

## DCT450 SOLENOID BODY EXPLODED VIEW

### SOLENOID BODY SPRING SPECIFICATIONS

SPRING NO. 314 & 319  
 Free Length = .260"  
 Spring Diameter = .446"  
 Wire Diameter = .046"  
 Approx Coils = 4 (NONE)

SPRING NO. 316  
 Free Length = .289"  
 Spring Diameter = .199"  
 Wire Diameter = .018"  
 Approx Coils = 6 (NONE)

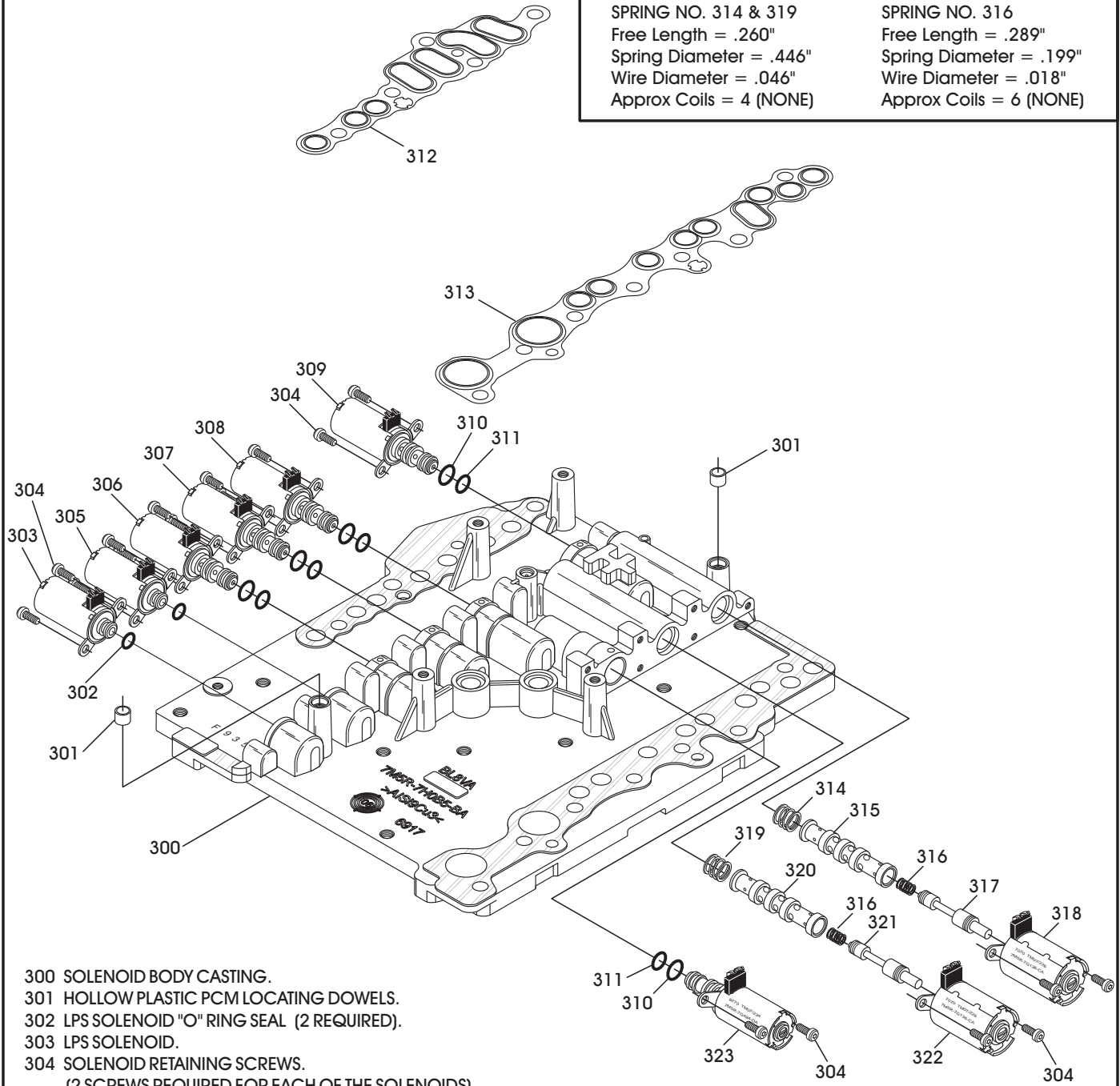

- 300 SOLENOID BODY CASTING.
- 301 HOLLOW PLASTIC PCM LOCATING DOWELS.
- 302 LPS SOLENOID "O" RING SEAL (2 REQUIRED).
- 303 LPS SOLENOID.
- 304 SOLENOID RETAINING SCREWS.  
(2 SCREWS REQUIRED FOR EACH OF THE SOLENOIDS)
- 305 CCFS SOLENOID.
- 306 SHSS1 SOLENOID.
- 307 SHSS2 2 SOLENOID.
- 308 CSMS1 SOLENOID.
- 309 SHCMS SOLENOID.
- 310 TYPE 2 SOLENOID LARGE "O" RING SEAL.
- 311 TYPE 2 SOLENOID SMALL "O" RING SEAL.  
(LARGE AND SMALL SEAL REQUIRED FOR EACH TYPE 2 SOL)
- 312 SHORT STEEL "RIBBED" VALVE BODY TO CASE GASKET.
- 313 LONG STEEL "RIBBED" VALVE BODY TO CASE GASKET.

- 314 CPCS2 SOLENOID SLEEVE SPRING.
- 315 CPCS2 SOLENOID SLEEVE.
- 316 CPCS1 & 2 SOLENOID VALVE SPRING.
- 317 CPCS2 SOLENOID VALVE.
- 318 CPCS2 SOLENOID.
- 319 CPCS1 SOLENOID SLEEVE SPRING.
- 320 CPCS1 SOLENOID SLEEVE.
- 321 CPCS1 SOLENOID VALVE.
- 322 CPCS1 SOLENOID.
- 323 CSMS2 SOLENOID.

Copyright © ATSG 2012

Figure 28



# Technical Service Information

## DCT450 LOWER VALVE BODY RETAINER AND SMALL PARTS LOCATIONS

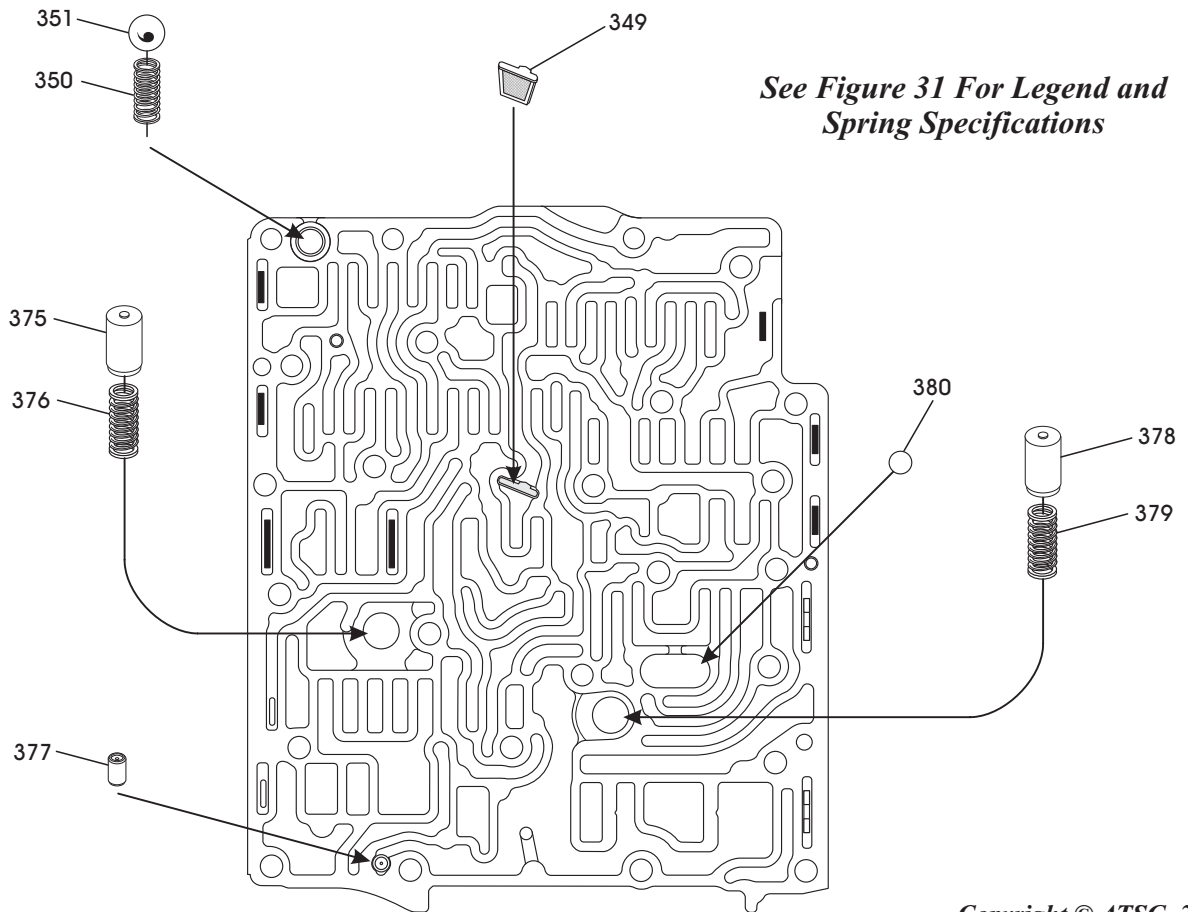
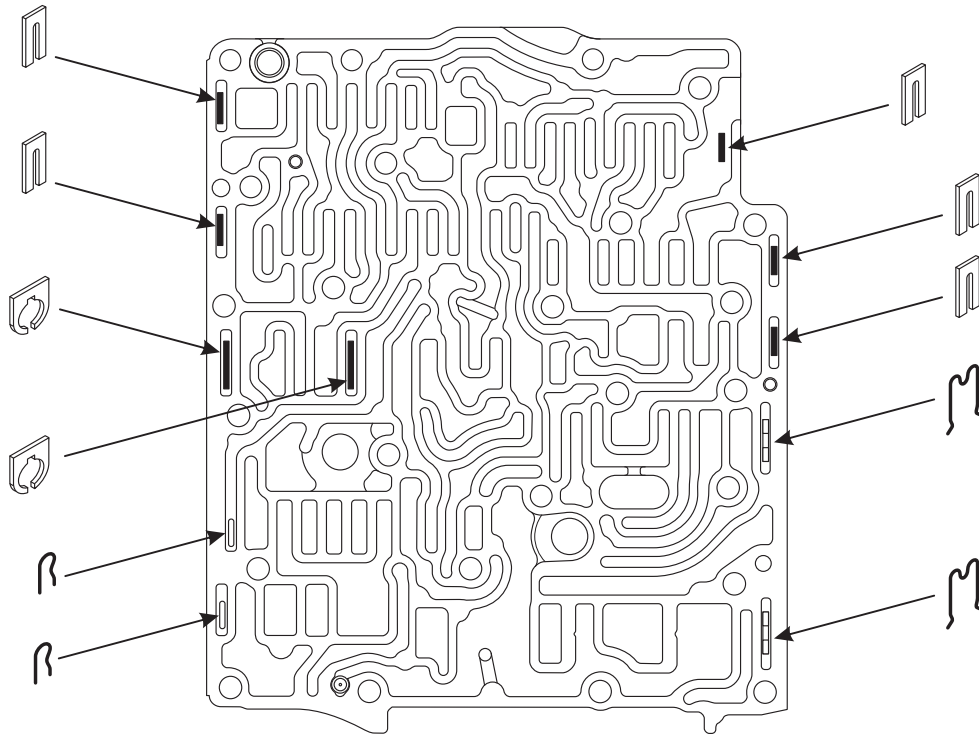

Copyright © ATSG 2012

Figure 29



# Technical Service Information

## DCT450 MAIN VALVE BODY, EXPLODED VIEW

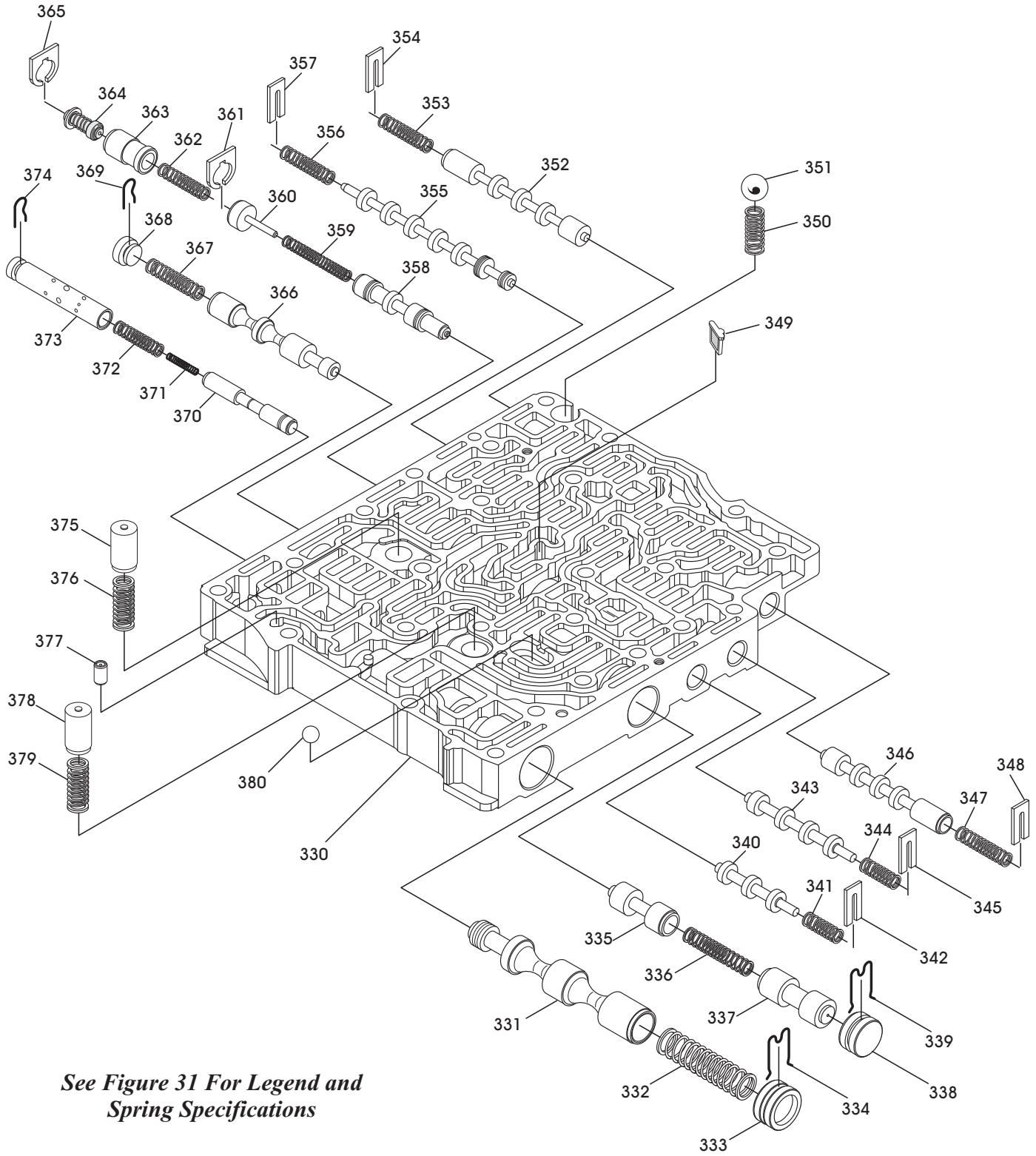

*See Figure 31 For Legend and Spring Specifications*

Copyright © ATSG 2012

Figure 30



# Technical Service Information

## DCT450 MAIN VALVE BODY LEGEND

330 MAIN VALVE BODY CASTING.	358 PRESSURE CUT SAFETY VALVE.
331 PRIMARY PRESSURE REGULATOR VALVE.	359 PRESSURE CUT SAFETY VALVE SPRING.
332 PRIMARY PRESSURE REGULATOR VALVE SPRING.	360 PRESSURE CUT SAFETY VALVE BORE PLUG.
333 PRIMARY PRESSURE REGULATOR VALVE BORE PLUG.	361 BORE PLUG RETAINER.
334 PRIMARY PRESSURE REGULATOR VALVE BORE PLUG RETAINER.	362 THERMAL VALVE SPRING.
335 ODD EVEN SHIFT VALVE A.	363 THERMAL REACTION VALVE.
336 ODD EVEN SHIFT VALVE SPRING.	364 THERMAL BY-PASS VALVE.
337 ODD EVEN SHIFT VALVE B.	365 THERMAL BY-PASS VALVE RETAINER.
338 ODD EVEN SHIFT VALVE BORE PLUG.	366 SECONDARY PRESSURE REGULATOR VALVE.
339 ODD EVEN SHIFT VALVE BORE PLUG RETAINER.	367 SECONDARY PRESSURE REGULATOR VALVE SPRING.
340 C1 CLUTCH CONTROL VALVE.	368 SECONDARY PRESSURE REGULATOR VALVE BORE PLUG.
341 C1 CLUTCH CONTROL VALVE SPRING.	369 SECONDARY PRESSURE REGULATOR VALVE BORE PLUG RETAINER.
342 C1 CLUTCH CONTROL VALVE RETAINER.	370 CLUTCH COOLING CONTROL VALVE.
343 C2 CLUTCH CONTROL VALVE.	371 CLUTCH COOLING CONTROL VALVE INNER SPRING.
344 C2 CLUTCH CONTROL VALVE SPRING.	372 CLUTCH COOLING CONTROL VALVE OUTER SPRING.
345 C2 CLUTCH CONTROL VALVE RETAINER.	373 CLUTCH COOLING CONTROL VALVE SLEEVE ASSEMBLY.
346 EVEN FORK CONTROL VALVE.	374 CLUTCH COOLING CONTROL VALVE RETAINER.
347 EVEN FORK CONTROL VALVE SPRING.	375 LUBE PRESSURE RELIEF VALVE.
348 EVEN FORK CONTROL VALVE RETAINER.	376 LUBE PRESSURE RELIEF VALVE SPRING.
349 CSPTS 1 & 2, SHCMS SOLENOID SCREEN.	377 PLASTIC ORIFICE ASSEMBLY (.043" DIAMETER).
350 COMBINED DRAIN BALL SPRING.	378 LINE PRESSURE RELIEF VALVE.
351 COMBINED DRAIN BALL (STEEL), 12 MM (.472") DIAMETER.	379 LINE PRESSURE RELIEF VALVE SPRING.
352 ODD FORK CONTROL VALVE.	380 ODD EVEN SHUTTLE BALL (WHITE PLASTIC - .375" DIAMETER).
353 ODD FORK CONTROL VALVE SPRING.	
354 ODD FORK CONTROL VALVE RETAINER.	
355 ODD EVEN CONTROL VALVE.	
356 ODD EVEN CONTROL VALVE SPRING.	
357 ODD EVEN CONTROL VALVE RETAINER.	

## MAIN VALVE BODY SPRING SPECIFICATIONS

SPRING NUMBER 332 Free Length = 2.122" Spring Diameter = .474" Wire Diameter = .047" Approx Coils = 13 (NONE)	SPRING NUMBER 336 Free Length = 1.720" Spring Diameter = .285" Wire Diameter = .032" Approx Coils = 17 (NONE)	SPRING NUMBER 341 Free Length = 1.080" Spring Diameter = .299" Wire Diameter = .032" Approx Coils = 10 (NONE)	SPRING NUMBER 344 Free Length = 1.080" Spring Diameter = .299" Wire Diameter = .032" Approx Coils = 10 (NONE)
SPRING NUMBER 347 Free Length = 1.374" Spring Diameter = .284" Wire Diameter = .026" Approx Coils = 13 (NONE)	SPRING NO. 353 Free Length = 1.385" Spring Diameter = .284" Wire Diameter = .026" Approx Coils = 13 (NONE)	SPRING NO. 356 Free Length = 1.385" Spring Diameter = .284" Wire Diameter = .026" Approx Coils = 13 (NONE)	SPRING NUMBER 359 Free Length = 1.923" Spring Diameter = .238" Wire Diameter = .032" Approx Coils = 24 (NONE)
SPRING NUMBER 362 Free Length = 1.394" Spring Diameter = .284" Wire Diameter = .026" Approx Coils = 12 (NONE)	SPRING NUMBER 367 Free Length = 1.377" Spring Diameter = .284" Wire Diameter = .026" Approx Coils = 13 (NONE)	SPRING NUMBER 371 Free Length = .825" Spring Diameter = .165" Wire Diameter = .040" Approx Coils = 16 (NONE)	SPRING NUMBER 372 Free Length = 1.112" Spring Diameter = .278" Wire Diameter = .042" Approx Coils = 16 (NONE)

## MAIN VALVE BODY SPRING SPECIFICATIONS (*Small Parts - worm track side*)

SPRING NO. 350 Free Length = .863" Spring Diameter = .351" Wire Diameter = .028" Approx Coils = 10 (NONE)	SPRING NO. 376 Free Length = 1.180" Spring Diameter = .355" Wire Diameter = .085" Approx Coils = 10 (NONE)	SPRING NO. 379 Free Length = 1.180" Spring Diameter = .355" Wire Diameter = .085" Approx Coils = 10 (NONE)
---	--	--

\*Note: None = Spring is not colored

Copyright © ATSG 2012

Figure 31

Automatic Transmission Service Group

## Technical Service Information

### THE TRANSMISSION CONTROL MODULE (TCM)

The Transmission control module (TCM) is part of the Mechatronic unit (Valve body assembly, solenoids and TCM) located inside the transmission housing on the front of the transmission.

Two voltage supplies are provided to the TCM as well as a primary ground. It also connected to the network via CAN BUS. The TCM evaluates input signals from different sensors and control modules controlling the solenoids based on these signals.

The following components are integral to the TCM:

- Speed sensors
- Temperature sensor
- Pressure sensor
- Position sensors

#### **Speed sensors:**

- Engine RPM Sensor - Gives the TCM engine rpm's via the clutch drum housing.
- Speed sensor input shaft Odd gears - Gives the TCM information on input shaft rpm (after the C1 clutch) for Odd gears, 1, 3, 5, and R.
- Speed sensor input shaft even gears - Gives the TCM information on input shaft rpm (after the C2 clutch) for even gears, 2, 4, and 6.

#### **Temperature sensors:**

- Oil temperature sensor - Located on the TCM which provides information on transmission oil temperature.
- Temperature sensor control module (Hybrid sensor) - Integrated in the TCM gives information on the TCM's ambient temperature (*also a Temperature sensor redundancy signal*). The TCM uses temperature information to determine correct system pressure, for controlling clutch, for cold starts, and in position for overheating protection.

#### **Pressure sensor:**

- Pressure sensors - Give the TCM information on hydraulic pressure by the clutches. The TCM supplies the sensors with 5 volts. The sensors register the oil pressure for control of the clutch pressure so that the TCM can control the solenoids to provide correct clutch pressure for each clutch.

#### **Position sensors:**

- Position sensor gearshift fork - Give the TCM information on the position of the four gearshift forks that handle shifting in the transmission.

An important component belonging to the control system, but is located in the lever carrier in the middle console is the Gear Select Module (not to be confused with the internal TRS).

- Gear selector module (GSM) - Gives Transmission control module (TCM) information on locking of P as well as manual shifting.
- Inside the transmission and part of the TCM is the Transmissions Range Sensor (TRS) that provides that actual P R N D gear selection.





# Technical Service Information

## FORD/VOLVO TCM SENSOR IDENTIFICATION AND LOCATION

The TCM supplies this Hall Effect sensor with 7.2 volts. The sensor generates square waves of direct voltage at the rate that the input shaft's gear teeth pass the sensor. When a gear tooth passes, the signal becomes high (higher than 4.9 V), and when the gap between teeth passes the signal becomes low (lower than 1.6 V).

The TCM interprets the frequency which may vary between 3.5 Hz - 8 kHz to determine the rpm of the input shaft from the engine.

The sensors are designed to handle speeds between 0 - 12000 rpm.

The Sensor is hard wired into the TCM.

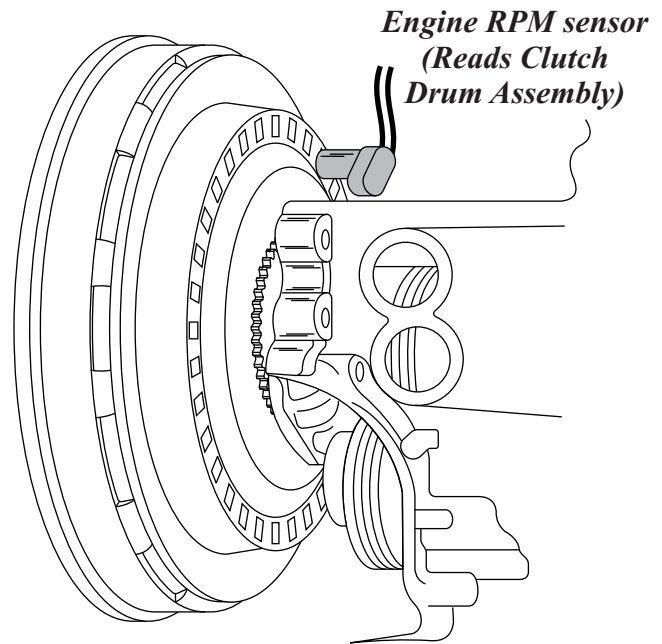

Copyright © ATSG 2012

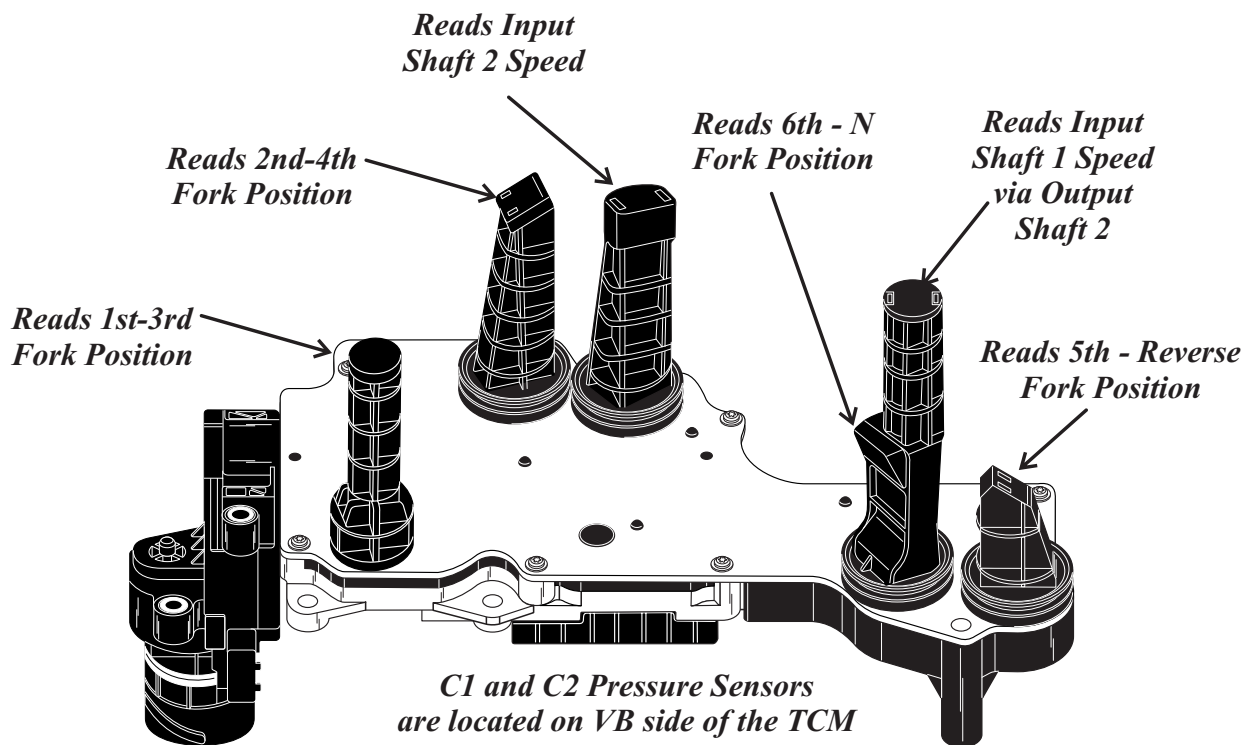

*The Temperature Sensor is built into TCM*

Copyright © ATSG 2012

Figure 32





TCM TERMINAL IDENTIFICATION AND LOCATION

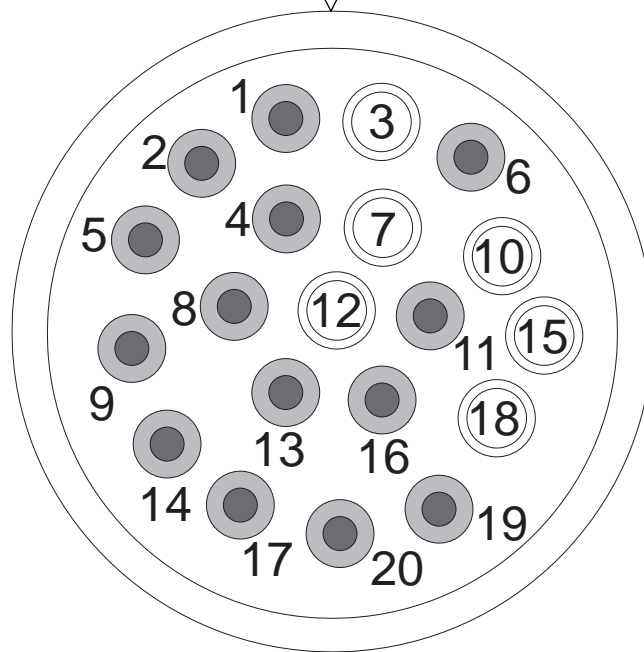
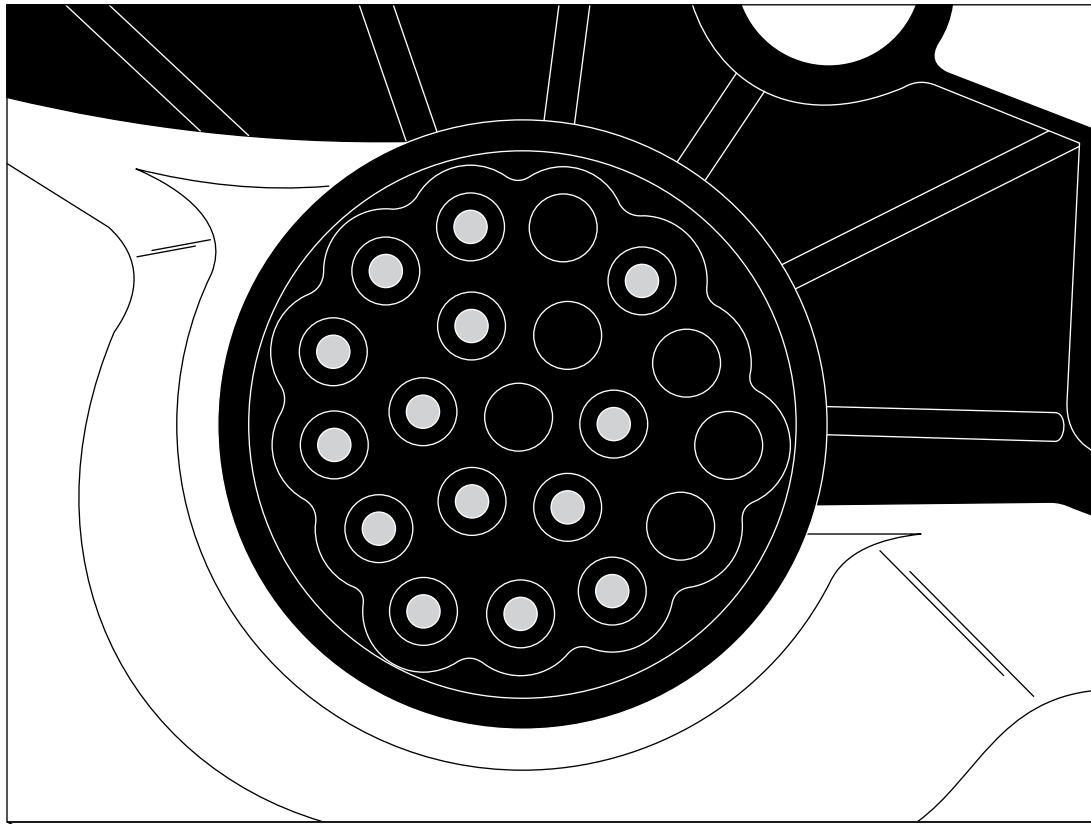

*TCM  
(Volvo 4/28)  
Connector A*

Copyright © ATSG 2012

Figure 33



# Technical Service Information

## TYPICAL VOLVO WIRING DIAGRAM

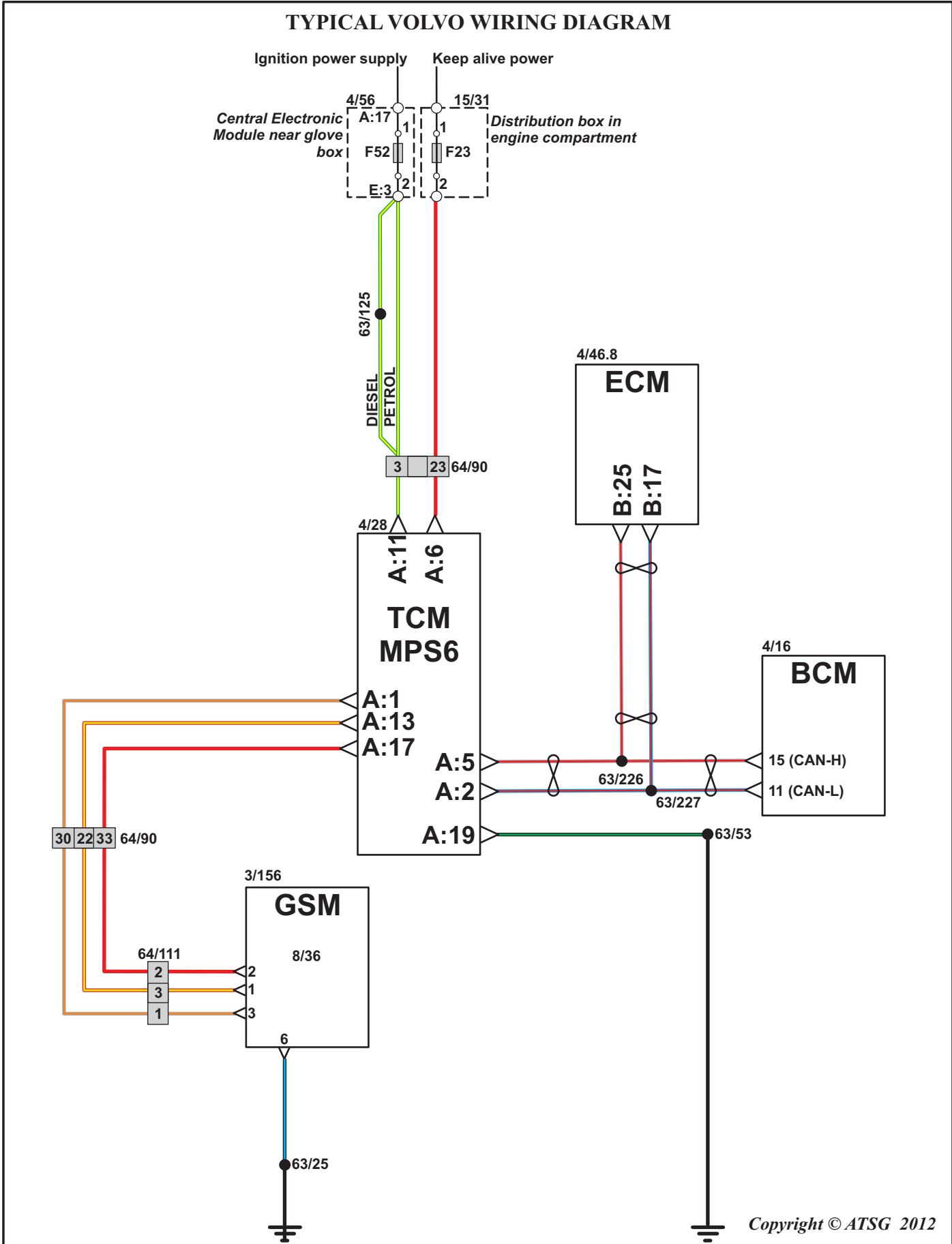

Copyright © ATSG 2012

Figure 34



Technical Service Information

**6DCT470 GETRAG TRANSMISSION**  
*W6DGA - SPS6*  
*Twin Clutch-Sportronic Shift Transmission*  
*(TC-SST)*

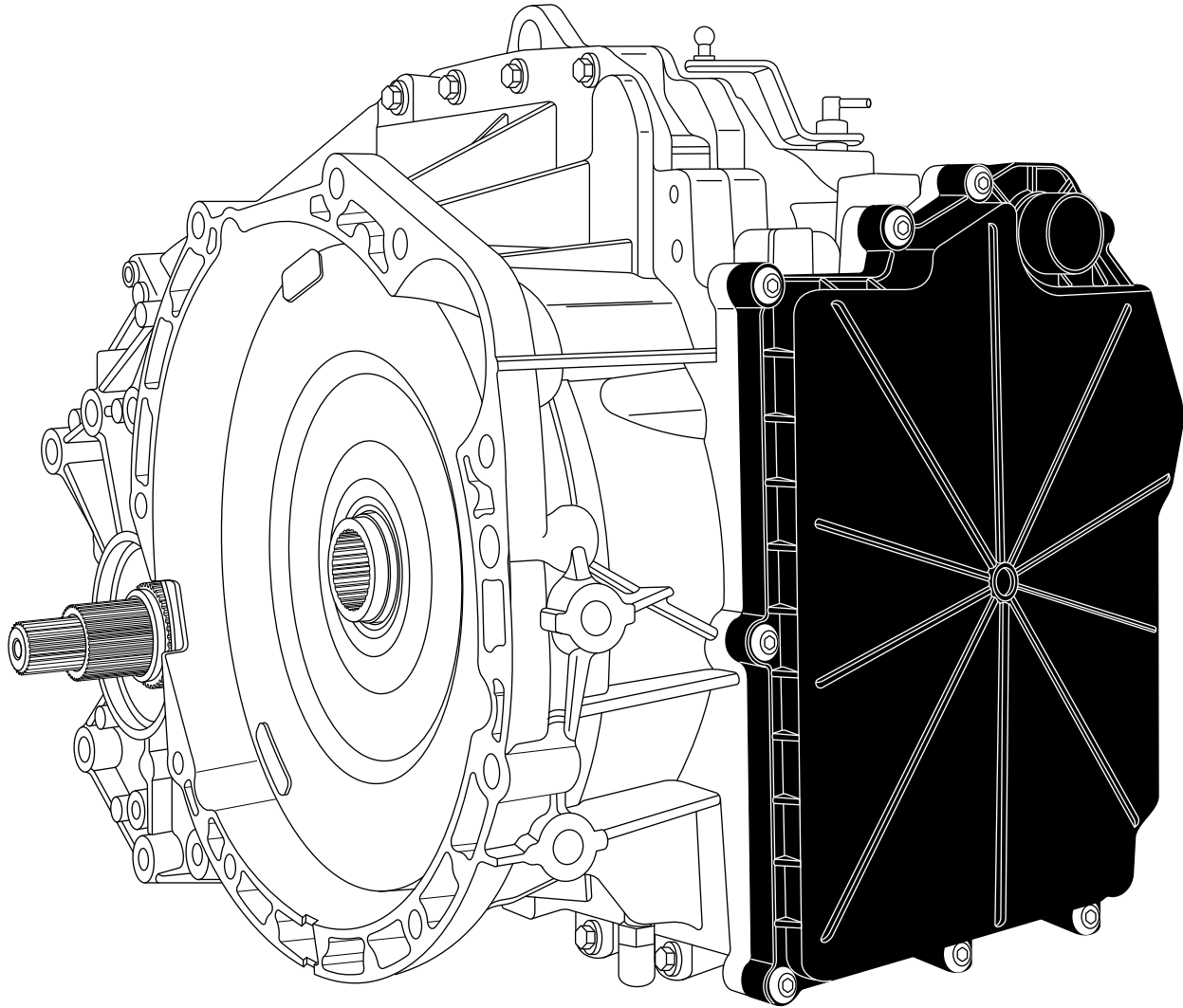

***Mitsubishi DCT470***

***Gear Ratios***

cX	(2010-present)
Galant Fortis	(2008-present)
Lancer	(2008-present)
Outlander	(2007-present)

1st.....	3.655
2nd.....	2.368
3rd.....	1.754
4th.....	1.322
5th.....	0.983
6th.....	0.731
Reverse.....	4.011
Final Gear Ratio.....	4.062

*At first glance this transmission looks very much the same as the Ford/Volvo DCT450 however, the DCT470 has a few significant differences which this portion of the handout will point out.*

Copyright © ATSG 2012



## Technical Service Information

### SHIFT LEVER CONSOLE

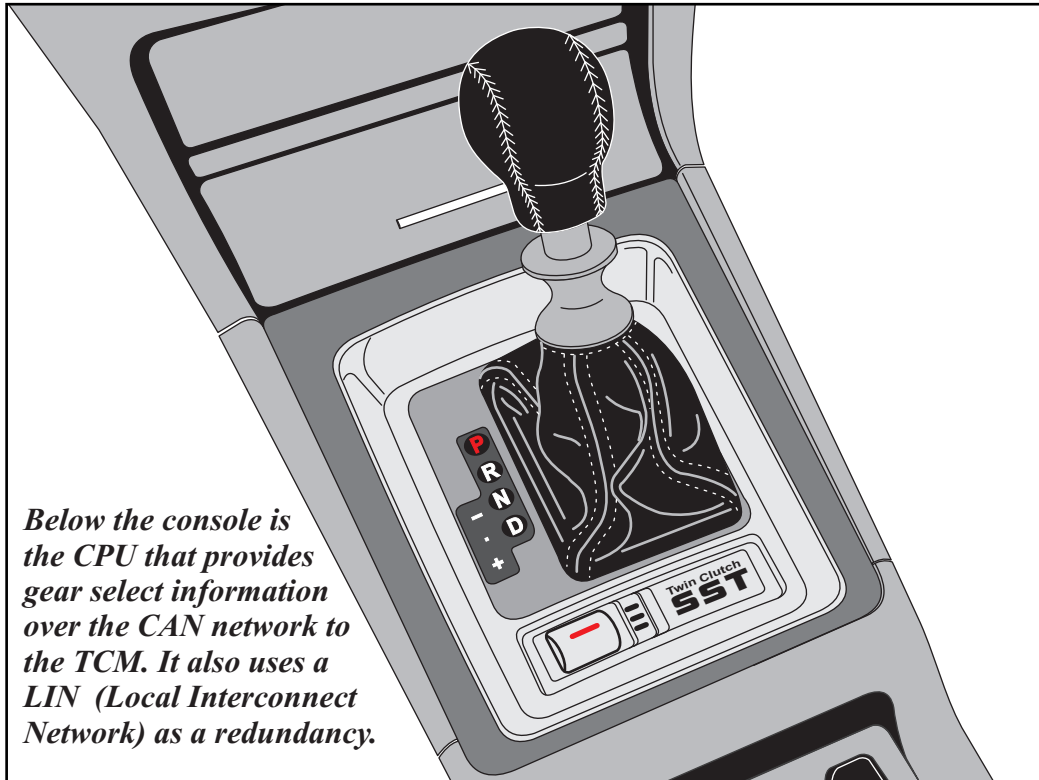

One of the main differences between the DCT450 and the DCT470 is that there is no transmission range sensor inside the transmission. The Shift Lever has below it a CPU which broadcasts gear select information over the CAN network to the TCM.

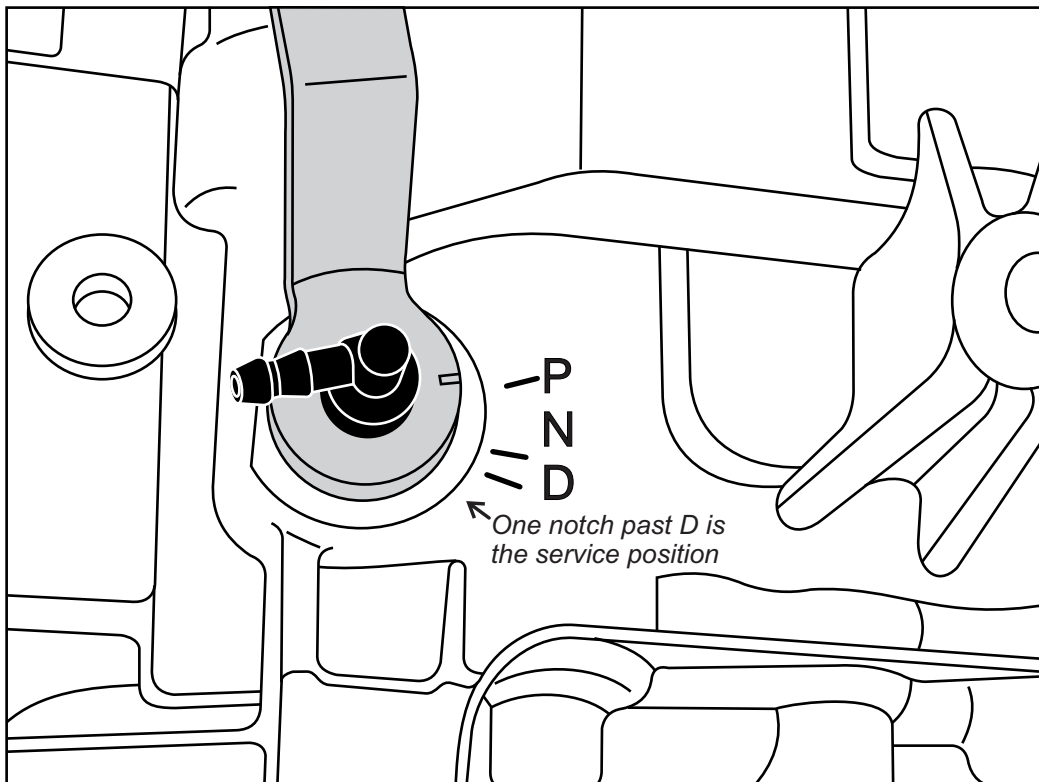

Copyright © ATSG 2012

Figure 35



# Technical Service Information

## TYPICAL MITSUBISHI WIRING DIAGRAM

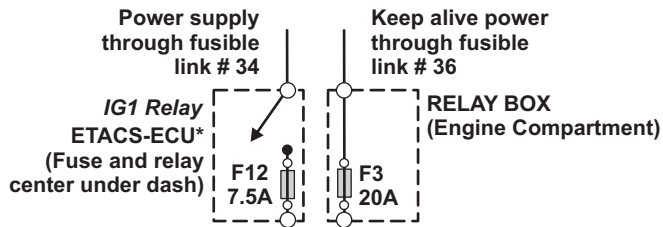

*\*ETACS-ECU has three main functions*

1. Gateway function
2. Coding function
3. Body electrical equipment control function

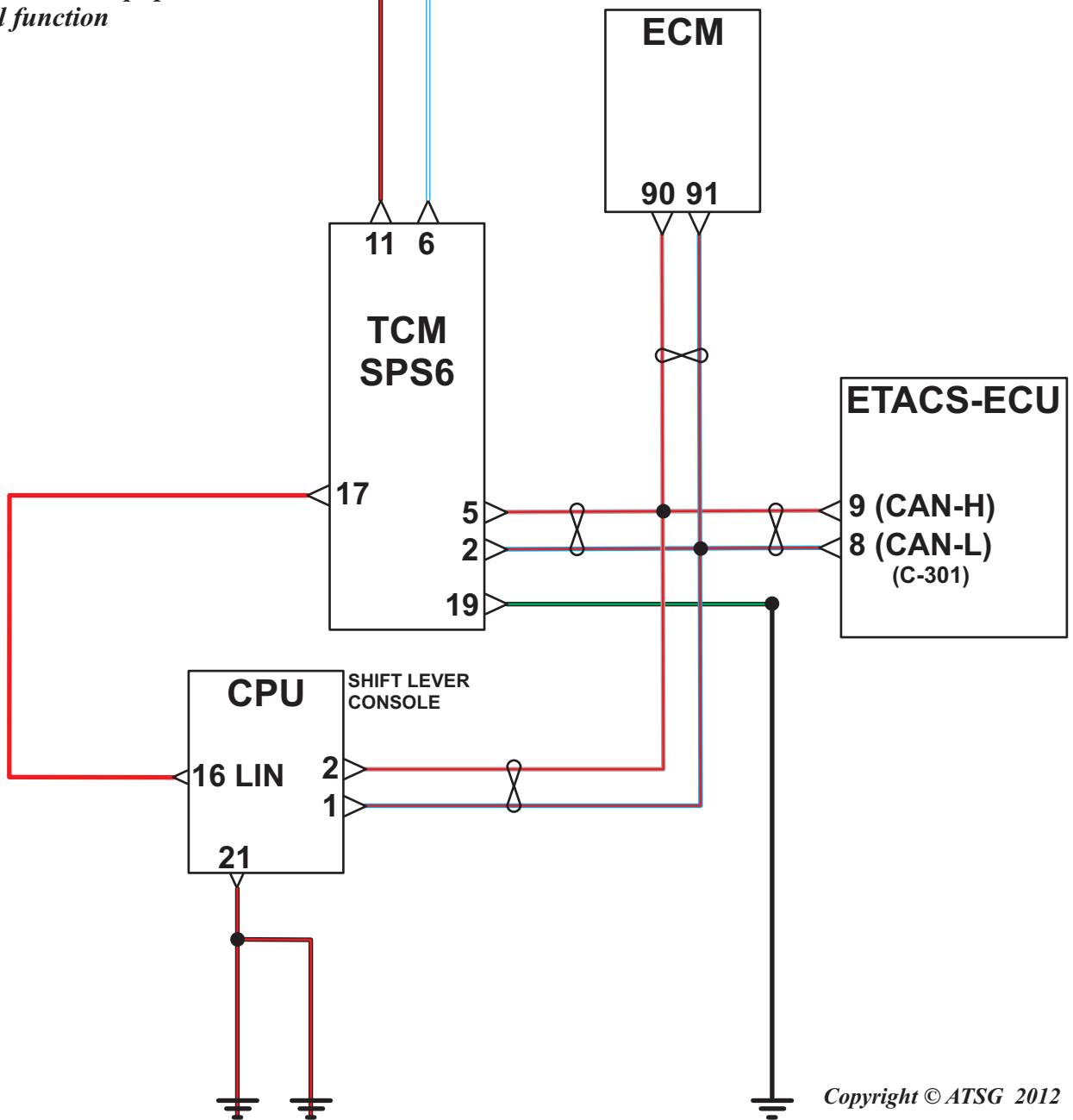
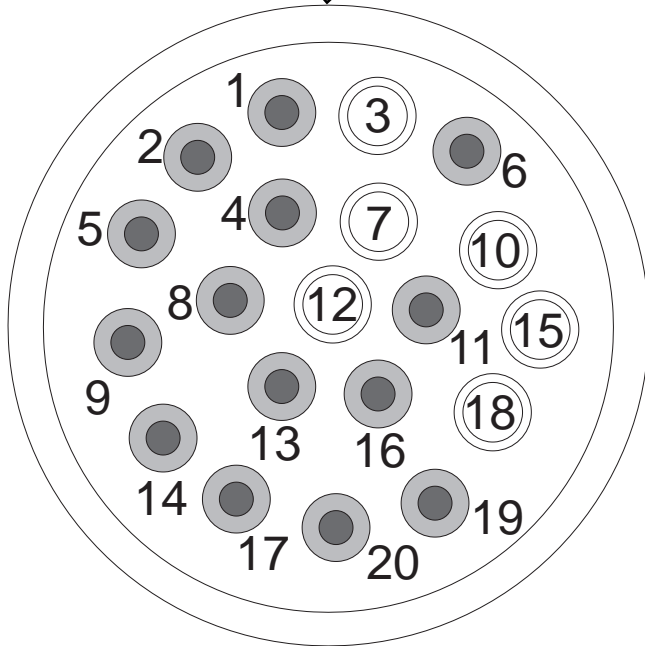
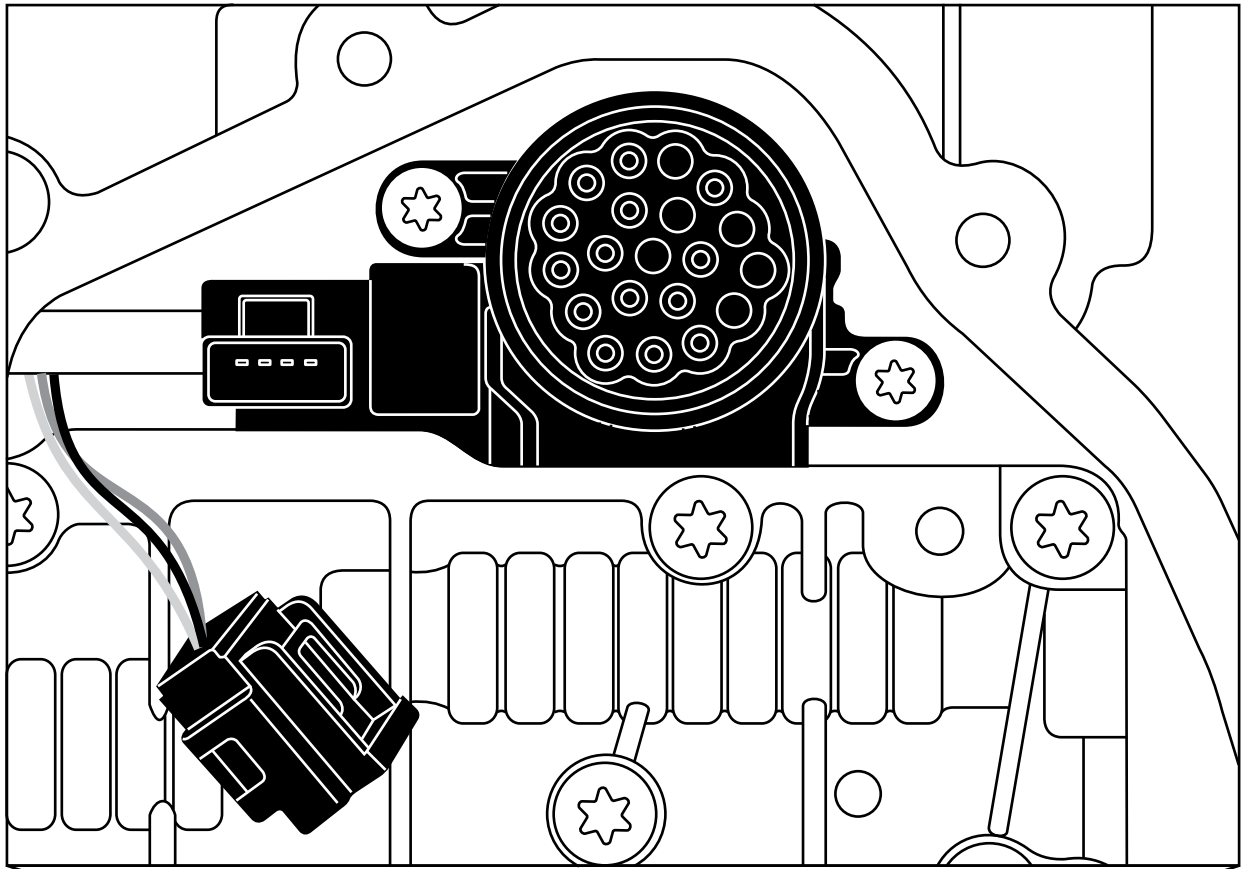

Figure 36

TCM CONNECTOR - NO TRS



*TCM  
Connector  
B-107*

Copyright © ATSG 2012

Figure 37





## Technical Service Information

### 6DCT470 GETRAG TRANSMISSION

#### Shaft To Case Orientation

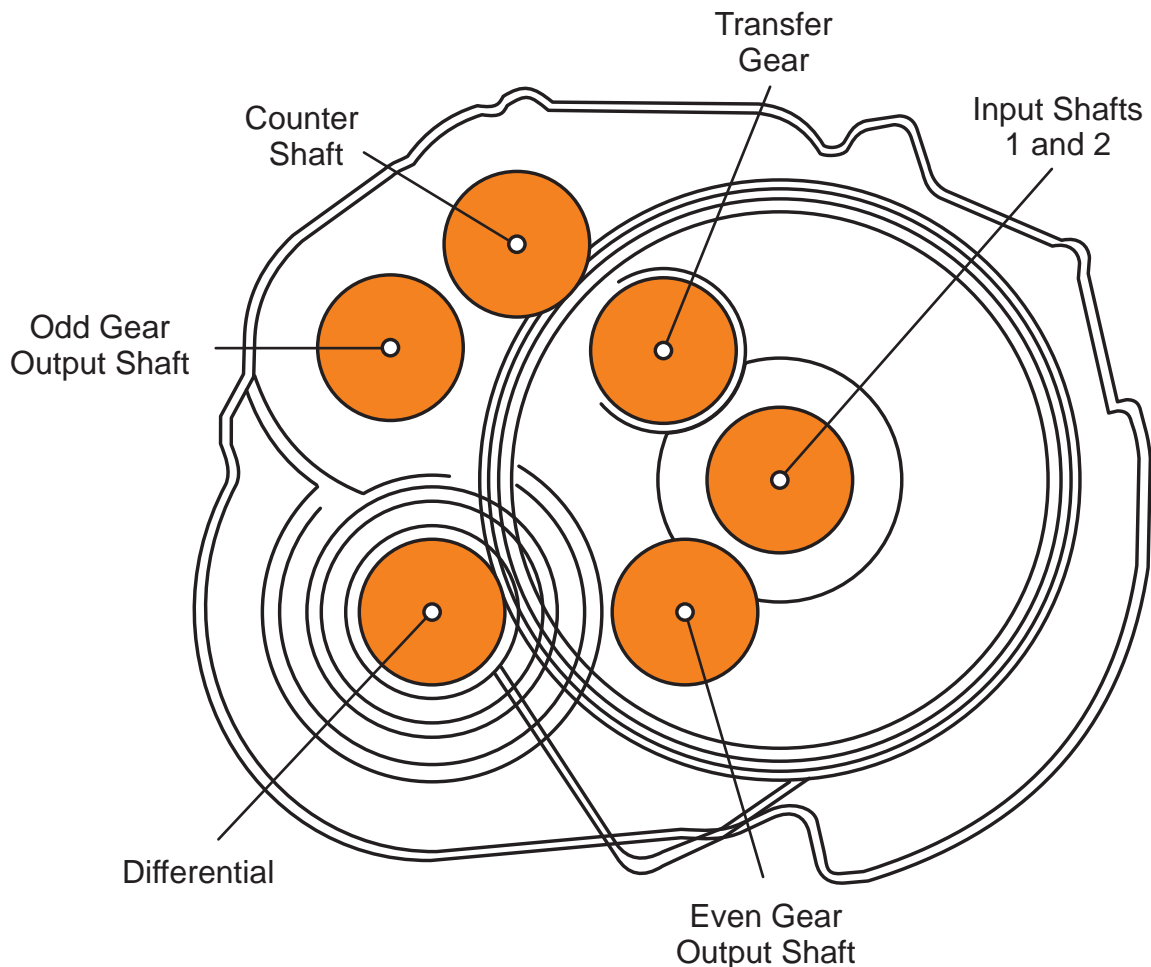

Another major departure from the DCT450 with this DCT470 is the internal shaft configuration. The DCT450 utilizes a double input shaft, two output shafts and an idler gear for reverse (Figure 7). This DCT470 utilizes a double input shaft, a transfer gear, a counter shaft, an odd gear output shaft and an even gear output shaft. Additionally, input shaft 1 (inner shaft) and clutch C1 with the DCT450 would drive the odd gears while input shaft 2 (outer shaft) and clutch C2 would drive even gears. With the DCT470 the opposite occurs. The outer input shaft and C1 clutch drives a transfer gear which provides torque input to the counter shaft and odd gear output shaft for all the odd gears. The inner input shaft and C2 clutch drives the even gear output shaft for all the even gears (Figure 39). As a result of these notable differences, differences can be observed with both case passages (Figure 42) and gearshift fork pairs (Figure 43).

Copyright © ATSG 2012

Figure 38



Technical Service Information

6DCT470 GETRAG TRANSMISSION

2x2 Shaft Layout

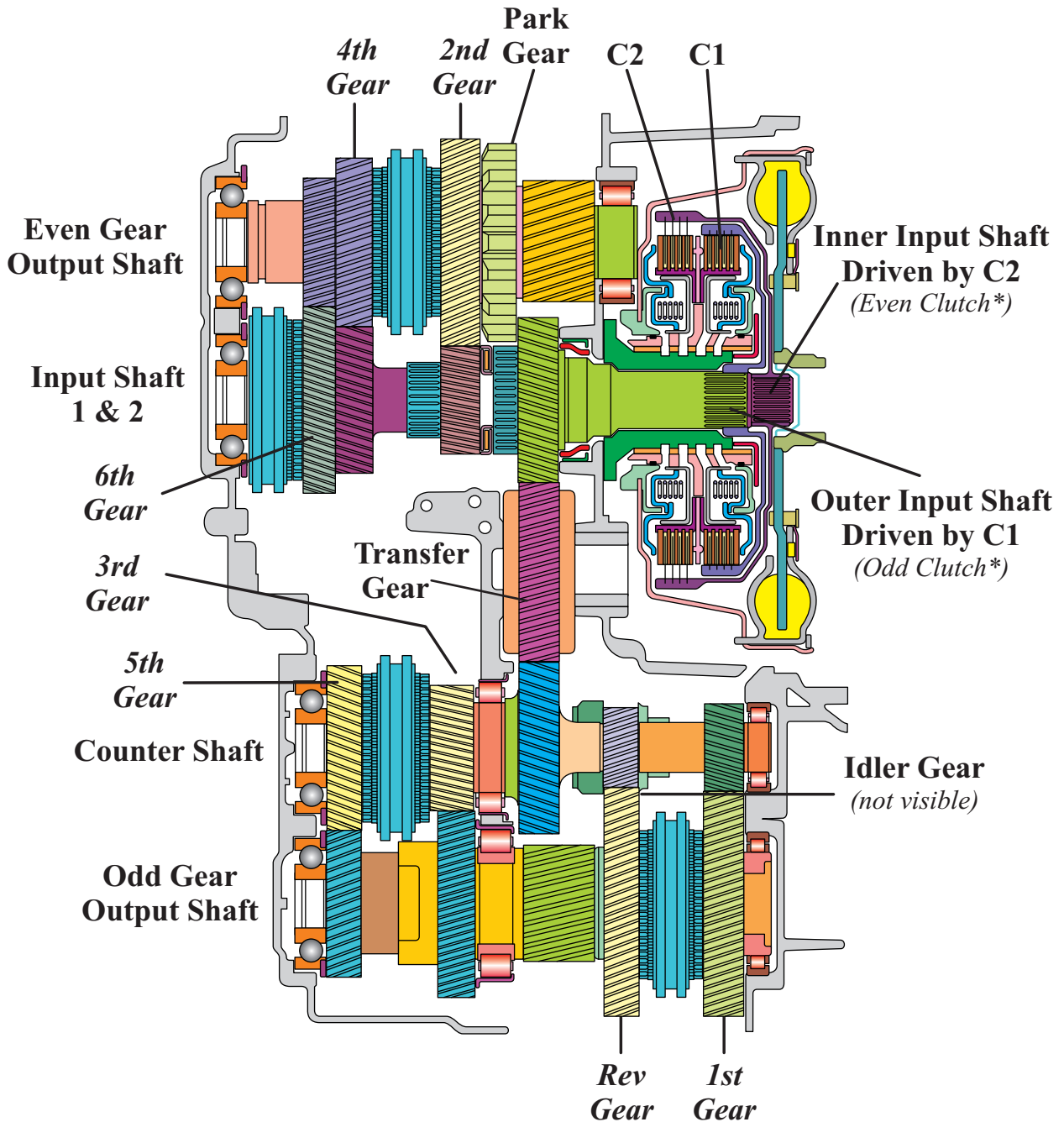

\*Note: The DCT470 has a completely different gear box configuration when compared to the DCT450 transmission which required swapping of clutch assemblies. The clutch closest to the engine is now the C1 clutch is the clutch closest to the transmission is the C2. As a result of these significant differences changes can be seen with case passages to accommodate the topography of the TCM's speed sensor and fork position sensors as seen in figure 42.

Copyright © ATSG 2012

Figure 39



Technical Service Information

**REMOVING THE CLUTCH HOUSING**

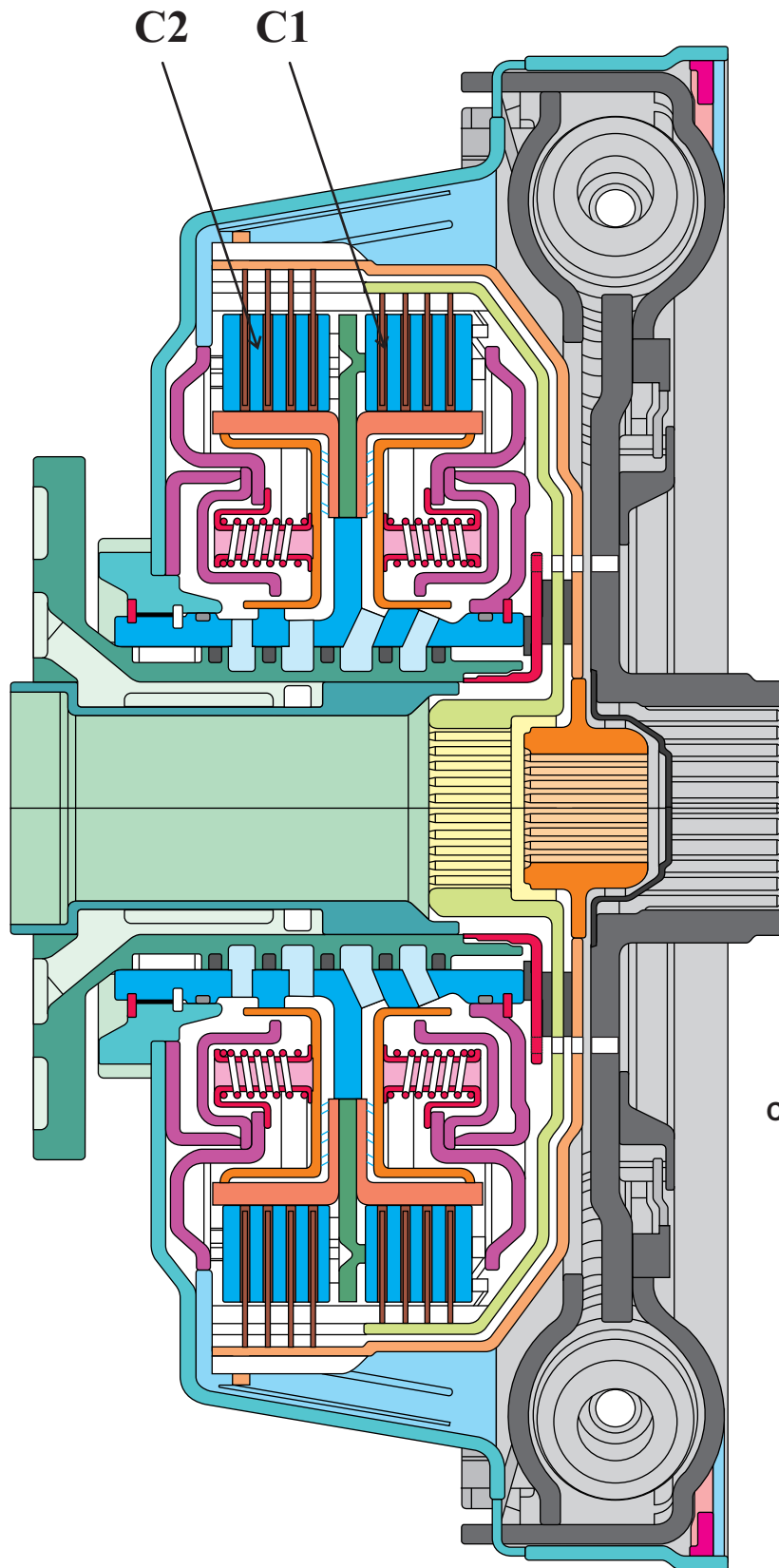

**DCT470**

**C1 = Clutch 1, Odd gears & reverse**

**C2 = Clutch 2, Even gears**

*When compared to the DCT450 (figure 15), the DCT470 swapped the use of the two clutch assemblies. The clutch assembly closest to the engine is the C1 odd gear clutch while the clutch assembly closest to the transmission is the C2 even gear clutch.*

*This swapping of the clutches was accomplished by providing a different routing of the oil circuits through the drum support.*

**DCT470 Drum Support  
Circuit identification**

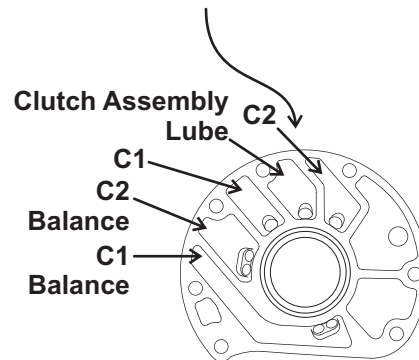
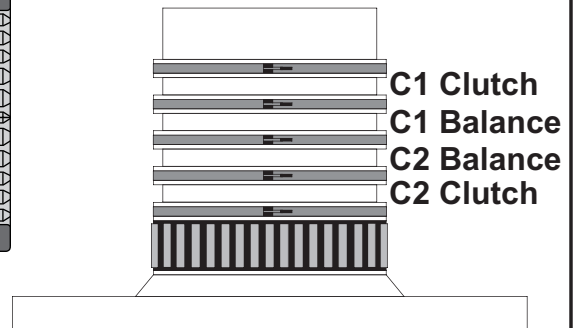

Copyright © ATSG 2012

Figure 40



## Technical Service Information

### BOLT ID FOR REMOVING THE VALVE BODY ASSEMBLY

*Ford/Volvo DCT450 does not have this exhaust passage making the valve body casting different. The spacer plate and channel plate (solenoid housing) are the same*

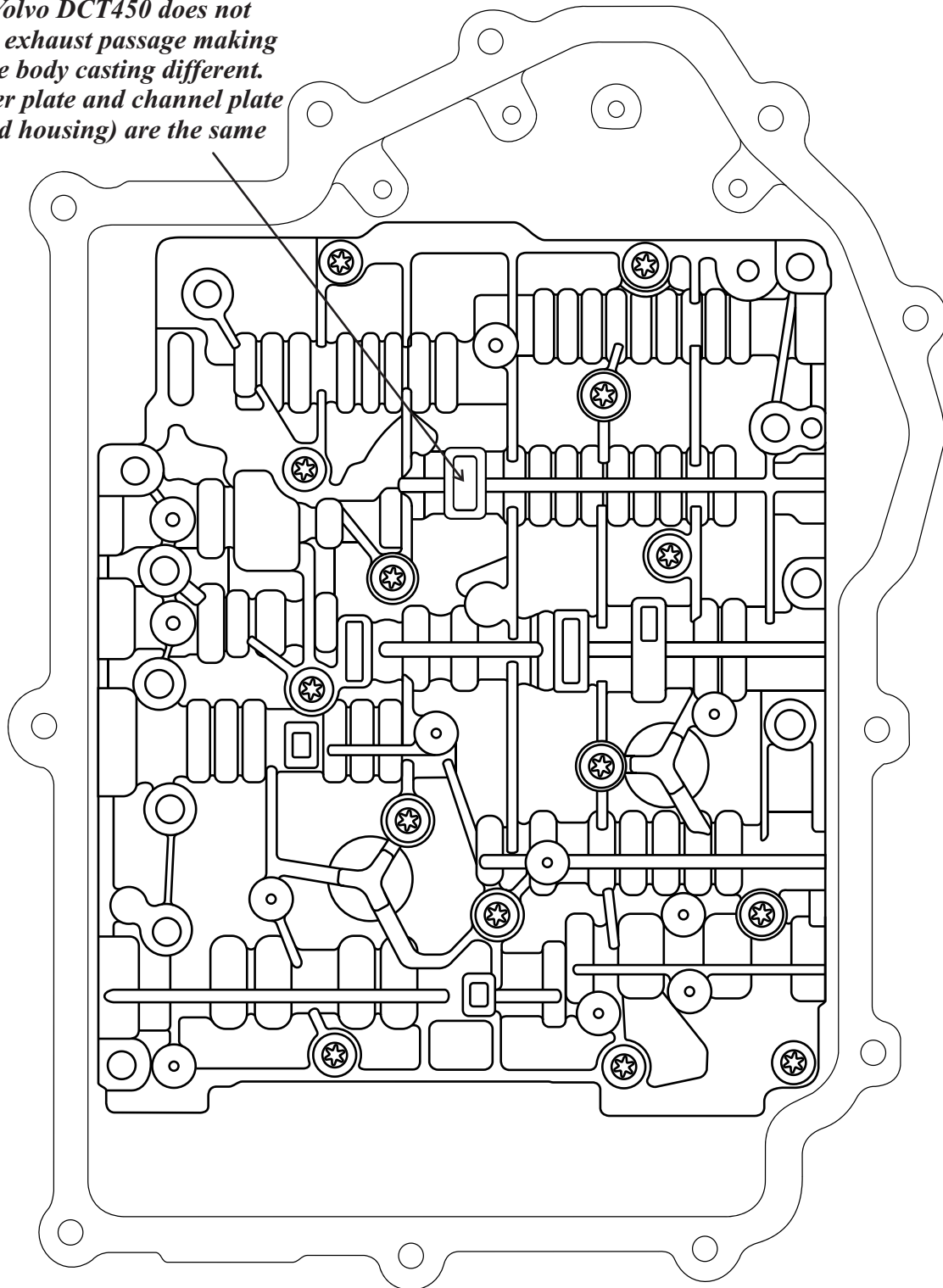

Remove the 11 valve body to case bolts identified by the X marks seen above (*same with the DCT450*). Once removed carefully pull the valve body far enough towards you to clear the sensors on the TCM that protrude deep into the case. There are long alignment pins mounted in the case to assist in this process. The locations of these pins are identified in figure 42.

Copyright © ATSG 2012

Figure 41



# Technical Service Information

## CASE PASSAGE IDENTIFICATION

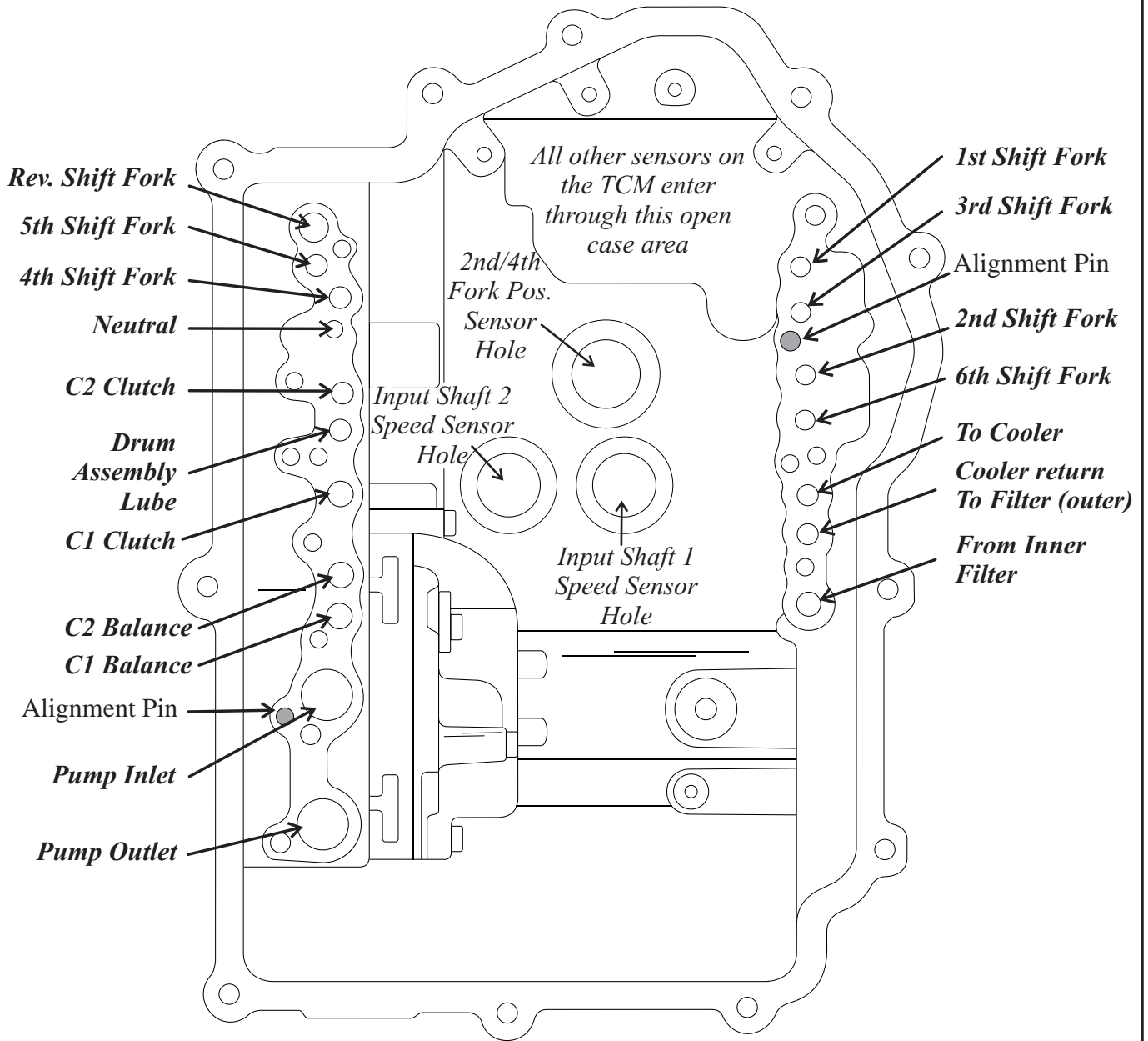

Copyright © ATSG 2012

Figure 42



# Technical Service Information

## DCT470 GEARSHIFT FORKS

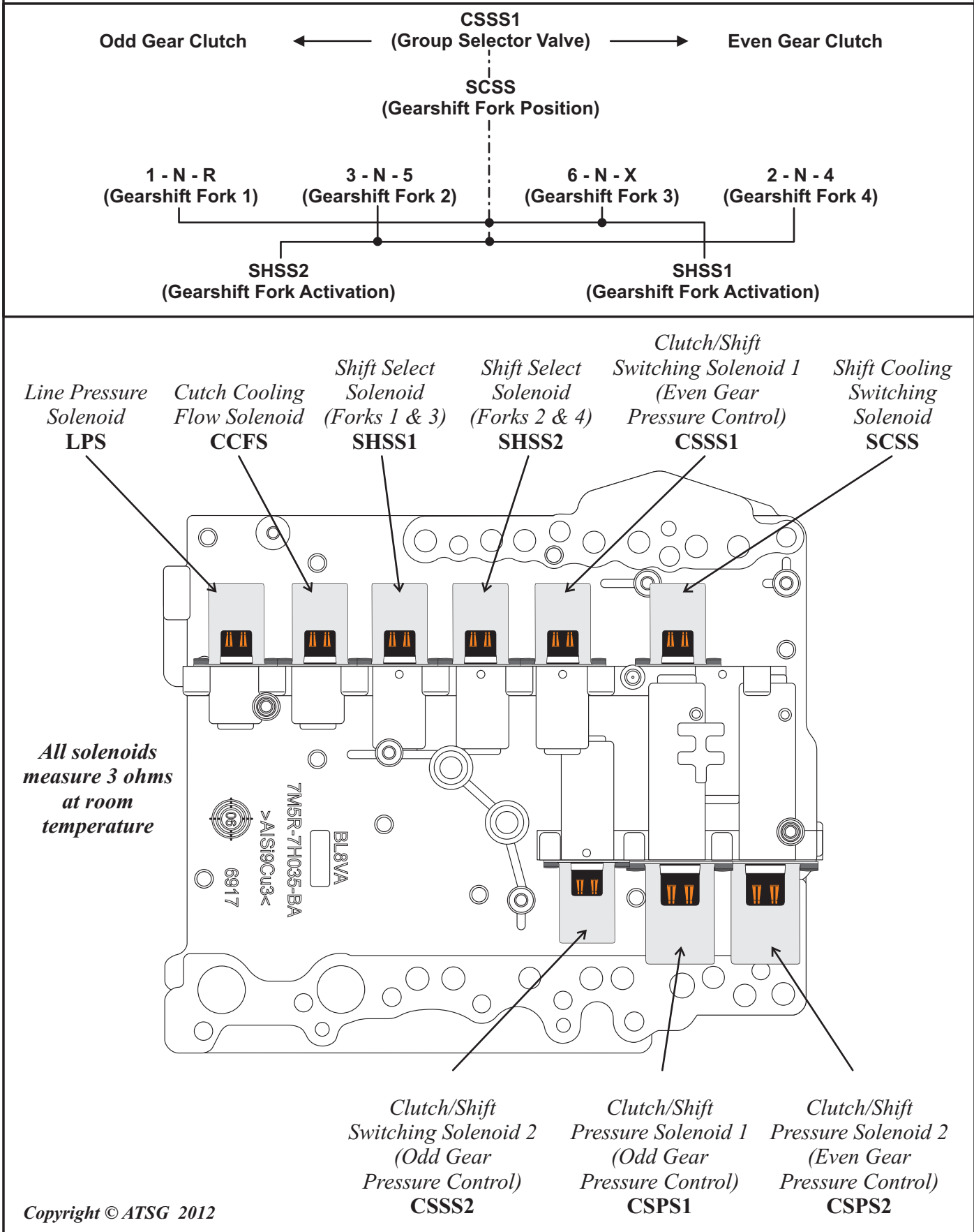

Figure 43





## Technical Service Information

### SOLENOID FUNCTION

- System pressure solenoid **LPS** (Line Pressure Solenoid) - Controls system pressure in the transmission by directing the hydraulic oil to clutch, shifting, cooling flow, and then returning the oil to the oil sump.
- Solenoid for cooling flow **CCFS** (Clutch Cooling Flow Solenoid) - Controls hydraulic oil for cooling of clutches.
- Multiplex solenoid **SCSS** (Shift Cooling Switching Solenoid) - Controls position of gearshift forks as well as cooling of clutch.
- Multiplex solenoid **CSSS1** (Clutch Shift Switching Solenoid) - Leads the pressure between even clutch and shifting, activates even gears as well as controls cooling flow for clutches.
- Multiplex solenoid **CSSS2** (Clutch Shift Switching Solenoid) - Leads the pressure between odd clutch and shifting, controls cooling flow for clutches and can turn off the valve for dumping clutch pressure **CPCUT** to regain clutch pressure.
- Solenoid for clutch pressure Odd gears **CSPS1** (Clutch Shift Pressure Solenoid) - Controls hydraulic pressure for Odd clutch or shifting.
- Solenoid for clutch pressure even gears **CSPS2** (Clutch Shift Pressure Solenoid) - Controls hydraulic pressure for even clutch or shifting.
- Valve for dumping clutch pressure **CPCUT** (Clutch Pressure Cut) - Safety valve that controls pressure-dumping in the hydraulic system.
- Shift solenoid **SHSS1** (Shift Select Solenoid) - Controls shifting for gearshift fork 1 and 3.
- Shift solenoid **SHSS2** (Shift Select Solenoid) - Controls shifting for gearshift fork 2 and 4.

#### Closed/open solenoids

The solenoids that are closed/open are the CSSS1, CSSS2, SCSS, SHSS1 and SHSS2. These have only 2 positions, completely closed or fully open. The solenoids control valves that lead the hydraulic pressure to the desired system. Depending on system pressure and temperature, the Transmission control module (TCM) calculates the current that needs to be triggered to respective solenoid. The triggered current to the solenoids is not returned, which means that diagnostics of the solenoids is limited to only being able to see if they are off or on.

#### Linear solenoids

Linear solenoids (CCFS, LPS, CPS1 and CPS2) are controlled by a pulse-width modulated (PWM) current to enable linear or gradual control of the hydraulic pressure. The pulse-width modulated current induces a magnetic field that moves a core inside the solenoid. The solenoid can control the pressure by gradually opening or closing valves. The triggered current to the solenoids is returned to Transmission control module (TCM), which means that more advanced diagnosis is possible.



# Technical Service Information

## DCT470 COMPLETE VALVE BODY AND SOLENOID IDENTIFICATION

**CSPS solenoids  
(2 Required)**

7070 TM07/226  
7M5R-7G136-CA

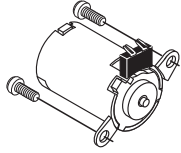

**All other solenoids  
(5 Required)**

8270 TM07/234  
7M5R-7G484-DA

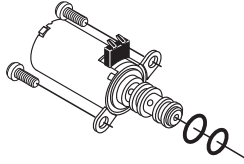

**LPS & CCFS solenoids  
(2 Required)**

8270 TM07/296  
7M5R-7G383-DA

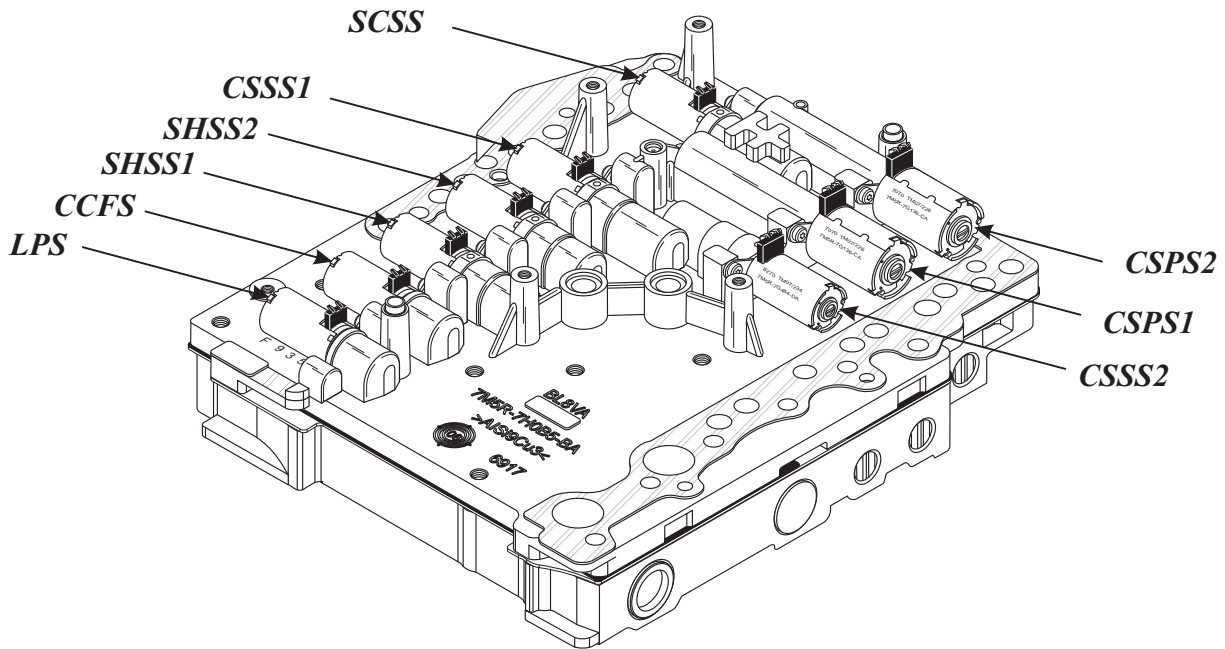
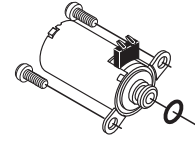

*The Line Pressure Solenoid not listed in the chart is turned on to drop line pressure throughout various shift sequences as needed for smooth shift transitions.*

*The solenoid sequence listed below has been determined via a hydraulic schematic produced by ATSG.*

Gearshift Patterns	Activated Solenoids						
	SCSS	SHSS1	SHSS2	CSSS1	CSSS2	CSPP1	CSPP2
Engage 1	On	On	Off	On	Off	High	X
Engage 2	Off	Off	On	Off	On	X	High
Engage 3	Off	Off	On	On	Off	High	X
Engage 4	On	Off	On	Off	On	X	High
Engage 5	On	Off	On	On	Off	High	X
Engage 6	Off	On	Off	Off	On	X	High
Engage R	Off	On	Off	On	Off	High	X
Park/Neutral	On	On	Off	Off	On	X	High

Copyright © ATSG 2012

Figure 44



# Technical Service Information

## DCT470 VALVE BODY ASSEMBLY

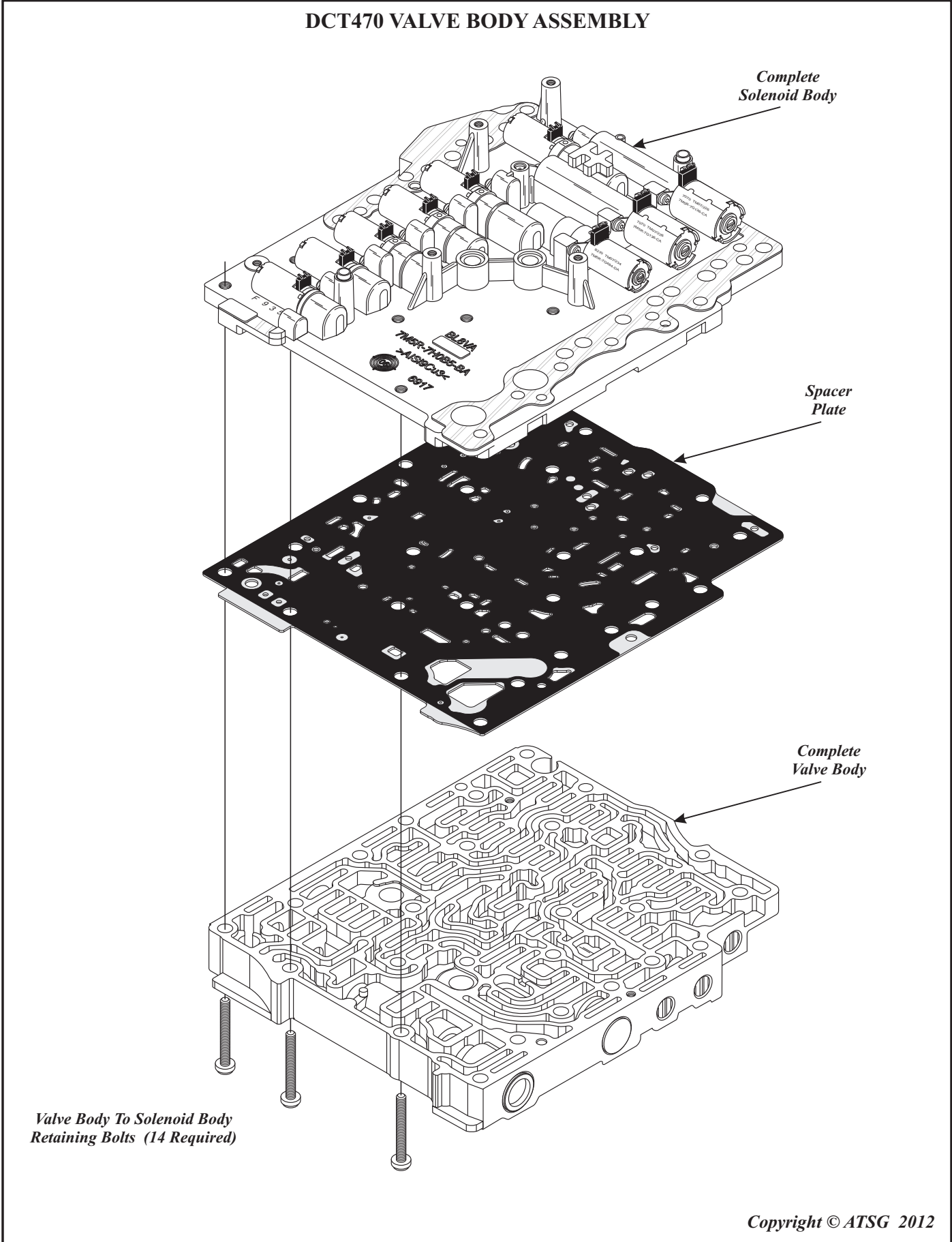

Copyright © ATSG 2012

Figure 45



# Technical Service Information

## DCT470 SOLENOID BODY EXPLODED VIEW

<b>SOLENOID BODY SPRING SPECIFICATIONS</b>	
SPRING NO. 314 & 319	SPRING NO. 316
Free Length = .260"	Free Length = .289"
Spring Diameter = .446"	Spring Diameter = .199"
Wire Diameter = .046"	Wire Diameter = .018"
Approx Coils = 4 (NONE)	Approx Coils = 6 (NONE)

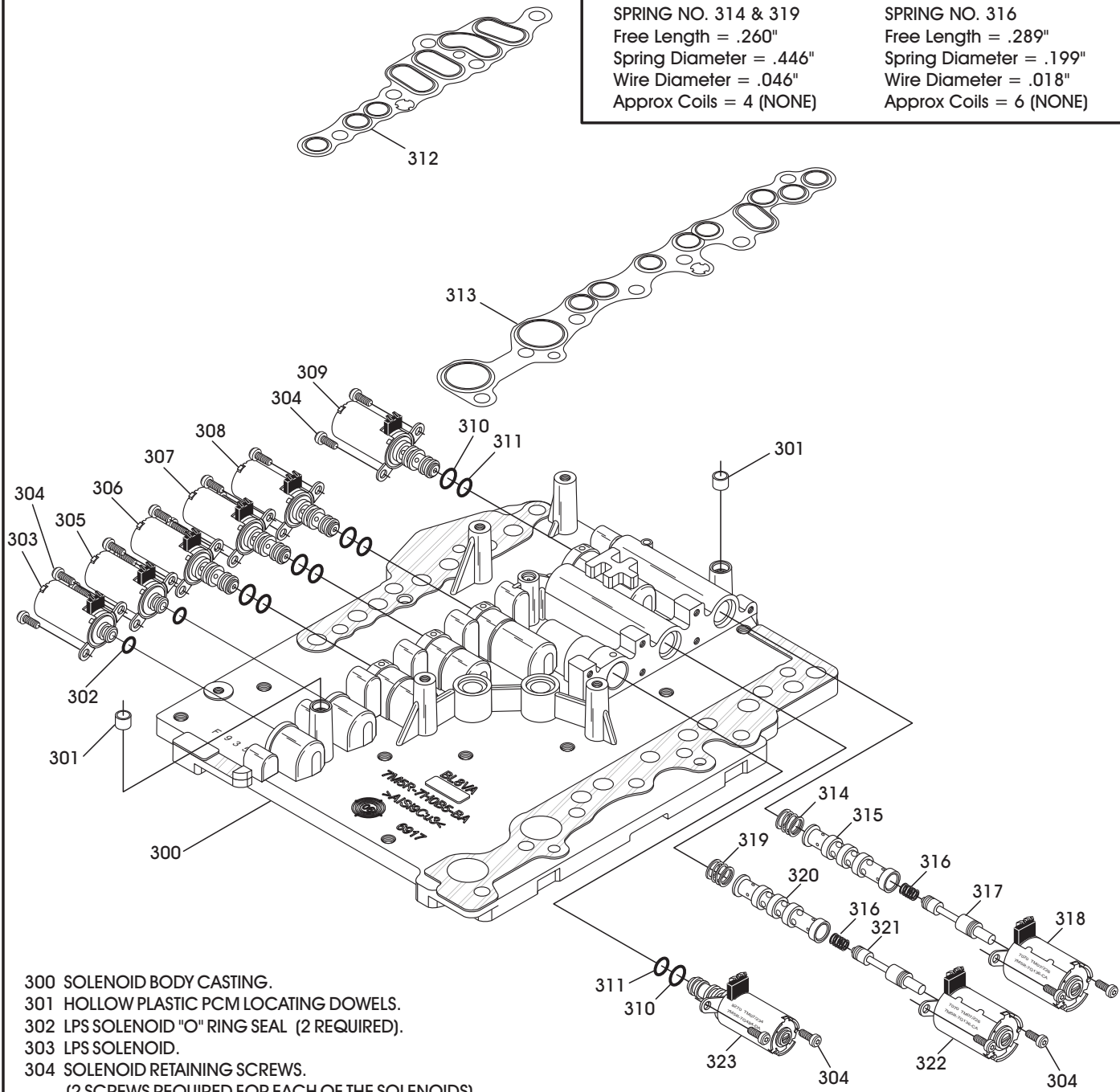

- 300 SOLENOID BODY CASTING.
- 301 HOLLOW PLASTIC PCM LOCATING DOWELS.
- 302 LPS SOLENOID "O" RING SEAL (2 REQUIRED).
- 303 LPS SOLENOID.
- 304 SOLENOID RETAINING SCREWS.  
(2 SCREWS REQUIRED FOR EACH OF THE SOLENOIDS)
- 305 CCF5 SOLENOID.
- 306 SHSS1 SOLENOID.
- 307 SHSS2 2 SOLENOID.
- 308 C5SS1 SOLENOID.
- 309 SCSS SOLENOID.
- 310 TYPE 2 SOLENOID LARGE "O" RING SEAL.
- 311 TYPE 2 SOLENOID SMALL "O" RING SEAL.  
(LARGE AND SMALL SEAL REQUIRED FOR EACH TYPE 2 SOL)
- 312 SHORT STEEL "RIBBED" VALVE BODY TO CASE GASKET.
- 313 LONG STEEL "RIBBED" VALVE BODY TO CASE GASKET.

- 314 C5PS2 SOLENOID SLEEVE SPRING.
- 315 C5PS2 SOLENOID SLEEVE.
- 316 C5PS1 & 2 SOLENOID VALVE SPRING.
- 317 C5PS2 SOLENOID VALVE.
- 318 C5PS2 SOLENOID.
- 319 C5PS1 SOLENOID SLEEVE SPRING.
- 320 C5PS1 SOLENOID SLEEVE.
- 321 C5PS1 SOLENOID VALVE.
- 322 C5PS1 SOLENOID.
- 323 C5SS2 SOLENOID.

Copyright © ATSG 2012

Figure 46



# Technical Service Information

## DCT470 LOWER VALVE BODY RETAINER AND SMALL PARTS LOCATIONS

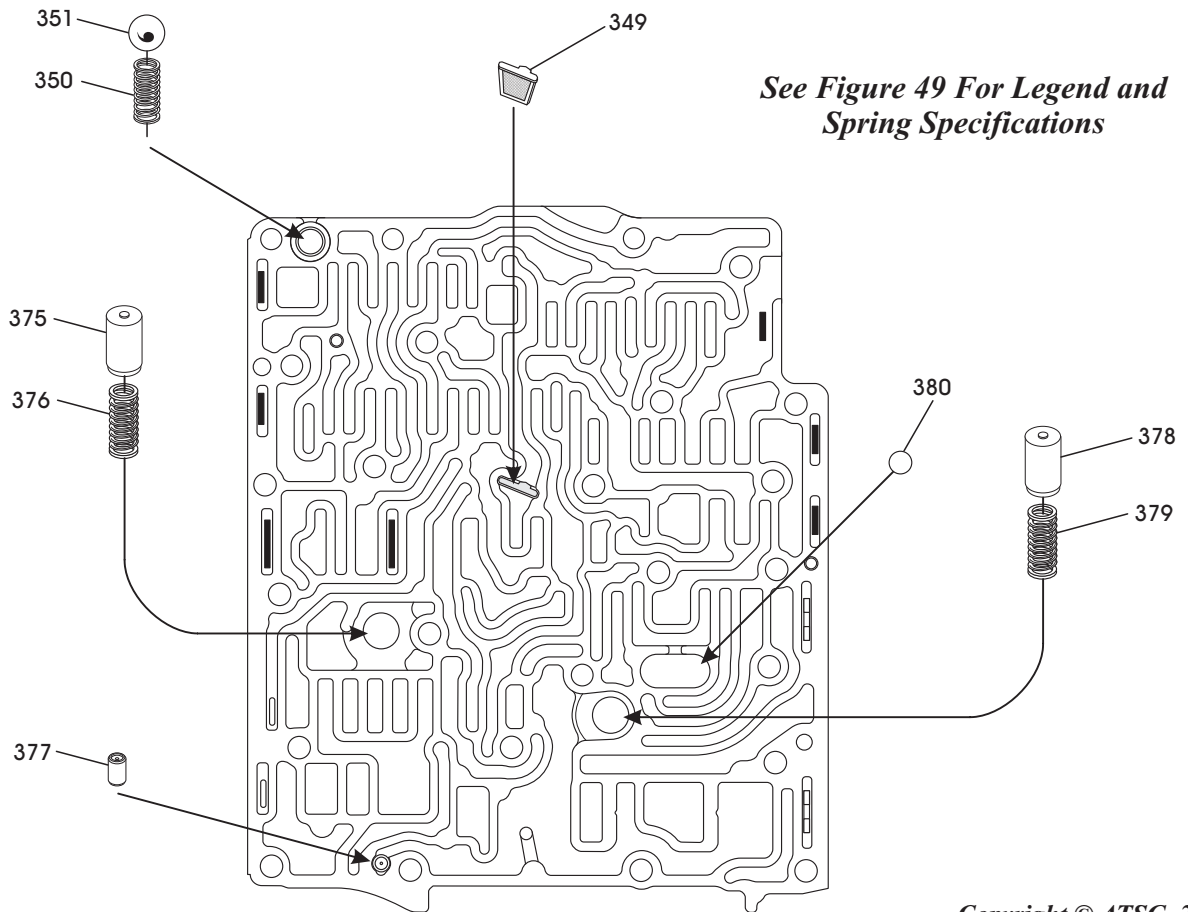
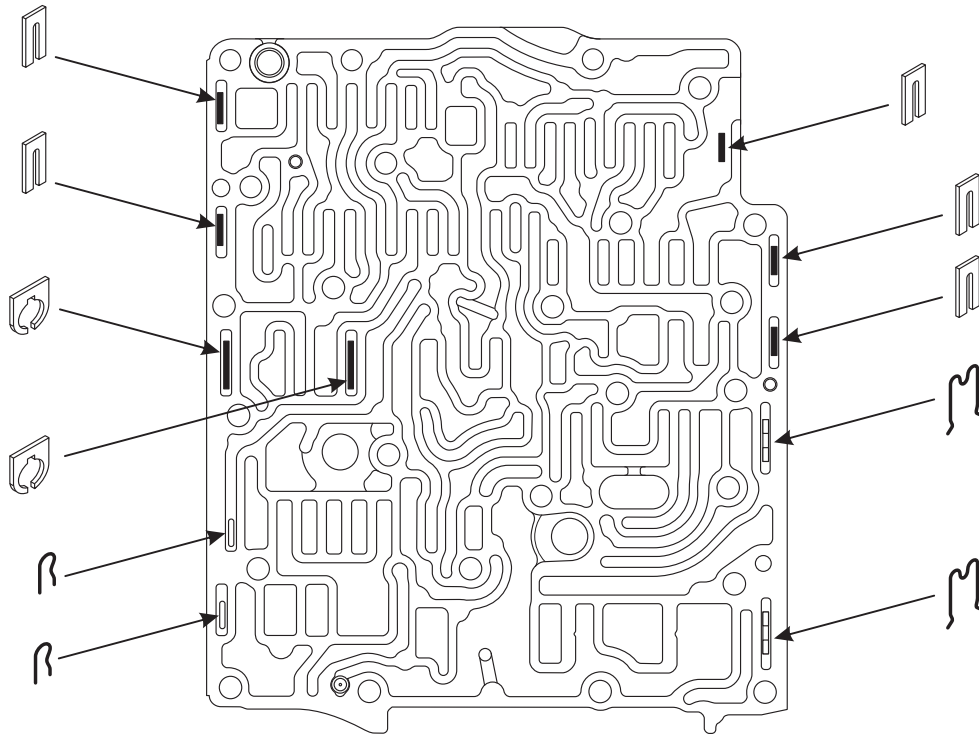

Copyright © ATSG 2012

Figure 47





# Technical Service Information

## DCT470 MAIN VALVE BODY, EXPLODED VIEW

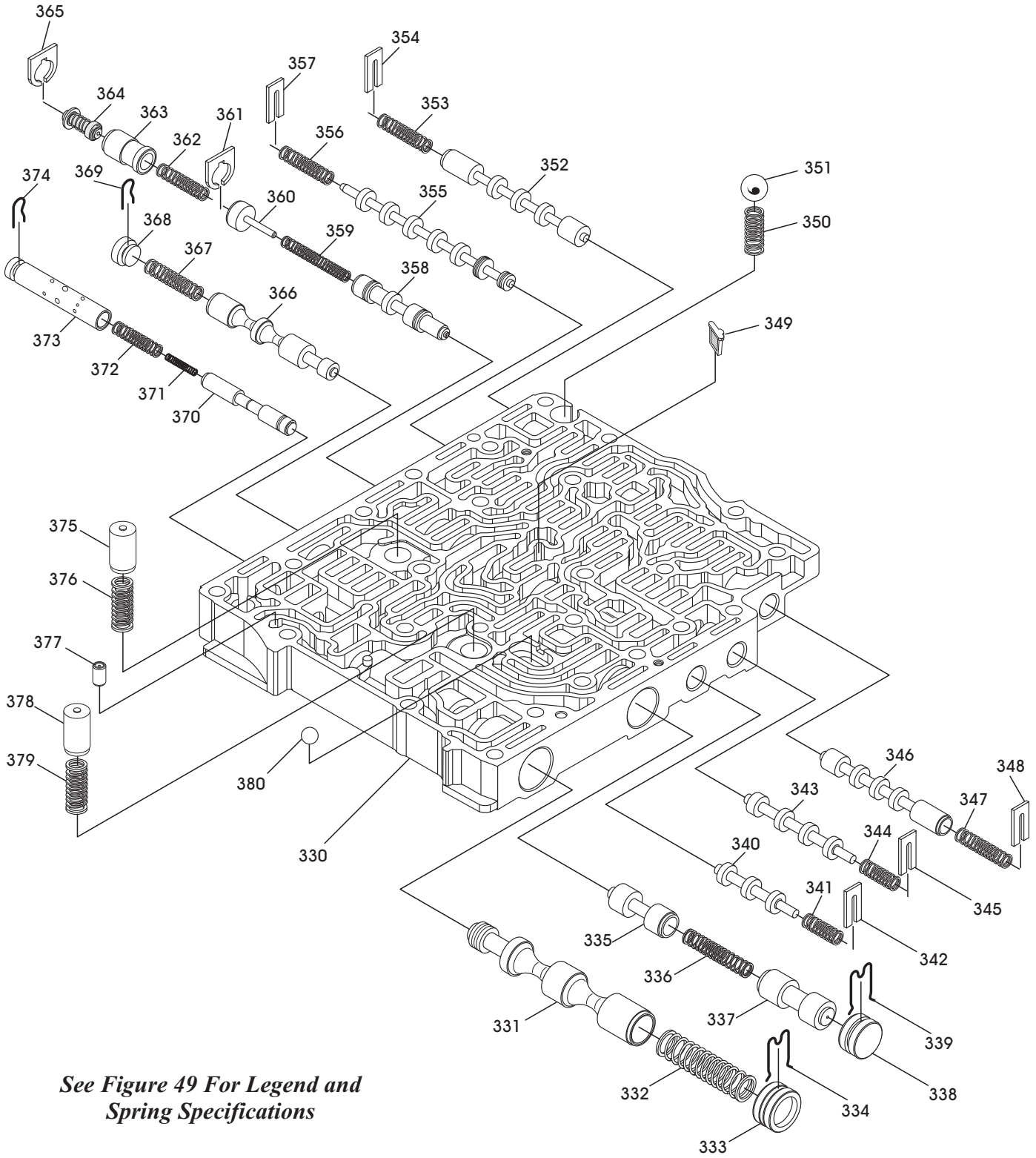

*See Figure 49 For Legend and Spring Specifications*

Copyright © ATSG 2012

Figure 48



# Technical Service Information

## DCT470 MAIN VALVE BODY LEGEND

- |  |   |
|--|---|
| 330 MAIN VALVE BODY CASTING.                             | 358 PRESSURE CUT SPOOL VALVE.                               |
| 331 PRIMARY PRESSURE REGULATOR VALVE.                    | 359 PRESSURE CUT SPOOL VALVE SPRING.                        |
| 332 PRIMARY PRESSURE REGULATOR VALVE SPRING.             | 360 PRESSURE CUT SPOOL VALVE BORE PLUG.                     |
| 333 PRIMARY PRESSURE REGULATOR VALVE BORE PLUG.          | 361 BORE PLUG RETAINER.                                     |
| 334 PRIMARY PRESSURE REGULATOR VALVE BORE PLUG RETAINER. | 362 THERMAL VALVE SPRING.                                   |
| 335 2-4/3-5 SWITCHING VALVE .                            | 363 THERMAL REACTION VALVE.                                 |
| 336 SWITCHING VALVE SPRING.                              | 364 THERMAL BY-PASS VALVE.                                  |
| 337 1-R/6-N SWITCHING VALVE.                             | 365 THERMAL BY-PASS VALVE RETAINER.                         |
| 338 SWITCHING VALVE BORE PLUG.                           | 366 CLUTCH COOLING SWITCHING VALVE.                         |
| 339 SWITCHING VALVE BORE PLUG RETAINER.                  | 367 CLUTCH COOLING SWITCHING VALVE SPRING.                  |
| 340 ODD CLUTCH/SHIFT SWITCHING VALVE.                    | 368 CLUTCH COOLING SWITCHING VALVE BORE PLUG.               |
| 341 ODD CLUTCH CONTROL VALVE SPRING.                     | 369 CLUTCH COOLING SWITCHING VALVE BORE PLUG RETAINER.      |
| 342 ODD CLUTCH CONTROL VALVE RETAINER.                   | 370 CLUTCH COOLING CONTROL VALVE.                           |
| 343 EVEN CLUTCH/SHIFT SWITCHING VALVE.                   | 371 CLUTCH COOLING CONTROL VALVE INNER SPRING.              |
| 344 EVEN CLUTCH CONTROL VALVE SPRING.                    | 372 CLUTCH COOLING CONTROL VALVE OUTER SPRING.              |
| 345 EVEN CLUTCH CONTROL VALVE RETAINER.                  | 373 CLUTCH COOLING CONTROL VALVE SLEEVE ASSEMBLY.           |
| 346 EVEN GEAR ACTUATOR VALVE.                            | 374 CLUTCH COOLING CONTROL VALVE RETAINER.                  |
| 347 EVEN GEAR ACTUATOR VALVE SPRING.                     | 375 LUBE PRESSURE RELIEF VALVE.                             |
| 348 EVEN GEAR ACTUATOR VALVE RETAINER.                   | 376 LUBE PRESSURE RELIEF VALVE SPRING.                      |
| 349 CSPTS 1 & 2, SCSS SOLENOID SCREEN.                   | 377 PLASTIC ORIFICE ASSEMBLY (.043" DIAMETER).              |
| 350 COMBINED DRAIN BALL SPRING.                          | 378 LINE PRESSURE RELIEF VALVE.                             |
| 351 COMBINED DRAIN BALL (STEEL), 12 MM (.472") DIAMETER. | 379 LINE PRESSURE RELIEF VALVE SPRING.                      |
| 352 ODD GEAR ACTUATOR VALVE.                             | 380 ODD EVEN SHUTTLE BALL (WHITE PLASTIC - .375" DIAMETER). |
| 353 ODD GEAR ACTUATOR VALVE SPRING.                      |   |
| 354 ODD GEAR ACTUATOR VALVE RETAINER.                    |   |
| 355 GROUP SELECTOR VALVE.                                |   |
| 356 GROUP SELECTOR VALVE SPRING.                         |   |
| 357 GROUP SELECTOR VALVE RETAINER.                       |   |

### MAIN VALVE BODY SPRING SPECIFICATIONS

<b>SPRING NUMBER 332</b> Free Length = 2.122" Spring Diameter = .474" Wire Diameter = .047" Approx Coils = 13 (NONE)	<b>SPRING NUMBER 336</b> Free Length = 1.720" Spring Diameter = .285" Wire Diameter = .032" Approx Coils = 17 (NONE)	<b>SPRING NUMBER 341</b> Free Length = 1.080" Spring Diameter = .299" Wire Diameter = .032" Approx Coils = 10 (NONE)	<b>SPRING NUMBER 344</b> Free Length = 1.080" Spring Diameter = .299" Wire Diameter = .032" Approx Coils = 10 (NONE)
<b>SPRING NUMBER 347</b> Free Length = 1.374" Spring Diameter = .284" Wire Diameter = .026" Approx Coils = 13 (NONE)	<b>SPRING NO. 353</b> Free Length = 1.385" Spring Diameter = .284" Wire Diameter = .026" Approx Coils = 13 (NONE)	<b>SPRING NO. 356</b> Free Length = 1.385" Spring Diameter = .284" Wire Diameter = .026" Approx Coils = 13 (NONE)	<b>SPRING NUMBER 359</b> Free Length = 1.923" Spring Diameter = .238" Wire Diameter = .032" Approx Coils = 24 (NONE)
<b>SPRING NUMBER 362</b> Free Length = 1.394" Spring Diameter = .284" Wire Diameter = .026" Approx Coils = 12 (NONE)	<b>SPRING NUMBER 367</b> Free Length = 1.377" Spring Diameter = .284" Wire Diameter = .026" Approx Coils = 13 (NONE)	<b>SPRING NUMBER 371</b> Free Length = .825" Spring Diameter = .165" Wire Diameter = .040" Approx Coils = 16 (NONE)	<b>SPRING NUMBER 372</b> Free Length = 1.112" Spring Diameter = .278" Wire Diameter = .042" Approx Coils = 16 (NONE)

### MAIN VALVE BODY SPRING SPECIFICATIONS (Small Parts - worm track side)

<b>SPRING NO. 350</b> Free Length = .863" Spring Diameter = .351" Wire Diameter = .028" Approx Coils = 10 (NONE)	<b>SPRING NO. 376</b> Free Length = 1.180" Spring Diameter = .355" Wire Diameter = .085" Approx Coils = 10 (NONE)	<b>SPRING NO. 379</b> Free Length = 1.180" Spring Diameter = .355" Wire Diameter = .085" Approx Coils = 10 (NONE)
--	---	---

\*Note: None = Spring is not colored

Copyright © ATSG 2012

Figure 49



# Technical Service Information

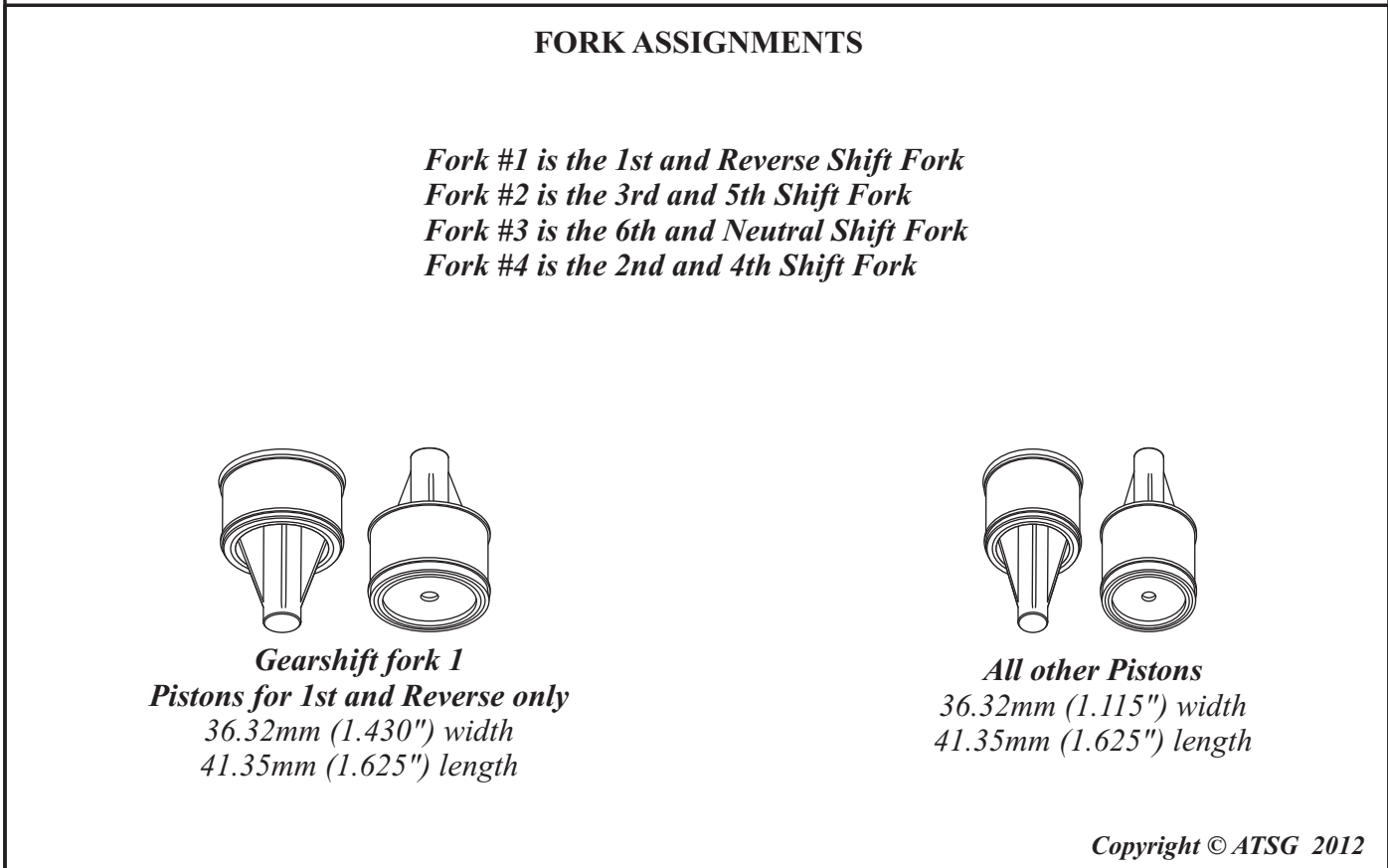
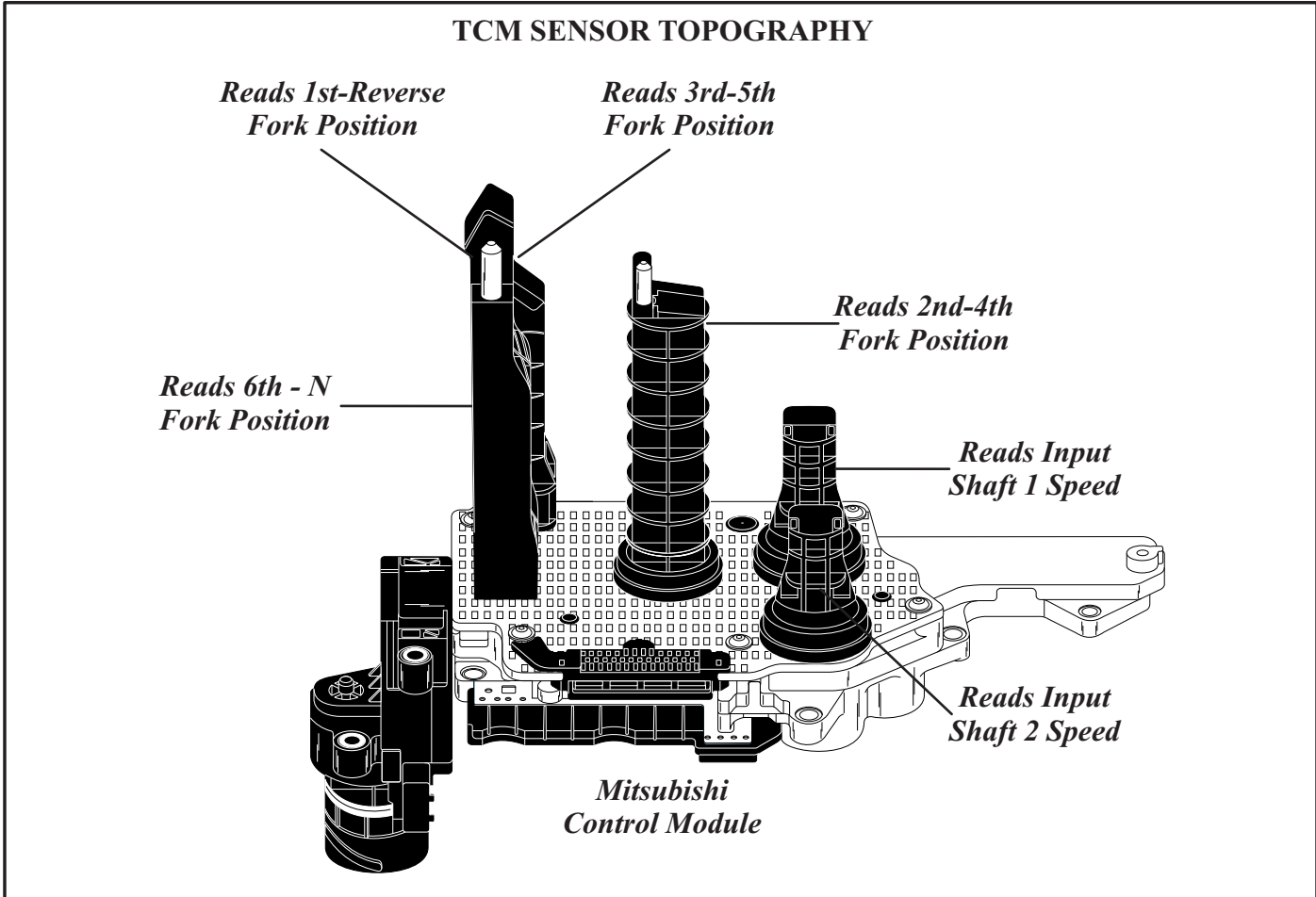

Figure 50

# Technical Service Information

## MITSUBISHI DIAGNOSTIC TROUBLE CODES

U0001: Bus off

U0100: Engine time-out error

P0701: EEPROM System (Malfunction)

P0702: Internal control module, monitoring processor system (Malfunction)

P0712: TC-SST-ECU temperature sensor system (Output low range out)

P0713: TC-SST-ECU temperature sensor system (Output high range out)

P0715: Input shaft 1 (odd number gear axle) speed sensor system (Output high range out)

P0716: Input shaft 1 (odd number gear axle) speed sensor system (Poor performance)

P0717: Input shaft 1 (odd number gear axle) speed sensor system (Output low range out)

P0725: Engine speed signal abnormality

P0746: Line Pressure Solenoid System (Drive current range out)

P0753: Shift select solenoid 1 system (Open circuit)

P0758: Shift select solenoid 2 system (Open circuit)

P0776: Clutch cooling flow solenoid system (Drive current range out)

P0777: Clutch cooling flow solenoid system (Stuck)

P0841: Clutch 1 Pressure Sensor System (Poor performance)

P0842: Clutch 1 pressure sensor system (Output low range out)

P0843: Clutch 1 pressure sensor system (Output high range out)

P0846: Clutch 2 pressure sensor system (Poor performance)

P0847: Clutch 2 pressure sensor system (Output low range out)

P0848: Clutch 2 pressure sensor system (Output high range out)

P0960: Line pressure solenoid system (Open circuit)

P0961: Line pressure solenoid system (Over voltage)

P0962: Line pressure solenoid system (Short to ground)

P0963: Line pressure solenoid system (Short to power supply)

P0964: Clutch cooling flow solenoid system (Open circuit)

P0965: Clutch cooling flow solenoid system (Over voltage)

P0966: Clutch cooling flow solenoid system (Short to ground)

P0967: Clutch cooling flow solenoid system (Short to power supply)

P0968: Shift/cooling switching solenoid system (Open circuit)

P0970: Shift/cooling switching solenoid system (Short to ground)

P0971: Shift/cooling switching solenoid system (Short to power supply)

P0973: Shift select solenoid 1 system (Short to ground)

P0974: Shift select solenoid 1 system (Short to power supply)

P0976: Shift Select Solenoid 2 System (Short to ground)

P0977: Shift Select Solenoid 2 System (Short to power supply)

P180C: Clutch pressure cut spool sticking

P1802: Shift Lever System (LIN communication malfunction)

P1803: Shift Lever System (CAN, LIN Time-out Error)

P1804: Shift Fork Position Sensor 1 and 2 System (Power supply voltage low range out)

P1805: Shift Fork Position Sensor 1 and 2 System (Power supply voltage high range out)

P1806: Shift Fork Position Sensor 3 and 4 System (Power supply voltage low range out)

P1807: Shift Fork Position Sensor 3 and 4 System (Power supply voltage high range out)

P1808: TC-SST-ECU temperature, fluid temperature sensor system (Correlation error)

## Technical Service Information

### MITSUBISHI DIAGNOSTIC TROUBLE CODES

P181B: Clutch 1 (Pressure low range out)  
P181C: Clutch 1 (Pressure high range out)  
P181E: Clutch 2 (Pressure low range out)  
P181F: Clutch 2 (Pressure high range out)  
P182A: Shift Fork Position Sensor 3 System (Voltage low range out)  
P182B: Shift fork position sensor 3 system (Voltage high range out)  
P182C: Shift fork position sensor 3 system (Output range out)  
P182D: Shift fork position sensor 3 system (Neutral)  
P182E: Shift fork position sensor 3 system (Poor performance)  
P1820: Shift fork position sensor 1 system (Voltage low range out)  
P1821: Shift fork position sensor 1 system (Voltage high range out)  
P1822: Shift fork position sensor 1 system (Output range out)  
P1824: Shift fork position sensor 1 system (Poor performance)  
P1825: Shift fork position sensor 2 system (Voltage low range out)  
P1826: Shift fork position sensor 2 system (Voltage high range out)  
P1827: Shift fork position sensor 2 system (Output range out)  
P1829: Shift fork position sensor 2 system (Poor performance)  
P183D: Shift Fork 2 Malfunction  
P1831: Shift fork position sensor 4 system (Voltage low range out)  
P1832: Shift fork position sensor 4 system (Voltage high range out)  
P1833: Shift fork position sensor 4 system (Output range out)  
P1835: Shift fork position sensor 4 system (Poor performance)  
P1836: Shift fork 1 malfunction  
P1844: Shift fork 3 malfunction  
P184B: Shift fork 4 malfunction  
P1852: Shift fork 1 or 2 opposite direction movement  
P1855: Shift fork 3 or 4 opposite direction movement  
P185D: Clutch open not possible  
P1857: Odd number gear axle interlock  
P1858: Even number gear axle interlock  
P186A: High side 3 system (Over current)  
P186B: High side 3 system (Open circuit)  
P186C: High side 3 system (Short to power supply)  
P186D: High side 1 system (Voltage low range out)  
P186E: High side 2 system (Voltage low range out)  
P186F: High side 3 system (Voltage low range out)  
P1863: High side 1 system (Open circuit)  
P1864: High side 1 system (Short to power supply)  
P1866: High side 2 system (Over current)  
P1867: High side 2 system (Open circuit)  
P1868: High side 2 system (Short to power supply)  
P1870: Engine torque signal abnormality  
P1871: APS system (Signal abnormality)  
P1872: Between shift lever and TC-SST system (Q-A function abnormality)  
P1873: Clutch 1 System (Pressure abnormality)  
P1874: Clutch 2 System (Pressure abnormality)

## Technical Service Information

### MITSUBISHI DIAGNOSTIC TROUBLE CODES

P1876: Gear block 1st  
P1877: Gear block 2nd  
P1878: Gear block 3rd  
P1879: Gear block 4th  
P187A: Gear block 5th  
P187B: Gear block 6th  
P187C: Gear block reverse  
P1880: EOL Mode Active  
P1881: Twin clutch SST control mode switch system (Malfunction)  
P1885: Shift Fork 1 Jump Out  
P1886: Shift Fork 2 Jump Out  
P1887: Shift Fork 3 Jump Out  
P1890: Tech-in Not Completed

P2718: Clutch/shift pressure solenoid 1 system (Open circuit)  
P2719: Clutch/shift pressure solenoid 1 system (Over current)  
P2720: Clutch/shift pressure solenoid 1 system (Short to ground)  
P2721: Clutch/shift pressure solenoid 1 system (Short to power supply)  
P2727: Clutch/shift pressure solenoid 2 system (Open circuit)  
P2728: Clutch/shift pressure solenoid 2 system (Over current)  
P2729: Clutch/shift pressure solenoid 2 system (Short to ground)  
P2730: Clutch/shift pressure solenoid 2 system (Short to power supply)  
P2733: Clutch/shift switching solenoid 1, spool stuck  
P2736: Clutch/shift switching solenoid 1 system (Open circuit)  
P2738: Clutch/shift switching solenoid 1 system (Short to ground)  
P2739: Clutch/shift switching solenoid 1 system (Short to power supply)  
P2742: Fluid Temperature Sensor System (Output low range out)  
P2743: Fluid temperature sensor system (Output high range out)  
P2766: Input shaft 2 (even number gear axle) speed sensor system (Poor performance)  
P2809: Clutch/shift switching solenoid 2, spool stuck  
P2812: Clutch/shift switching solenoid 2 system (Open circuit)  
P2814: Clutch/shift switching solenoid 2 system (Short to ground)  
P2815: Clutch/shift switching solenoid 2 system (Short to power supply)



## VALVE BODY MAPPING DCT450

*PARTIAL HYDRAULIC  
SCHEMATIC FOR THE  
ODD FORK CONTROL VALVE*

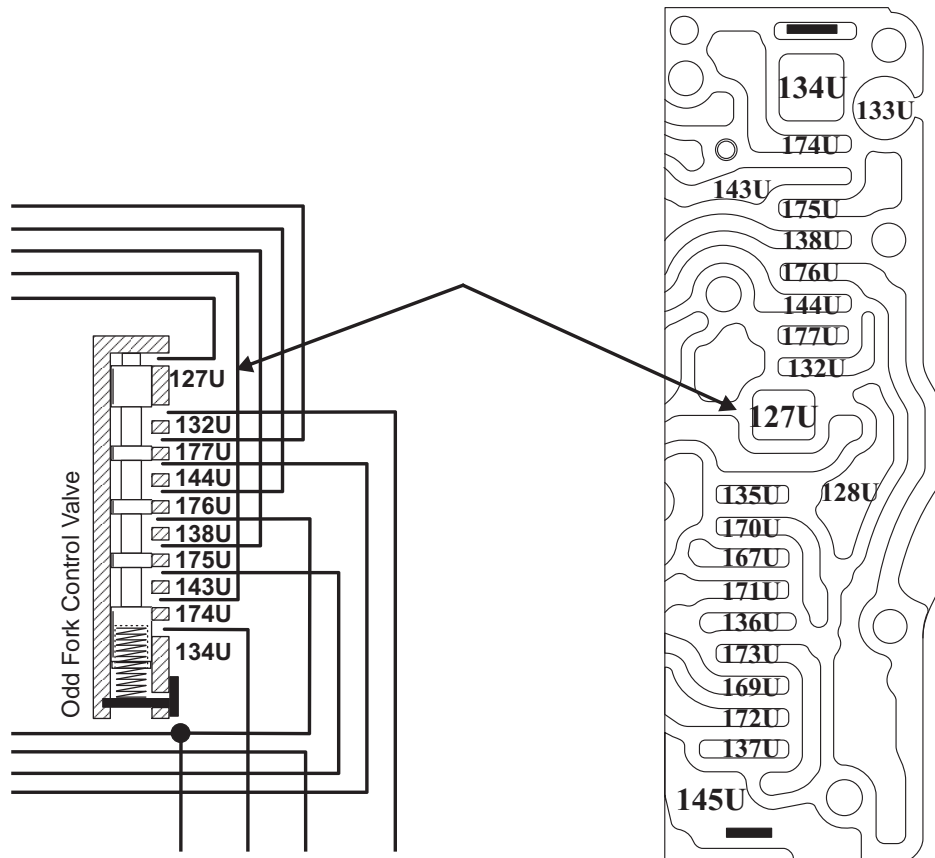

**100U SERIES FOR  
MAIN VALVE BODY CASTING**  
(Example of use is applied on all castings)

### HOW TO USE THIS MANUAL

All castings and spacer plates have been numbered so they can be identified in an oil diagram. **Example: Circuit 127U** passage is located in the Main Valve Body Upper side (100U Series). This passage can now be located in the partial oil circuit diagram shown above. Spacer plate orifice sizes and locations are also identified in the oil circuit diagram labeled Valve Body Mapping.

Copyright © ATSG 2012



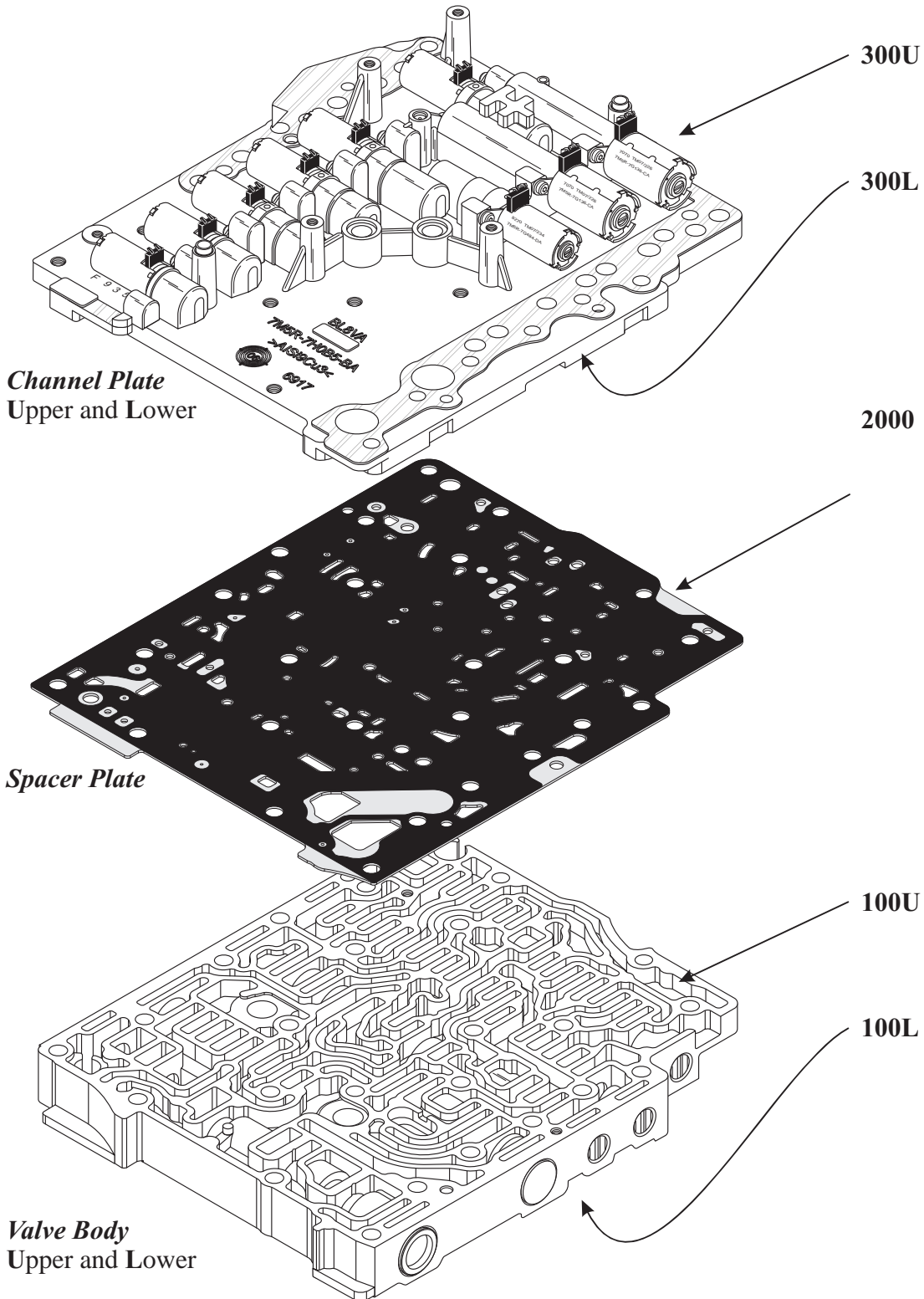

Copyright © ATSG 2012

# Technical Service Information

## MAIN VALVE BODY LOWER SIDE 100L Series

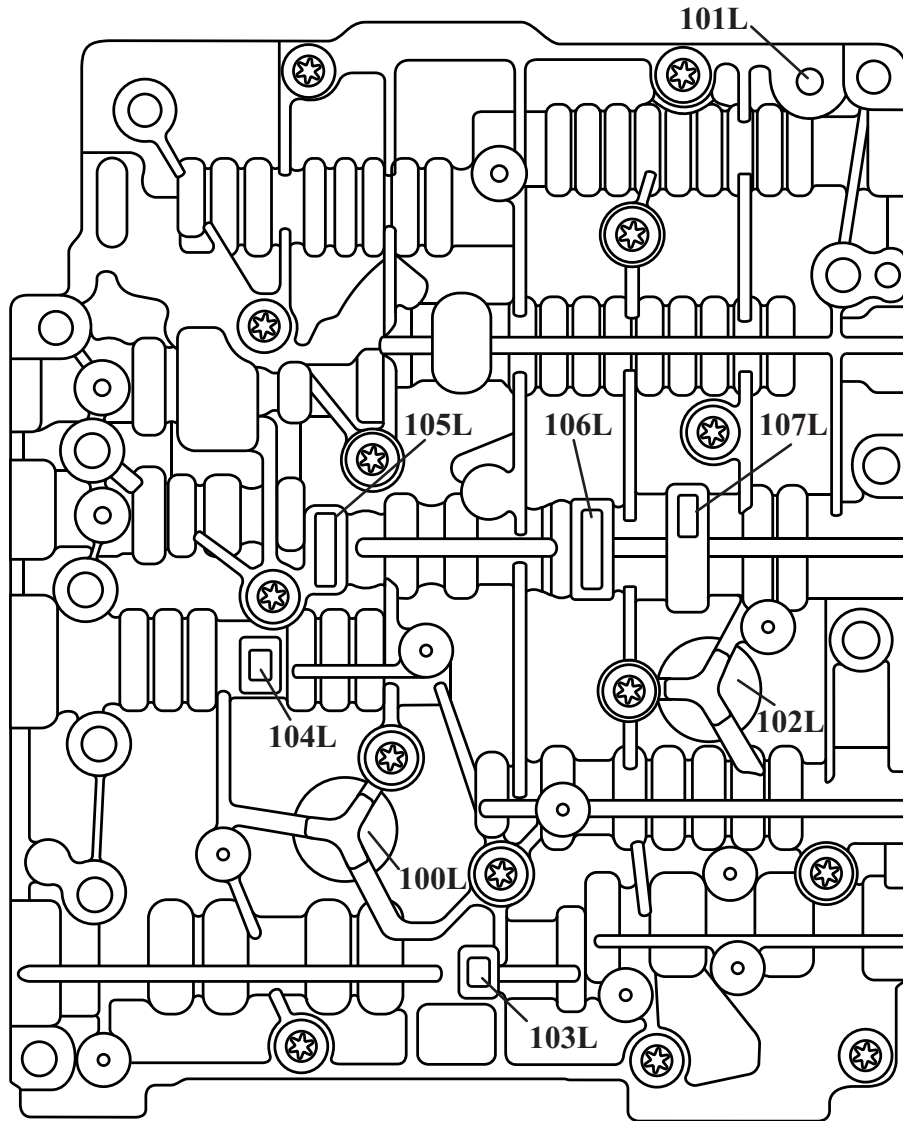

Copyright © ATSG 2012

## MAIN VALVE BODY UPPER SIDE 100U Series

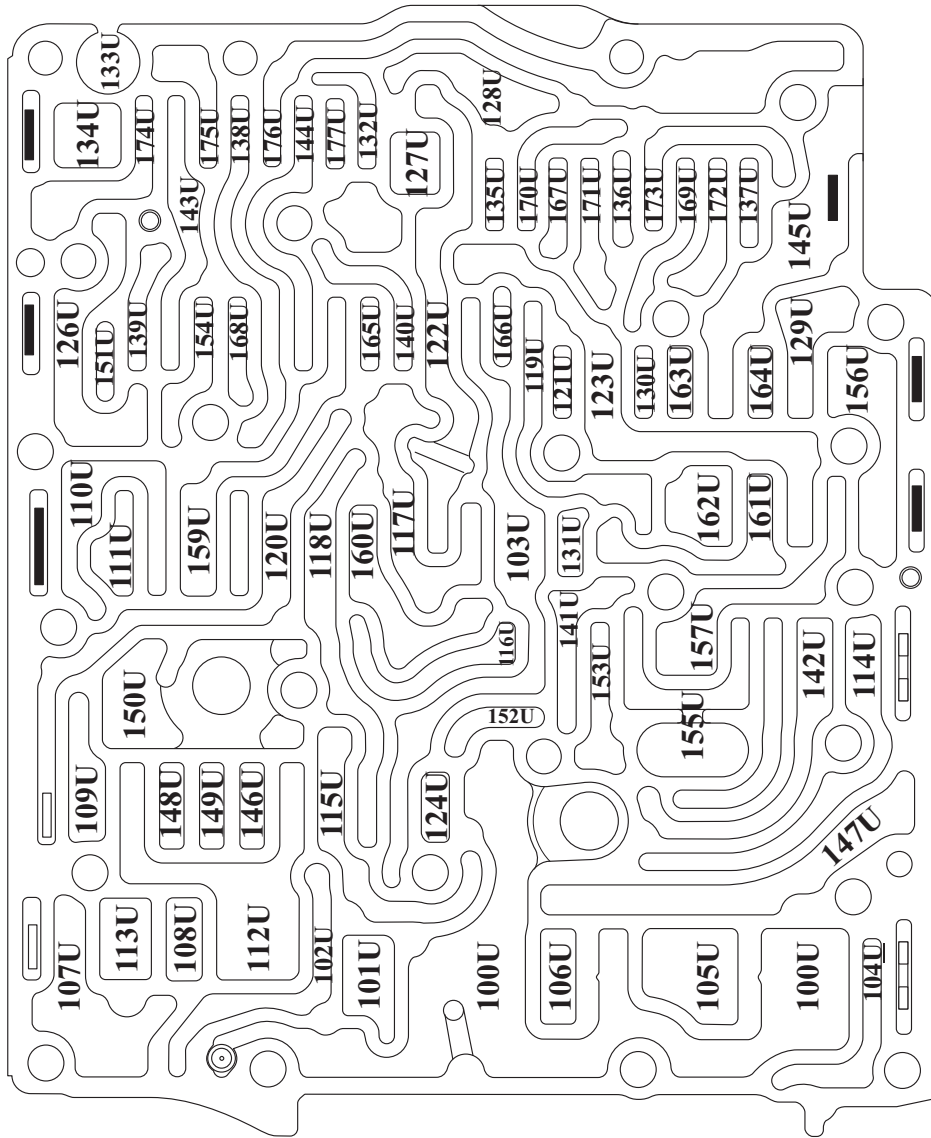

Copyright © ATSG 2012

# Technical Service Information

## MAIN SPACER PLATE 2000 Series

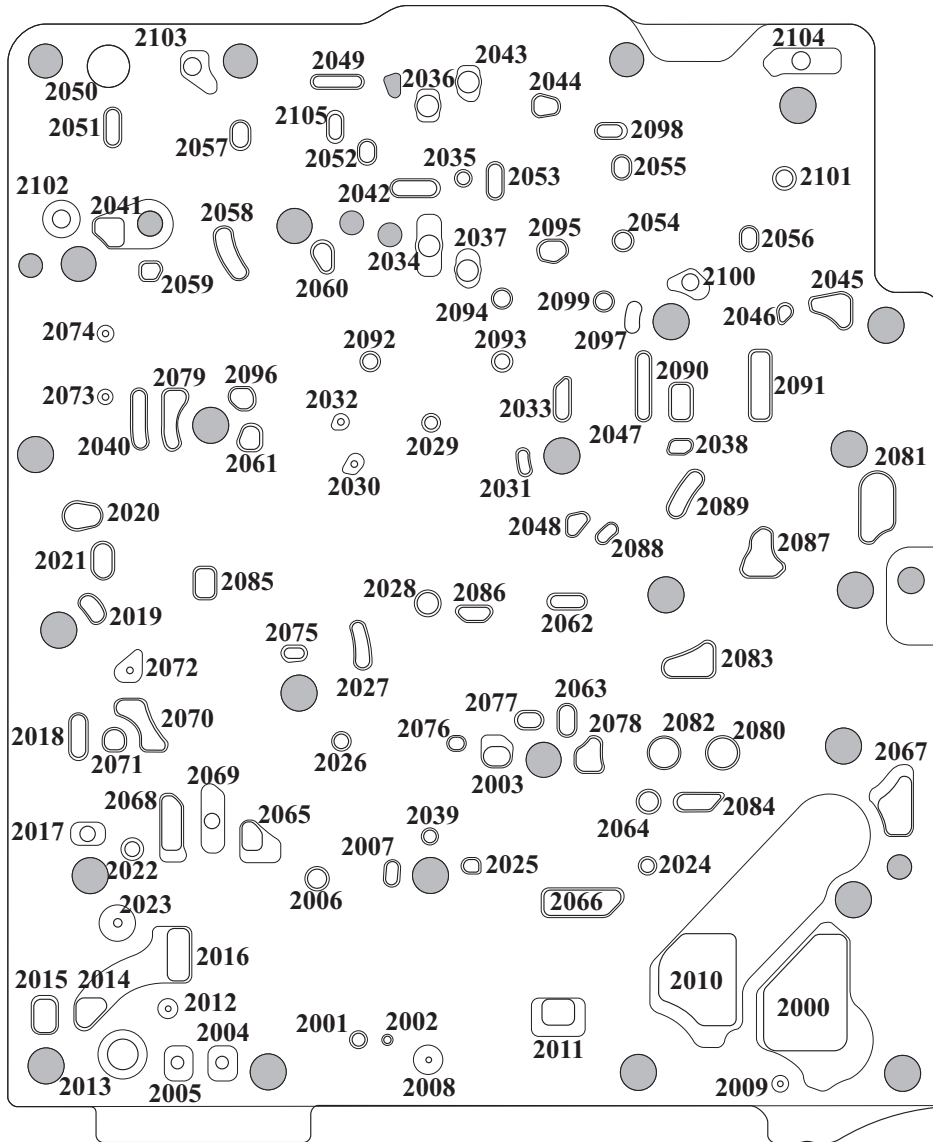

Copyright © ATSG 2012

# Technical Service Information

## SOLENOID BODY/CHANNEL PLATE 300L Series

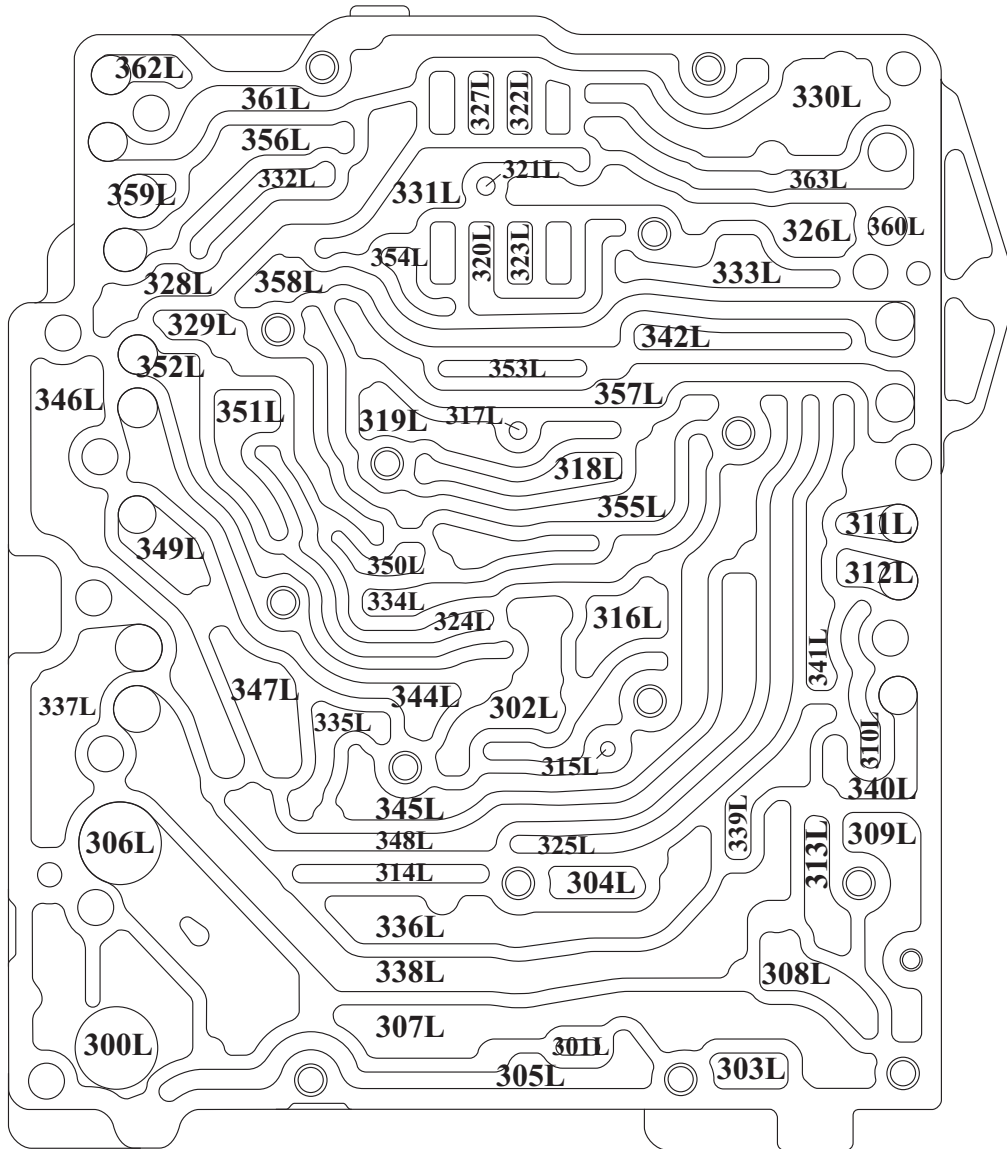

Copyright © ATSG 2012

# Technical Service Information

## SOLENOID BODY/CHANNEL PLATE 300U Series

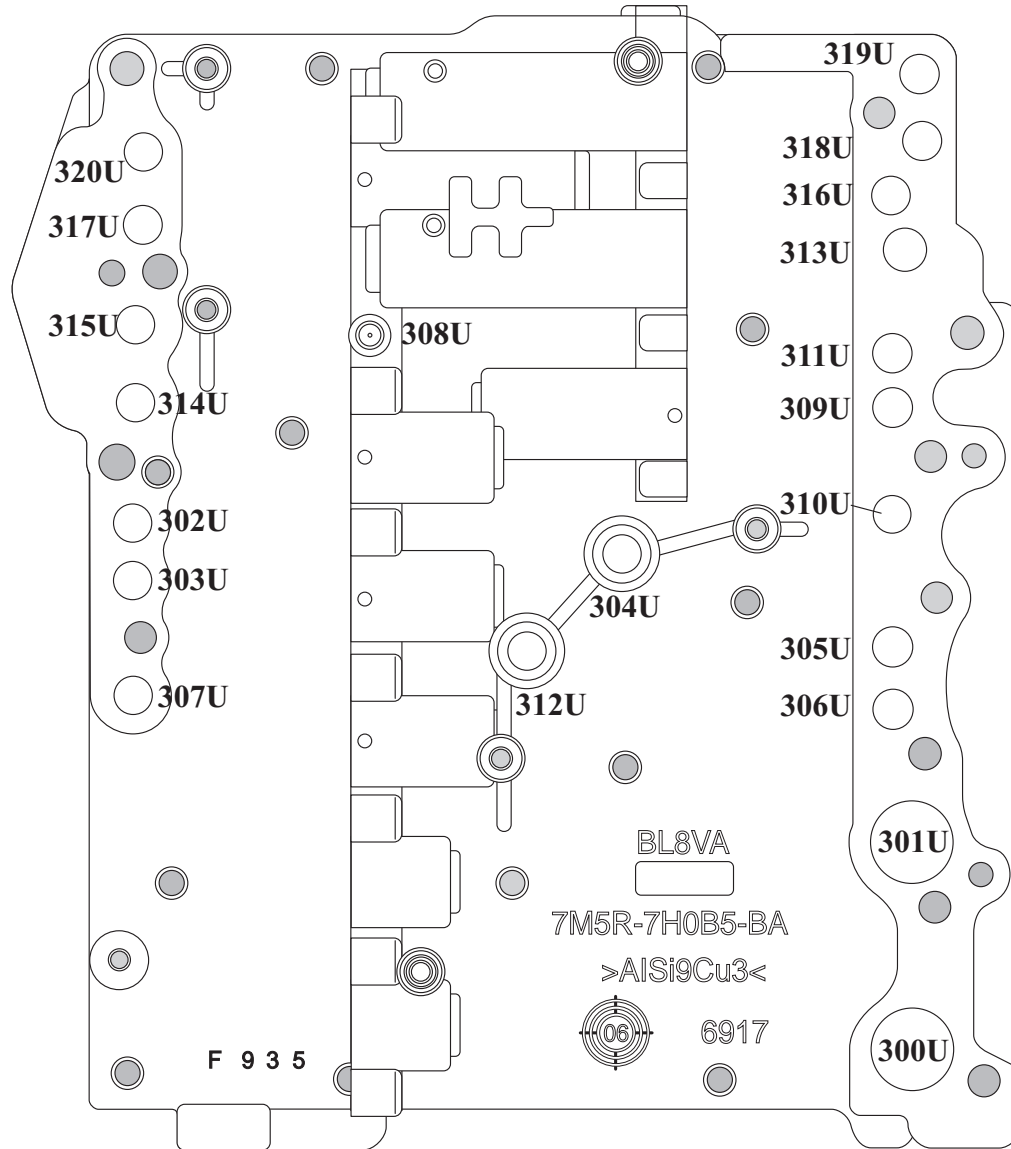

Copyright © ATSG 2012



# Technical Service Information

## CASE PASSAGE IDENTIFICATION CP Series

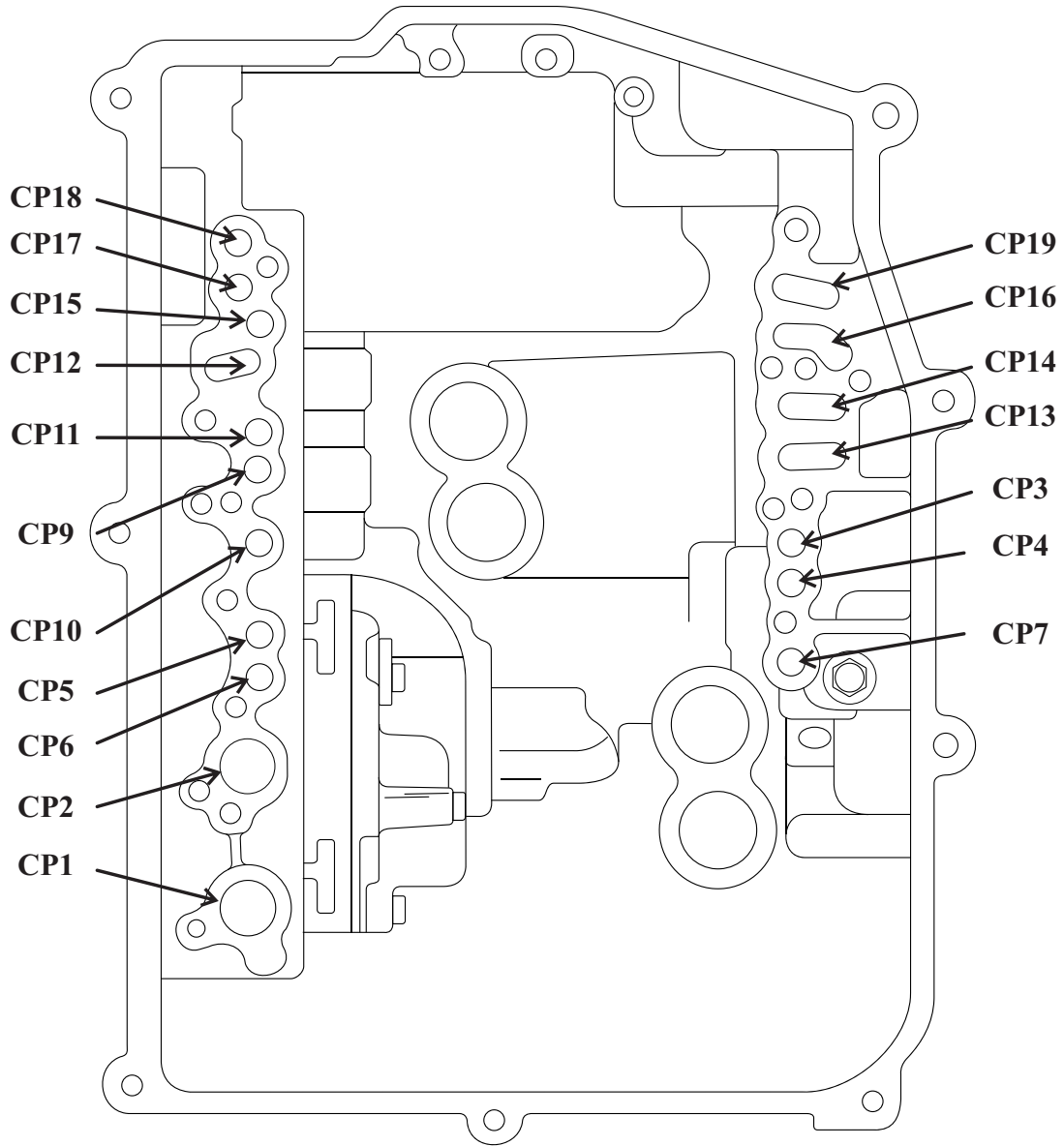

Copyright © ATSG 2012



**6DCT450 Dual Wet Clutch  
Getrag Powershift Transmission**

Volvo - MPS6  
Ford - DPS6

Copyright © 2012 ATSG

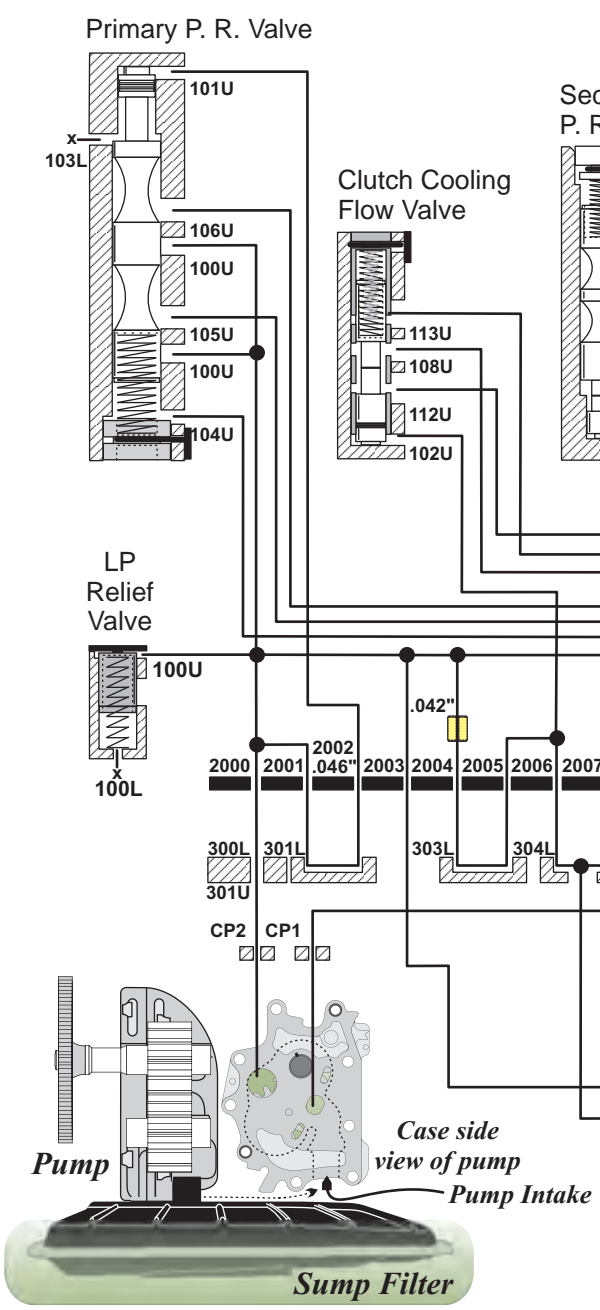
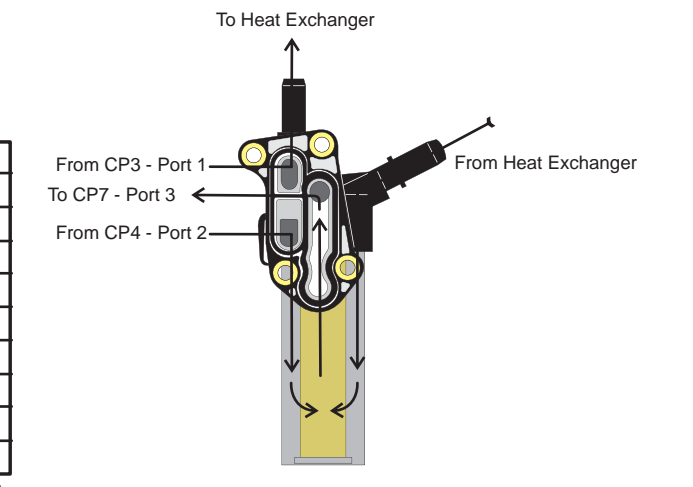
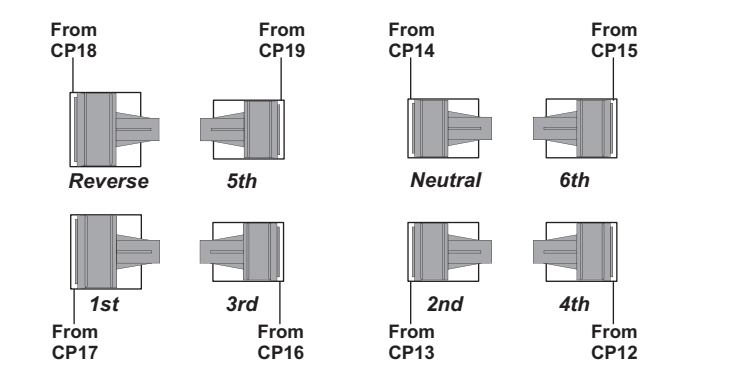
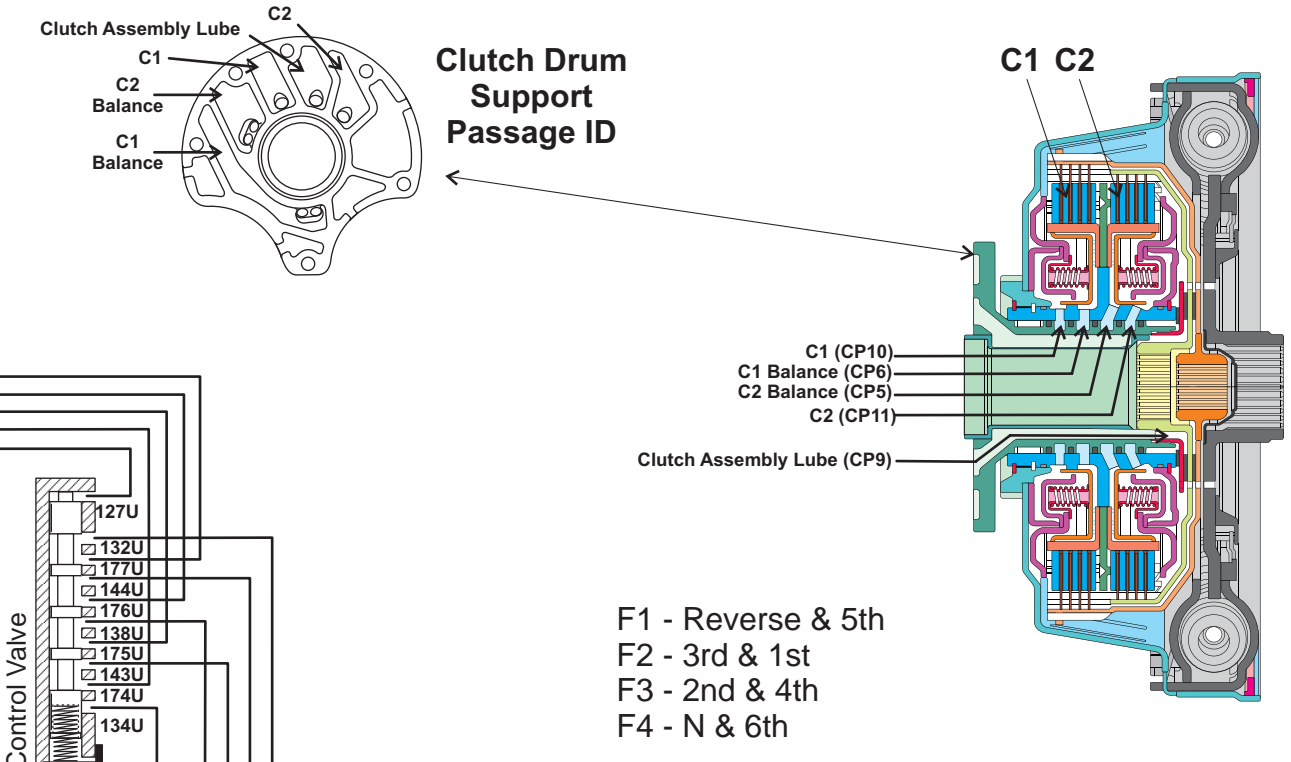
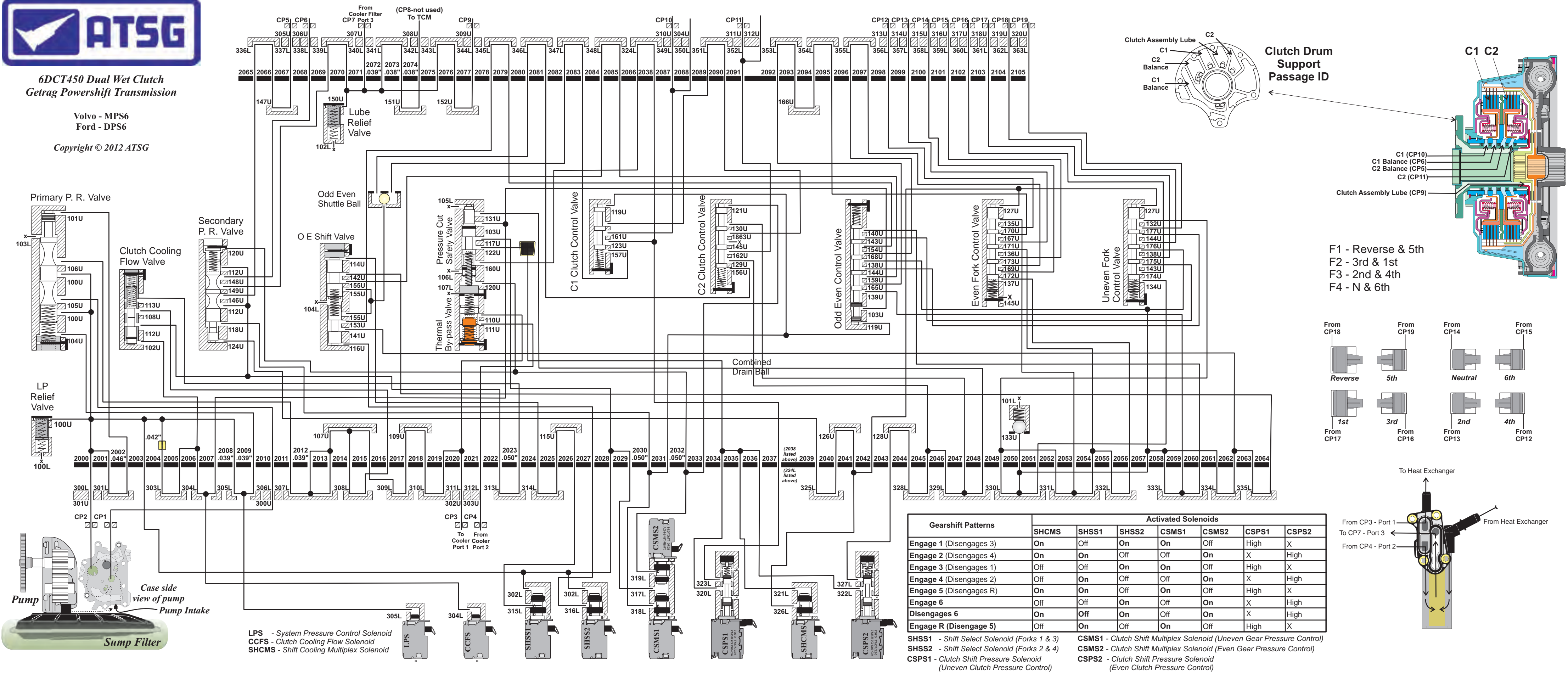

LPS - System Pressure Control Solenoid  
CCFS - Clutch Cooling Flow Solenoid  
SHCMS - Shift Cooling Multiplex Solenoid

Gearshift Patterns	Activated Solenoids							
	SHCMS	SHSS1	SHSS2	CSMS1	CSMS2	CSPS1	CSPS2	
Engage 1 (Disengages 3)	On	Off	On	On	Off	High	X	
Engage 2 (Disengages 4)	On	On	Off	Off	On	X	High	
Engage 3 (Disengages 1)	Off	Off	On	On	Off	High	X	
Engage 4 (Disengages 2)	Off	On	Off	Off	On	X	High	
Engage 5 (Disengages R)	On	On	Off	On	Off	High	X	
Engage 6	Off	Off	On	Off	On	X	High	
Disengages 6	On	Off	On	Off	On	X	High	
Engage R (Disengage 5)	Off	On	Off	On	Off	High	X	

SHSS1 - Shift Select Solenoid (Forks 1 & 3)  
SHSS2 - Shift Select Solenoid (Forks 2 & 4)  
CSMS1 - Clutch Shift Multiplex Solenoid (Uneven Gear Pressure Control)  
CSMS2 - Clutch Shift Multiplex Solenoid (Even Gear Pressure Control)  
CSPS1 - Clutch Shift Pressure Solenoid (Uneven Clutch Pressure Control)  
CSPS2 - Clutch Shift Pressure Solenoid (Even Clutch Pressure Control)



**6DCT450 Dual Wet Clutch  
Getrag Powershift Transmission**

Volvo - MPS6  
Ford - DPS6

Copyright © 2012 ATSG

**Park/Neutral**

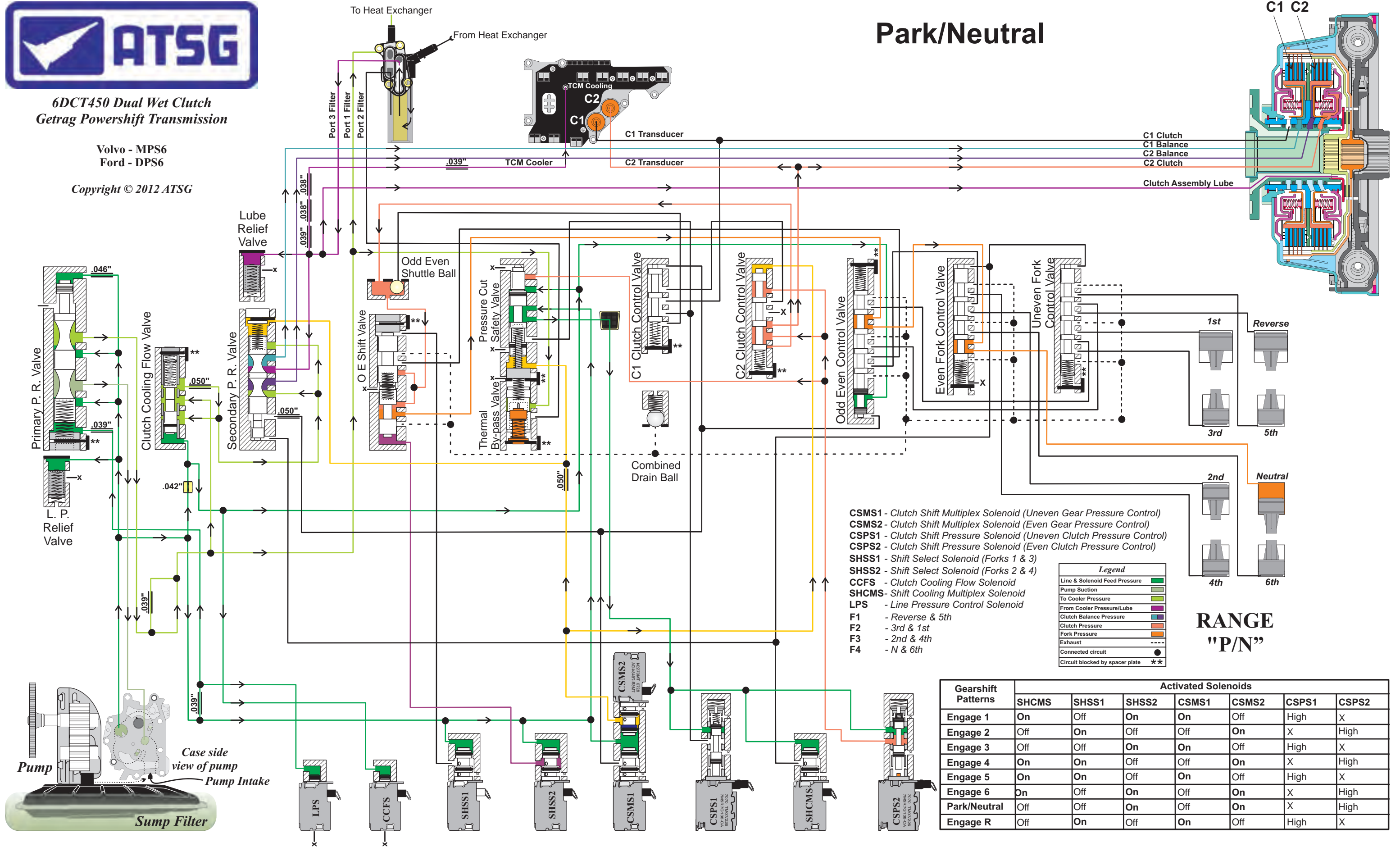

C1 Clutch  
C1 Balance  
C2 Balance  
C2 Clutch  
Clutch Assembly Lube

**RANGE  
"P/N"**

- CSMS1 - Clutch Shift Multiplex Solenoid (Uneven Gear Pressure Control)
  - CSMS2 - Clutch Shift Multiplex Solenoid (Even Gear Pressure Control)
  - CSPS1 - Clutch Shift Pressure Solenoid (Uneven Clutch Pressure Control)
  - CSPS2 - Clutch Shift Pressure Solenoid (Even Clutch Pressure Control)
  - SHSS1 - Shift Select Solenoid (Forks 1 & 3)
  - SHSS2 - Shift Select Solenoid (Forks 2 & 4)
  - CCFS - Clutch Cooling Flow Solenoid
  - SHCMS - Shift Cooling Multiplex Solenoid
  - LPS - Line Pressure Control Solenoid
- F1 - Reverse & 5th  
F2 - 3rd & 1st  
F3 - 2nd & 4th  
F4 - N & 6th

**Legend**

Line & Solenoid Feed Pressure	Green
Pump Suction	Light Green
To Cooler Pressure	Light Blue
From Cooler Pressure/Lube	Purple
Clutch Balance Pressure	Dark Blue
Clutch Pressure	Orange
Fork Pressure	Red
Exhaust	Black
Connected circuit	Black dot
Circuit blocked by spacer plate	**

Gearshift Patterns	Activated Solenoids						
	SHCMS	SHSS1	SHSS2	CSMS1	CSMS2	CSPS1	CSPS2
Engage 1	On	Off	On	On	Off	High	X
Engage 2	Off	On	Off	Off	On	X	High
Engage 3	Off	Off	On	On	Off	High	X
Engage 4	On	On	Off	Off	On	X	High
Engage 5	On	On	Off	On	Off	High	X
Engage 6	On	Off	On	Off	On	X	High
Park/Neutral	Off	Off	On	Off	On	X	High
Engage R	Off	On	Off	On	Off	High	X





**6DCT450 Dual Wet Clutch  
Getrag Powershift Transmission**

Volvo - MPS6  
Ford - DPS6

Copyright © 2012 ATSG

**Reverse**

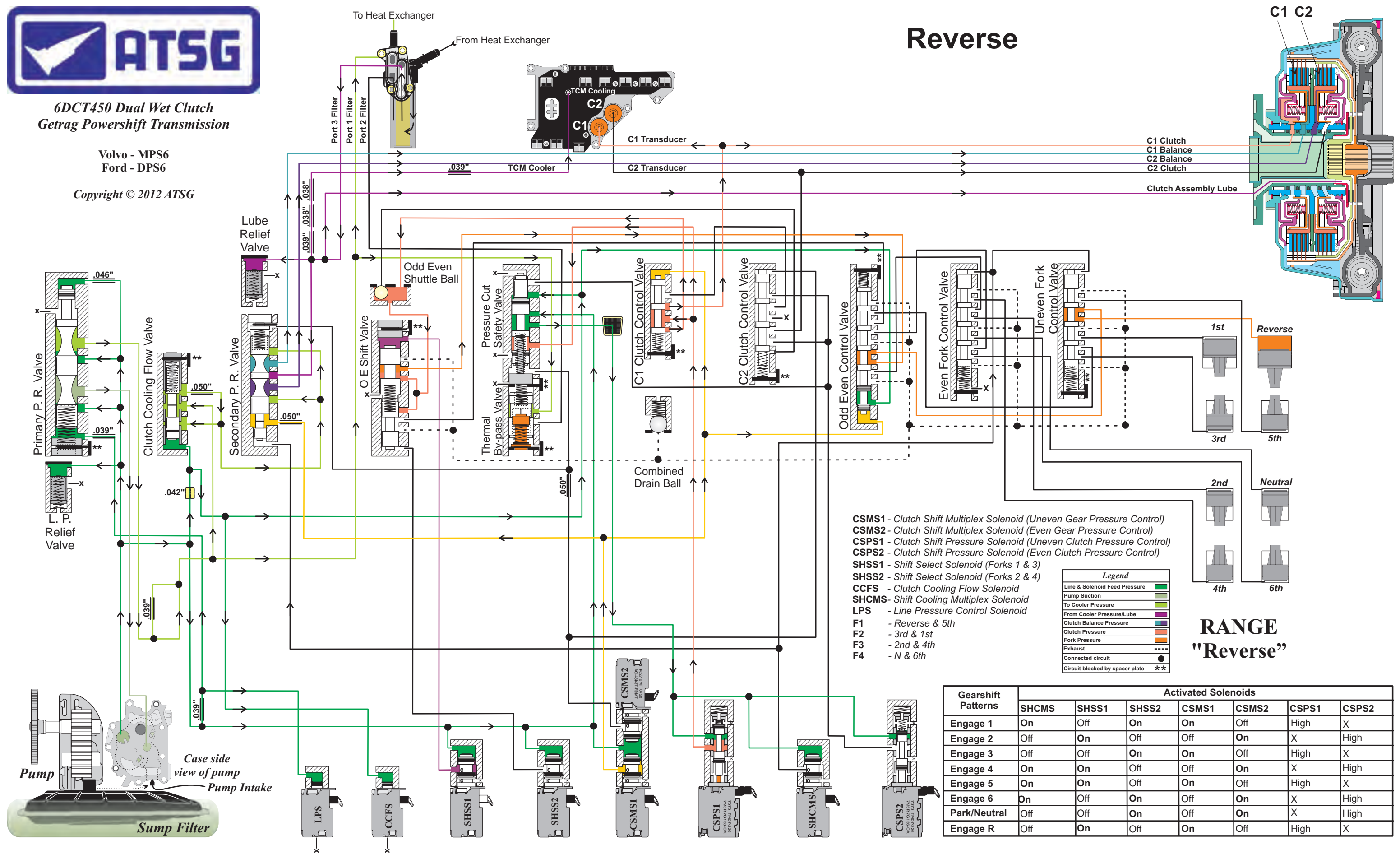

C1 Clutch  
C1 Balance  
C2 Balance  
C2 Clutch  
Clutch Assembly Lube

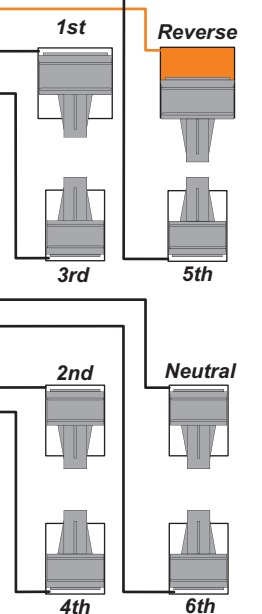
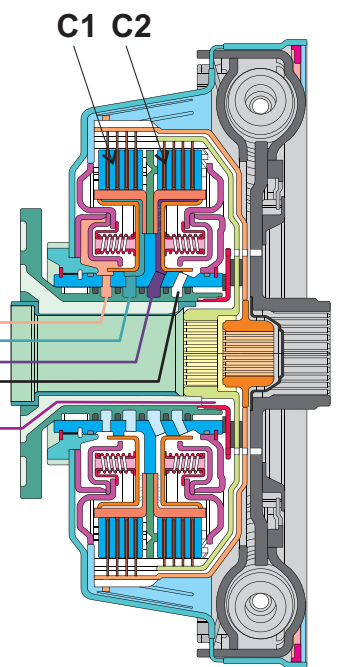

**RANGE  
"Reverse"**

- CSMS1 - Clutch Shift Multiplex Solenoid (Uneven Gear Pressure Control)
- CSMS2 - Clutch Shift Multiplex Solenoid (Even Gear Pressure Control)
- CSPS1 - Clutch Shift Pressure Solenoid (Uneven Clutch Pressure Control)
- CSPS2 - Clutch Shift Pressure Solenoid (Even Clutch Pressure Control)
- SHSS1 - Shift Select Solenoid (Forks 1 & 3)
- SHSS2 - Shift Select Solenoid (Forks 2 & 4)
- CCFS - Clutch Cooling Flow Solenoid
- SHCMS - Shift Cooling Multiplex Solenoid
- LPS - Line Pressure Control Solenoid
- F1 - Reverse & 5th
- F2 - 3rd & 1st
- F3 - 2nd & 4th
- F4 - N & 6th

**Legend**

Line & Solenoid Feed Pressure	Green
Pump Suction	Light Green
To Cooler Pressure	Light Blue
From Cooler Pressure/Lube	Purple
Clutch Balance Pressure	Blue
Clutch Pressure	Orange
Fork Pressure	Red
Exhaust	Black
Connected circuit	●
Circuit blocked by spacer plate	**

Gearshift Patterns	Activated Solenoids						
	SHCMS	SHSS1	SHSS2	CSMS1	CSMS2	CSPS1	CSPS2
Engage 1	On	Off	On	On	Off	High	X
Engage 2	Off	On	Off	Off	On	X	High
Engage 3	Off	Off	On	On	Off	High	X
Engage 4	On	On	Off	Off	On	X	High
Engage 5	On	On	Off	On	Off	High	X
Engage 6	On	Off	On	Off	On	X	High
Park/Neutral	Off	Off	On	Off	On	X	High
Engage R	Off	On	Off	On	Off	High	X



**6DCT450 Dual Wet Clutch  
Getrag Powershift Transmission**

Volvo - MPS6  
Ford - DPS6

Copyright © 2012 ATSG

**1st Gear**

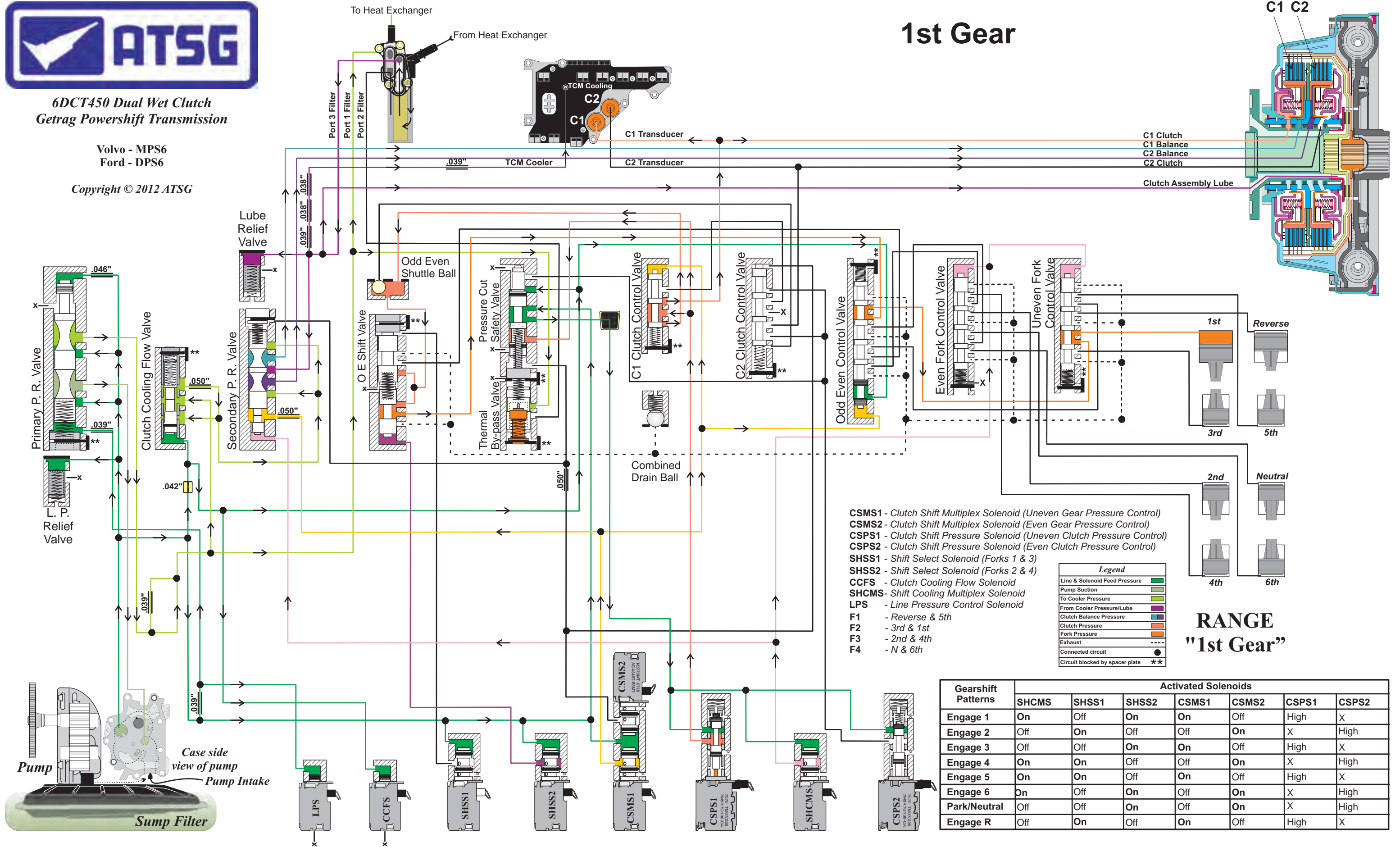

C1 Clutch  
C1 Balance  
C2 Balance  
C2 Clutch  
Clutch Assembly Lube

**RANGE  
"1st Gear"**

- CSMS1 - Clutch Shift Multiplex Solenoid (Uneven Gear Pressure Control)
  - CSMS2 - Clutch Shift Multiplex Solenoid (Even Gear Pressure Control)
  - CSPS1 - Clutch Shift Pressure Solenoid (Uneven Clutch Pressure Control)
  - CSPS2 - Clutch Shift Pressure Solenoid (Even Clutch Pressure Control)
  - SHSS1 - Shift Select Solenoid (Forks 1 & 3)
  - SHSS2 - Shift Select Solenoid (Forks 2 & 4)
  - CCFS - Clutch Cooling Flow Solenoid
  - SHCMS - Shift Cooling Multiplex Solenoid
  - LPS - Line Pressure Control Solenoid
- F1 - Reverse & 5th  
F2 - 3rd & 1st  
F3 - 2nd & 4th  
F4 - N & 6th

**Legend**

Line & Solenoid Feed Pressure	Green
Pump Suction	Light Green
To Cooler Pressure	Light Blue
From Cooler Pressure/Lube	Purple
Clutch Balance Pressure	Blue
Clutch Pressure	Orange
Fork Pressure	Red
Exhaust	Black
Connected circuit	●
Circuit blocked by spacer plate	**

Gearshift Patterns	Activated Solenoids						
	SHCMS	SHSS1	SHSS2	CSMS1	CSMS2	CSPS1	CSPS2
Engage 1	On	Off	On	On	Off	High	X
Engage 2	Off	On	Off	Off	On	X	High
Engage 3	Off	Off	On	On	Off	High	X
Engage 4	On	On	Off	Off	On	X	High
Engage 5	On	On	Off	On	Off	High	X
Engage 6	On	Off	On	Off	On	X	High
Park/Neutral	Off	Off	On	Off	On	X	High
Engage R	Off	On	Off	On	Off	High	X

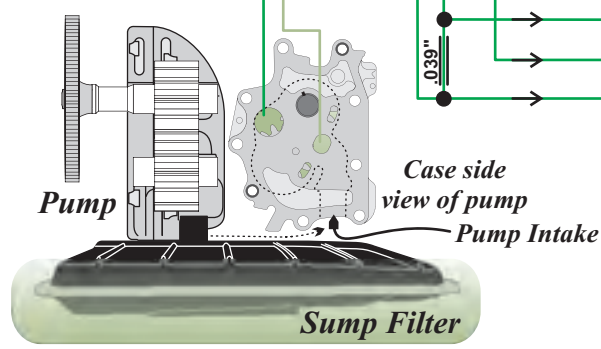



**6DCT450 Dual Wet Clutch  
Getrag Powershift Transmission**

Volvo - MPS6  
Ford - DPS6

Copyright © 2012 ATSG

**2nd Gear**

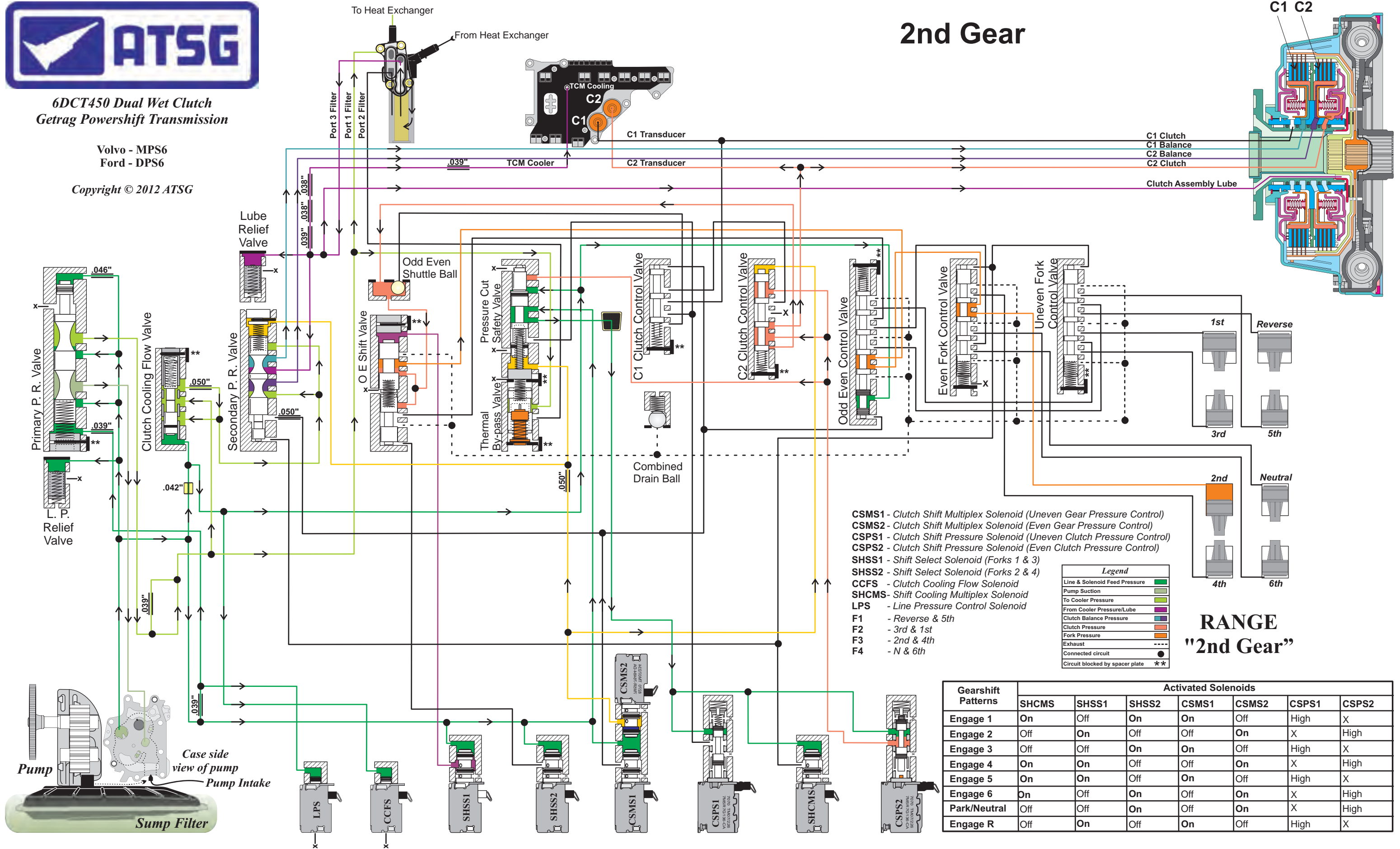

**RANGE  
"2nd Gear"**

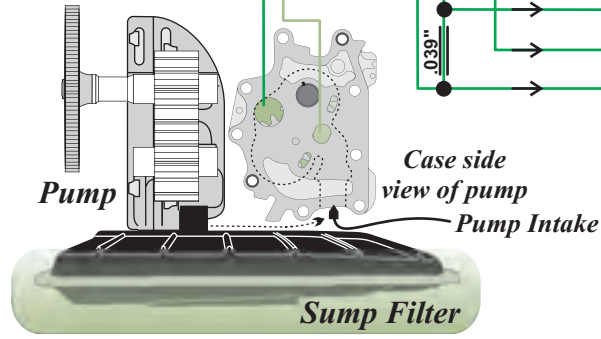
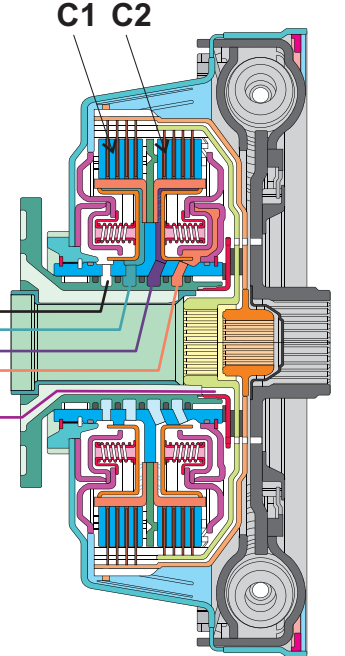





**6DCT450 Dual Wet Clutch  
Getrag Powershift Transmission**

Volvo - MPS6  
Ford - DPS6

Copyright © 2012 ATSG

**3rd Gear**

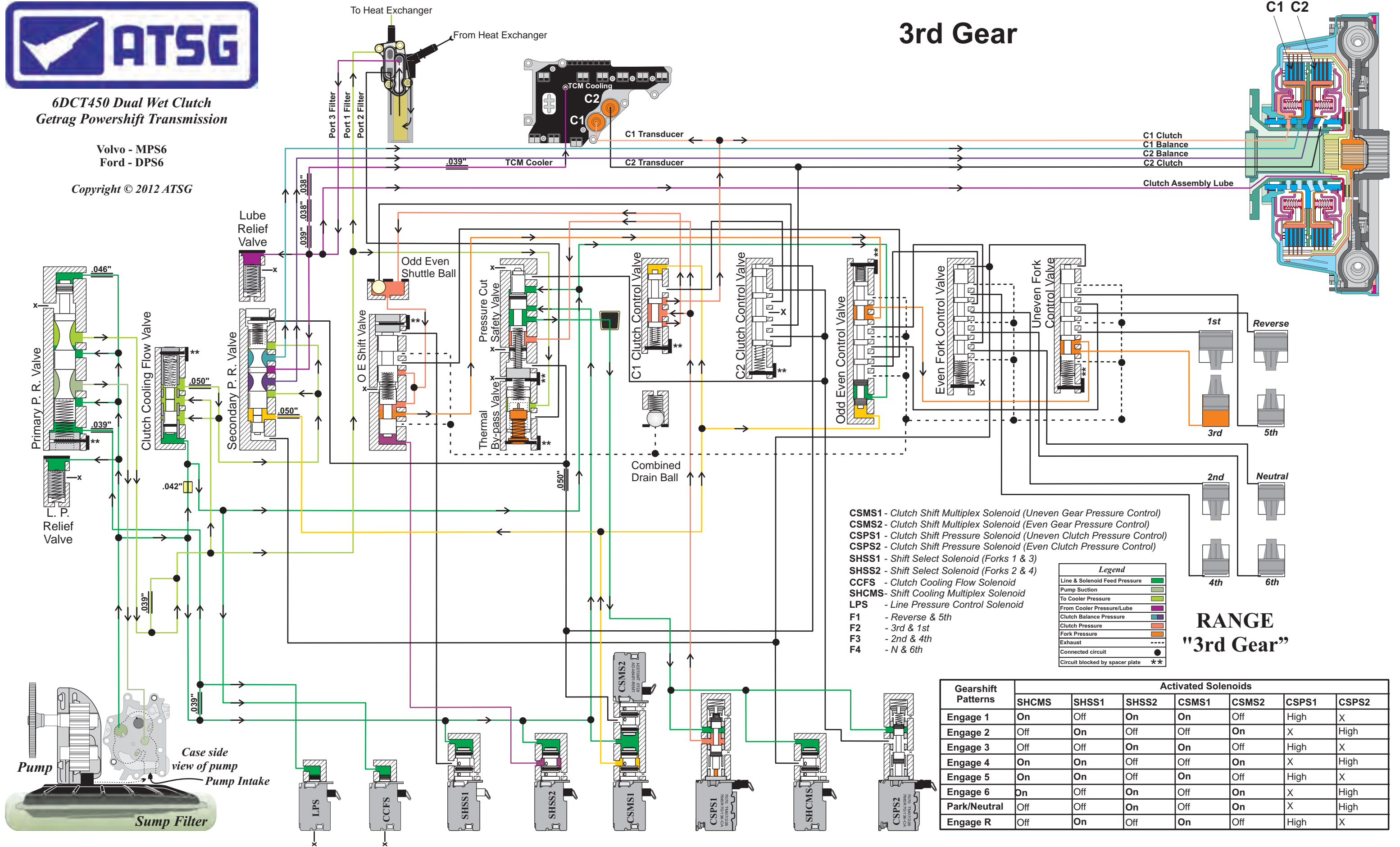

C1 Clutch  
C1 Balance  
C2 Balance  
C2 Clutch  
Clutch Assembly Lube

**RANGE  
"3rd Gear"**

- CSMS1 - Clutch Shift Multiplex Solenoid (Uneven Gear Pressure Control)
- CSMS2 - Clutch Shift Multiplex Solenoid (Even Gear Pressure Control)
- CSPS1 - Clutch Shift Pressure Solenoid (Uneven Clutch Pressure Control)
- CSPS2 - Clutch Shift Pressure Solenoid (Even Clutch Pressure Control)
- SHSS1 - Shift Select Solenoid (Forks 1 & 3)
- SHSS2 - Shift Select Solenoid (Forks 2 & 4)
- CCFS - Clutch Cooling Flow Solenoid
- SHCMS - Shift Cooling Multiplex Solenoid
- LPS - Line Pressure Control Solenoid
- F1 - Reverse & 5th
- F2 - 3rd & 1st
- F3 - 2nd & 4th
- F4 - N & 6th

**Legend**

Line & Solenoid Feed Pressure	Green
Pump Suction	Light Green
To Cooler Pressure	Light Blue
From Cooler Pressure/Lube	Purple
Clutch Balance Pressure	Blue
Clutch Pressure	Orange
Fork Pressure	Red
Exhaust	Black
Connected circuit	●
Circuit blocked by spacer plate	**

Gearshift Patterns	Activated Solenoids						
	SHCMS	SHSS1	SHSS2	CSMS1	CSMS2	CSPS1	CSPS2
Engage 1	On	Off	On	On	Off	High	X
Engage 2	Off	On	Off	Off	On	X	High
Engage 3	Off	Off	On	On	Off	High	X
Engage 4	On	On	Off	Off	On	X	High
Engage 5	On	On	Off	On	Off	High	X
Engage 6	On	Off	On	Off	On	X	High
Park/Neutral	Off	Off	On	Off	On	X	High
Engage R	Off	On	Off	On	Off	High	X



**6DCT450 Dual Wet Clutch  
Getrag Powershift Transmission**

Volvo - MPS6  
Ford - DPS6

Copyright © 2012 ATSG

**4th Gear**

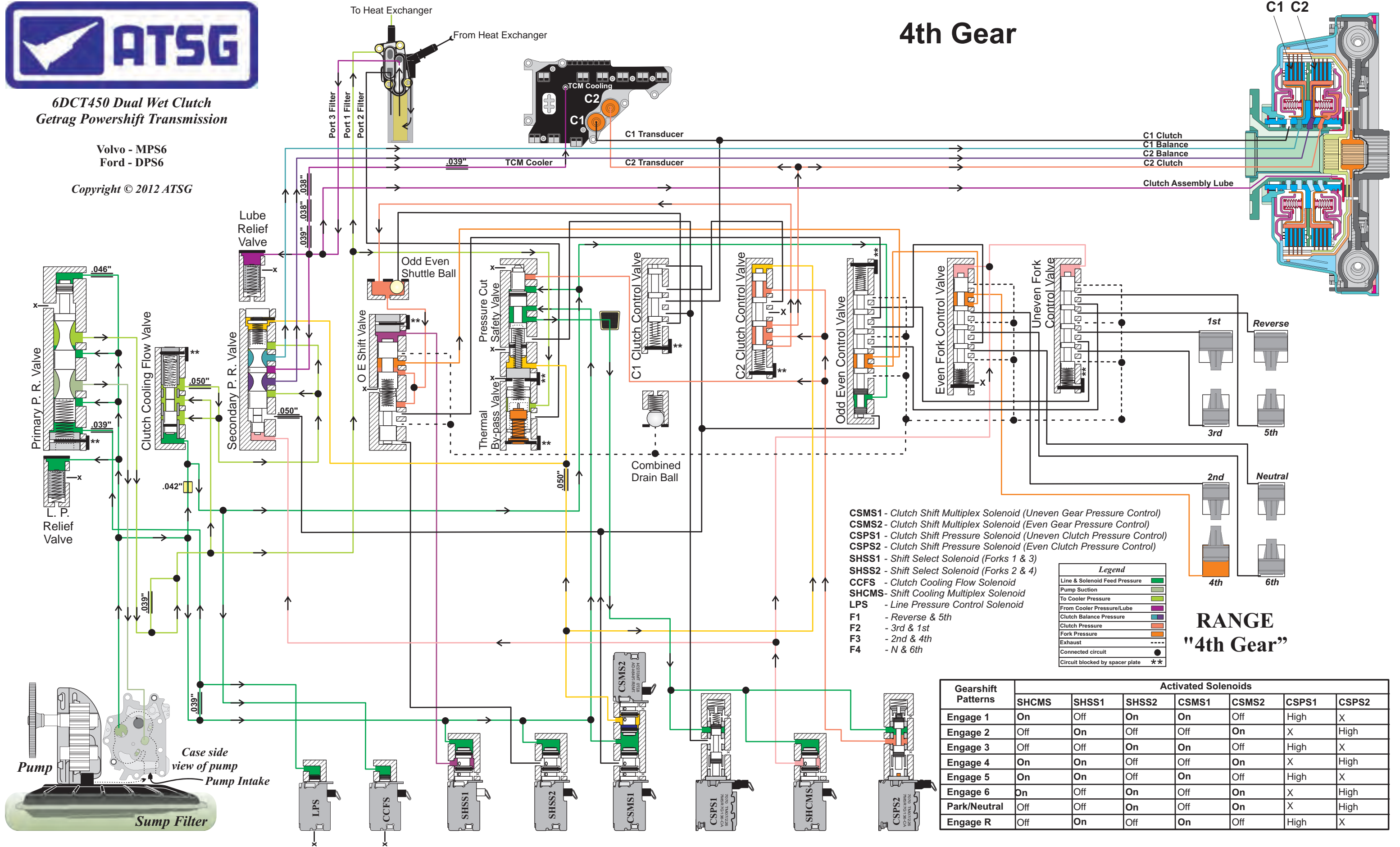

**RANGE  
"4th Gear"**

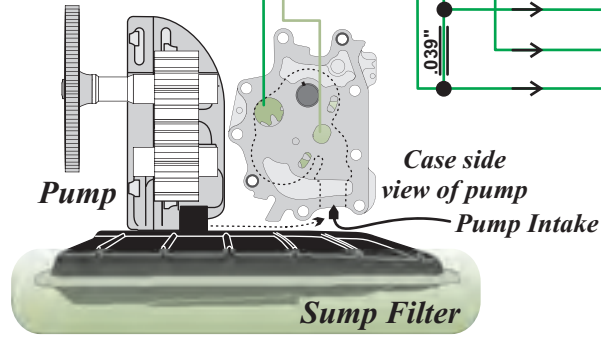
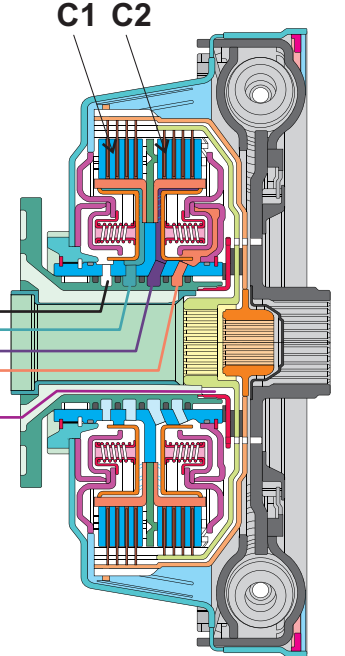



**6DCT450 Dual Wet Clutch  
Getrag Powershift Transmission**

Volvo - MPS6  
Ford - DPS6

Copyright © 2012 ATSG

**5th Gear**

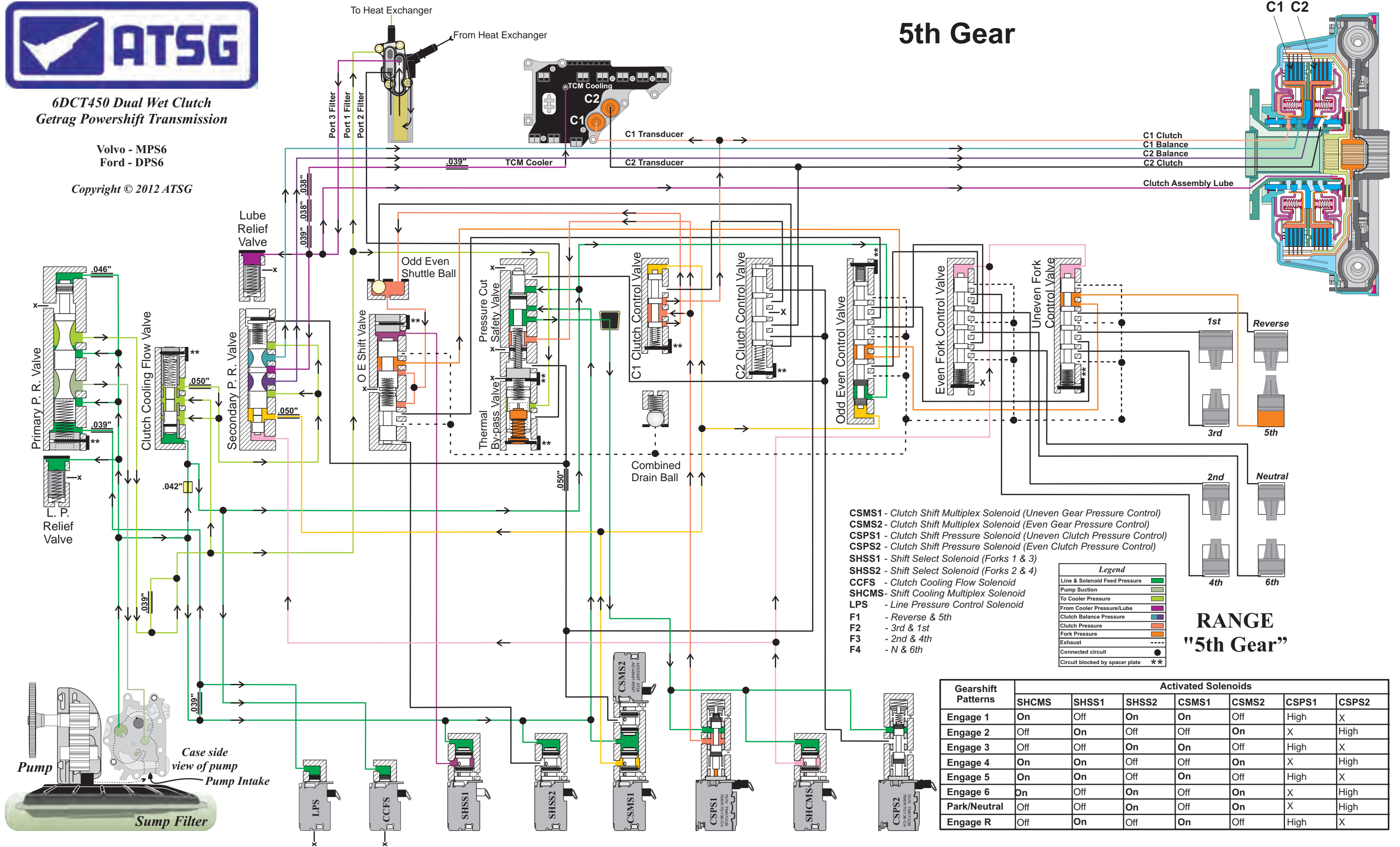

- CSMS1** - Clutch Shift Multiplex Solenoid (Uneven Gear Pressure Control)
- CSMS2** - Clutch Shift Multiplex Solenoid (Even Gear Pressure Control)
- CSPS1** - Clutch Shift Pressure Solenoid (Uneven Clutch Pressure Control)
- CSPS2** - Clutch Shift Pressure Solenoid (Even Clutch Pressure Control)
- SHSS1** - Shift Select Solenoid (Forks 1 & 3)
- SHSS2** - Shift Select Solenoid (Forks 2 & 4)
- CCFS** - Clutch Cooling Flow Solenoid
- SHCMS** - Shift Cooling Multiplex Solenoid
- LPS** - Line Pressure Control Solenoid
- F1** - Reverse & 5th
- F2** - 3rd & 1st
- F3** - 2nd & 4th
- F4** - N & 6th

**Legend**

Line & Solenoid Feed Pressure	Green
Pump Suction	Light Green
To Cooler Pressure	Light Blue
From Cooler Pressure/Lube	Purple
Clutch Balance Pressure	Blue
Clutch Pressure	Orange
Fork Pressure	Red
Exhaust	Black
Connected circuit	●
Circuit blocked by spacer plate	**

**RANGE  
"5th Gear"**

Gearshift Patterns	Activated Solenoids						
	SHCMS	SHSS1	SHSS2	CSMS1	CSMS2	CSPS1	CSPS2
Engage 1	On	Off	On	On	Off	High	X
Engage 2	Off	On	Off	Off	On	X	High
Engage 3	Off	Off	On	On	Off	High	X
Engage 4	On	On	Off	Off	On	X	High
Engage 5	On	On	Off	On	Off	High	X
Engage 6	On	Off	On	Off	On	X	High
Park/Neutral	Off	Off	On	Off	On	X	High
Engage R	Off	On	Off	On	Off	High	X

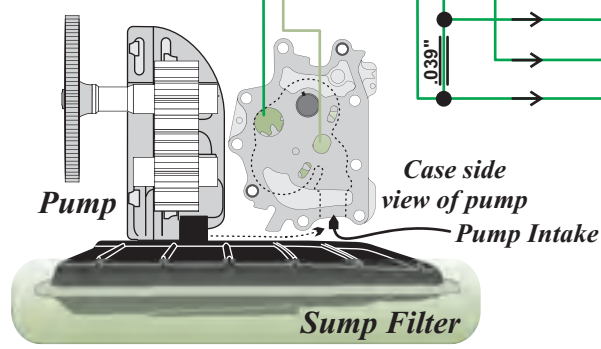





**6DCT450 Dual Wet Clutch  
Getrag Powershift Transmission**

Volvo - MPS6  
Ford - DPS6

Copyright © 2012 ATSG

**6th Gear**

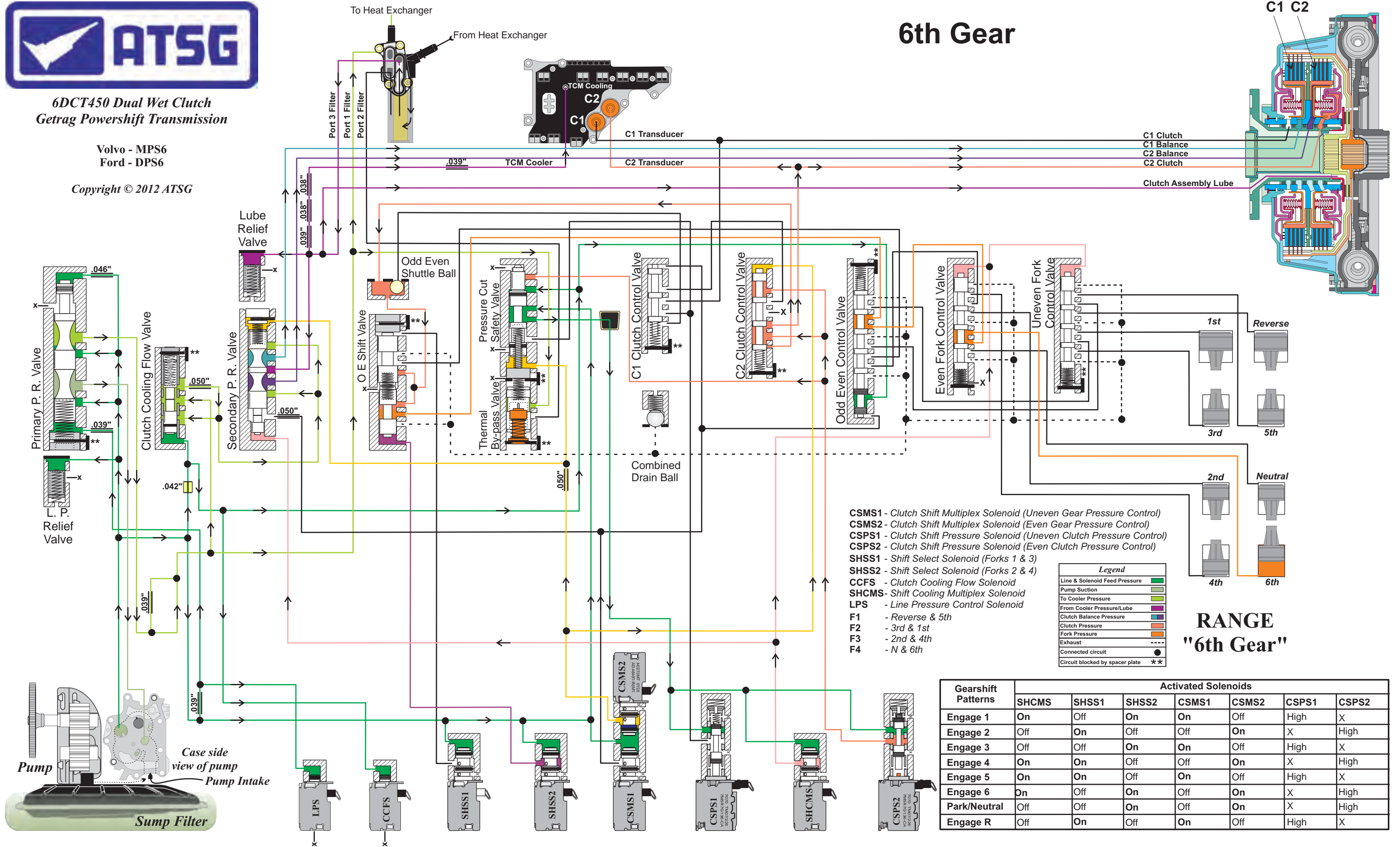

- CSMS1** - Clutch Shift Multiplex Solenoid (Uneven Gear Pressure Control)
- CSMS2** - Clutch Shift Multiplex Solenoid (Even Gear Pressure Control)
- CSPS1** - Clutch Shift Pressure Solenoid (Uneven Clutch Pressure Control)
- CSPS2** - Clutch Shift Pressure Solenoid (Even Clutch Pressure Control)
- SHSS1** - Shift Select Solenoid (Forks 1 & 3)
- SHSS2** - Shift Select Solenoid (Forks 2 & 4)
- CCFS** - Clutch Cooling Flow Solenoid
- SHCMS** - Shift Cooling Multiplex Solenoid
- LPS** - Line Pressure Control Solenoid
- F1** - Reverse & 5th
- F2** - 3rd & 1st
- F3** - 2nd & 4th
- F4** - N & 6th

**Legend**

Line & Solenoid Feed Pressure	Green
Pump Suction	Light Green
To Cooler Pressure	Light Blue
From Cooler Pressure/Lube	Purple
Clutch Balance Pressure	Blue
Clutch Pressure	Orange
Fork Pressure	Red
Exhaust	Black
Connected circuit	●
Circuit blocked by spacer plate	**

**RANGE  
"6th Gear"**

Gearshift Patterns	Activated Solenoids						
	SHCMS	SHSS1	SHSS2	CSMS1	CSMS2	CSPS1	CSPS2
Engage 1	On	Off	On	On	Off	High	X
Engage 2	Off	On	Off	Off	On	X	High
Engage 3	Off	Off	On	On	Off	High	X
Engage 4	On	On	Off	Off	On	X	High
Engage 5	On	On	Off	On	Off	High	X
Engage 6	On	Off	On	Off	On	X	High
Park/Neutral	Off	Off	On	Off	On	X	High
Engage R	Off	On	Off	On	Off	High	X

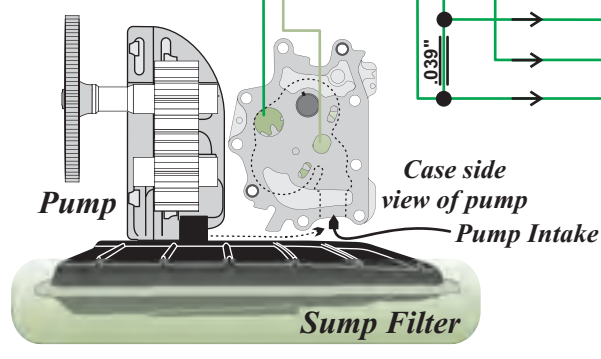



## VALVE BODY MAPPING DCT470

*PARTIAL HYDRAULIC  
SCHEMATIC FOR THE  
ODD FORK CONTROL VALVE*

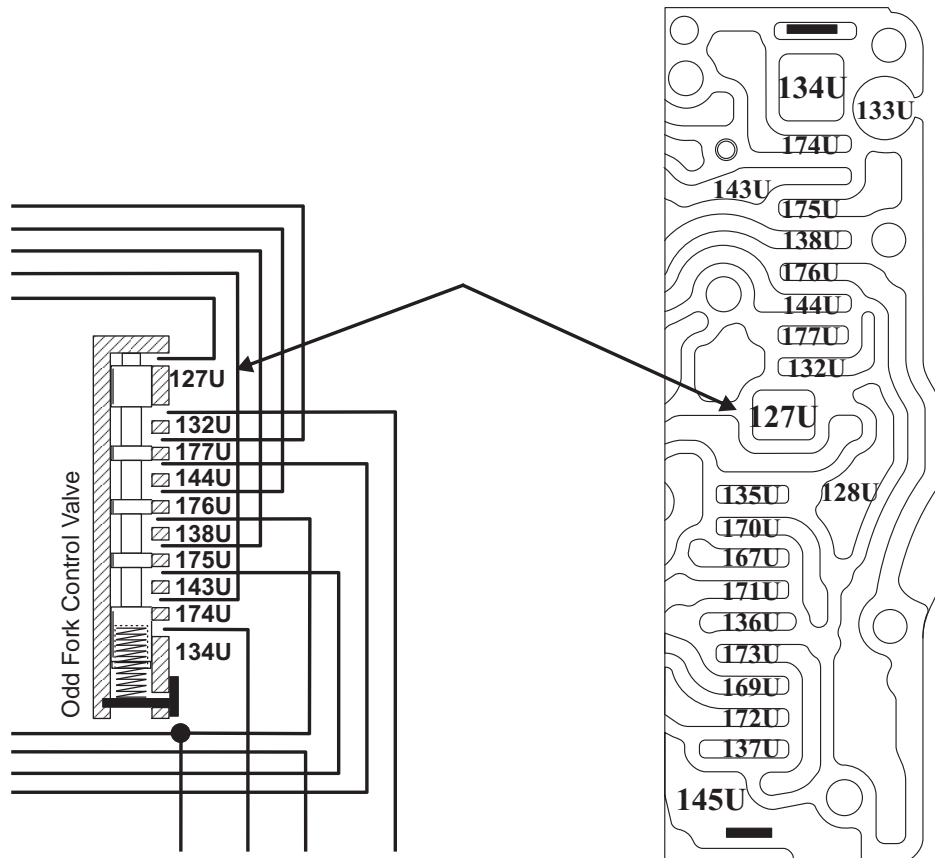

**100U SERIES FOR  
MAIN VALVE BODY CASTING**  
(Example of use is applied on all castings)

### HOW TO USE THIS MANUAL

All castings and spacer plates have been numbered so they can be identified in an oil diagram. **Example: Circuit 127U** passage is located in the Main Valve Body Upper side (100U Series). This passage can now be located in the partial oil circuit diagram shown above. Spacer plate orifice sizes and locations are also identified in the oil circuit diagram labeled Valve Body Mapping.

Copyright © ATSG 2012

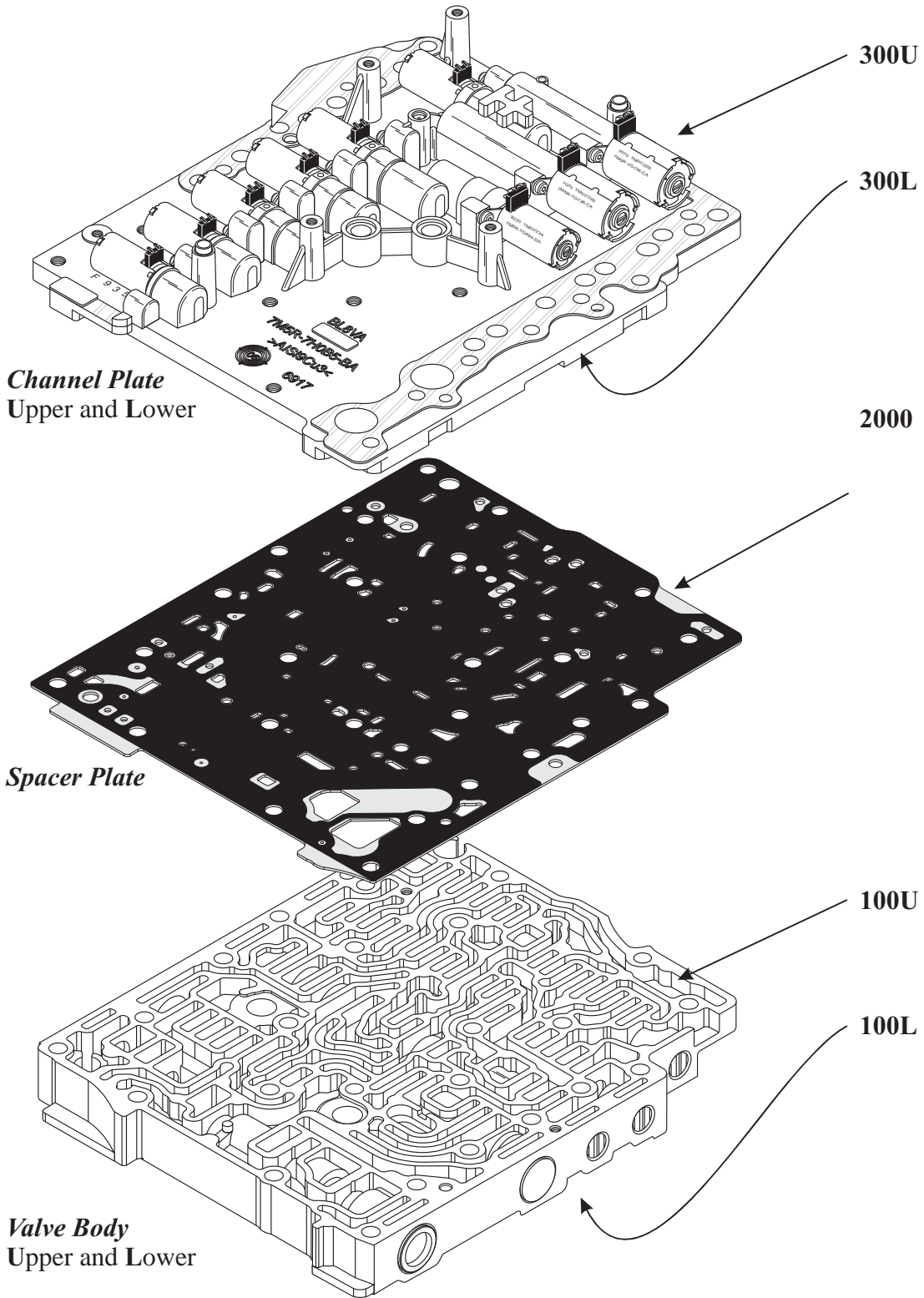

Copyright © ATSG 2012



# Technical Service Information

## MAIN VALVE BODY LOWER SIDE 100L Series

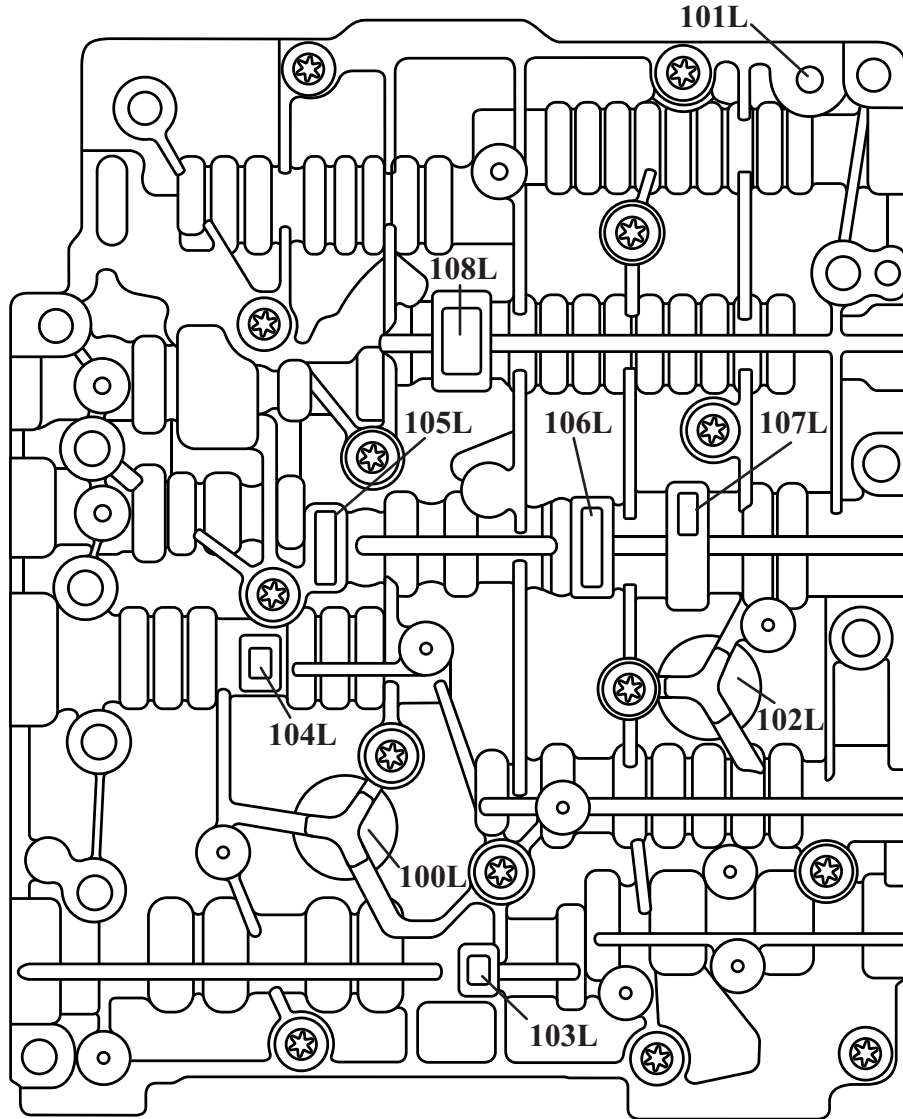

Copyright © ATSG 2012

# Technical Service Information

## MAIN VALVE BODY UPPER SIDE 100U Series

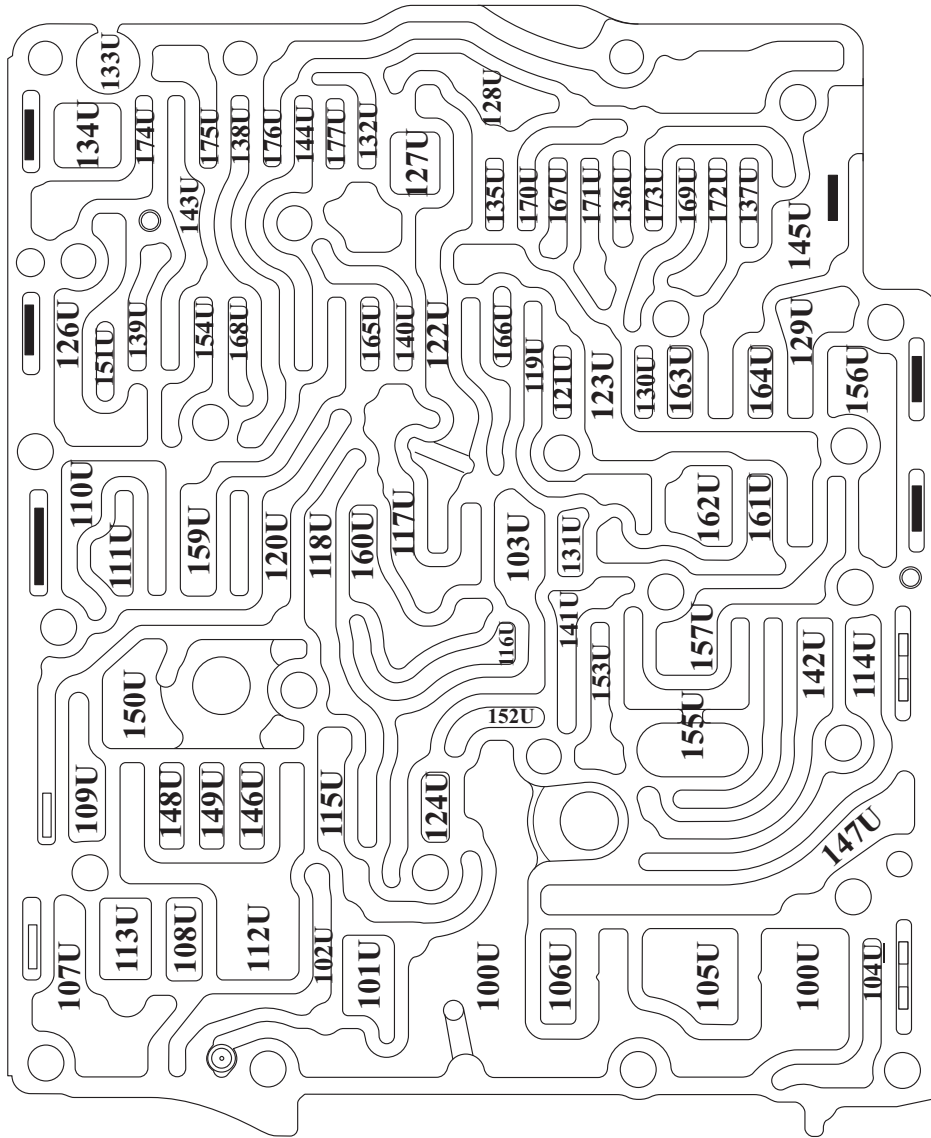

Copyright © ATSG 2012

# Technical Service Information

## MAIN SPACER PLATE 2000 Series

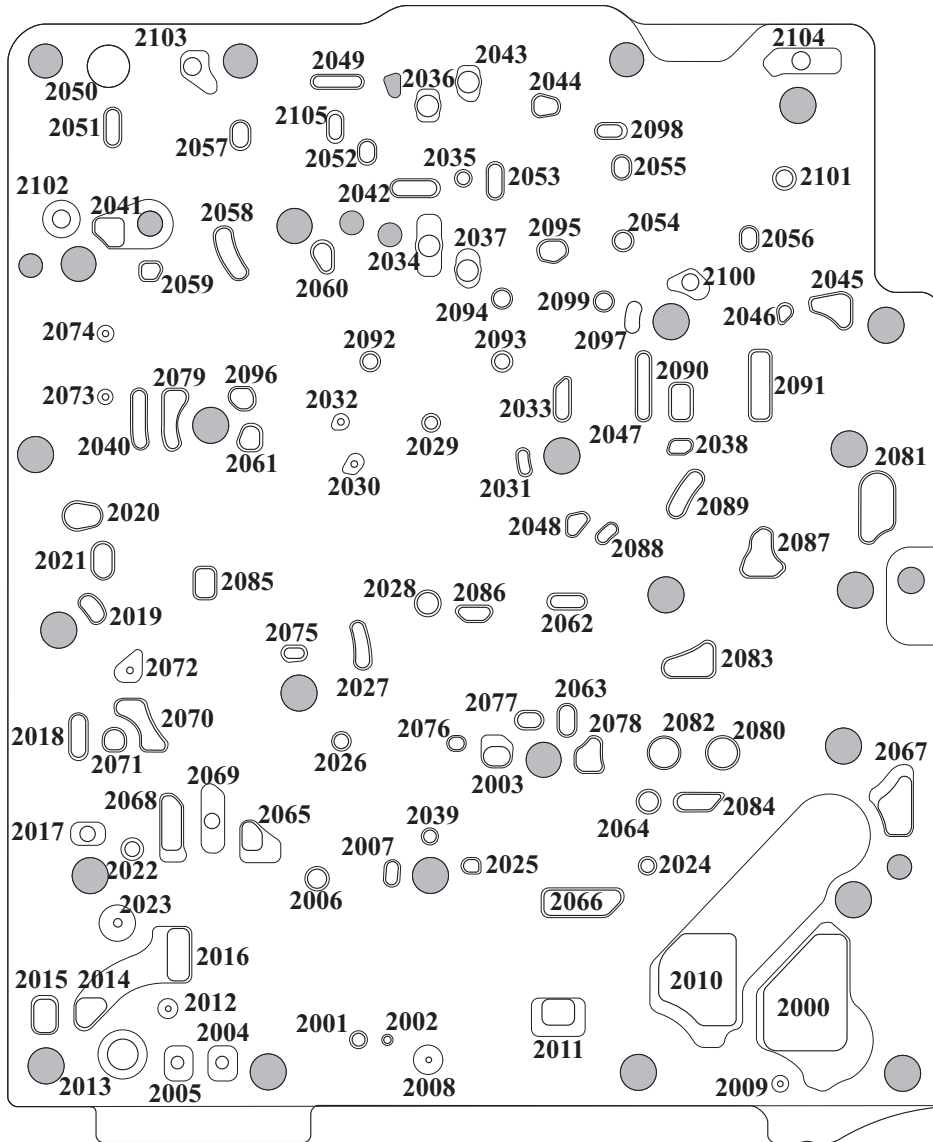

# Technical Service Information

## SOLENOID BODY/CHANNEL PLATE 300L Series

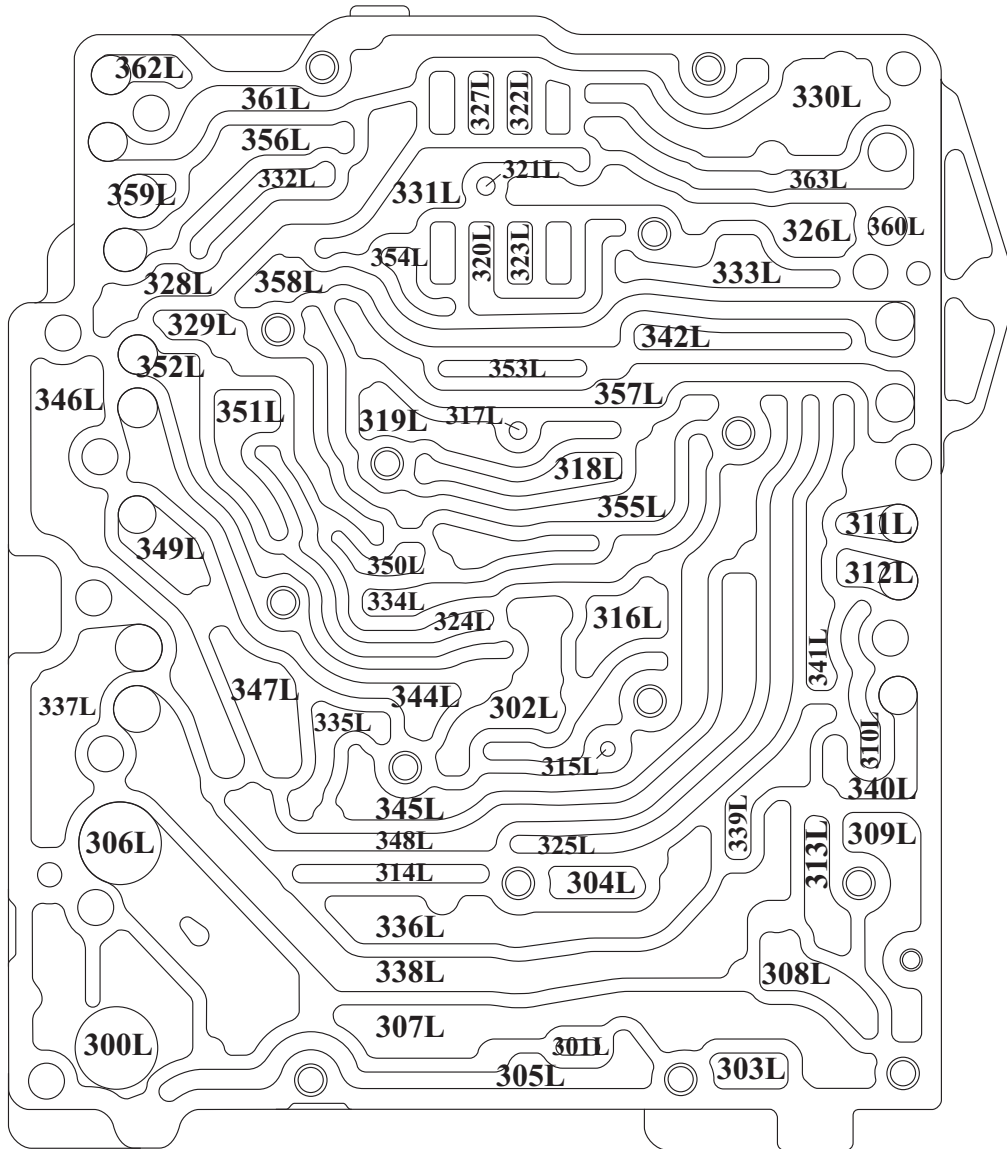

Copyright © ATSG 2012

# Technical Service Information

## SOLENOID BODY/CHANNEL PLATE 300U Series

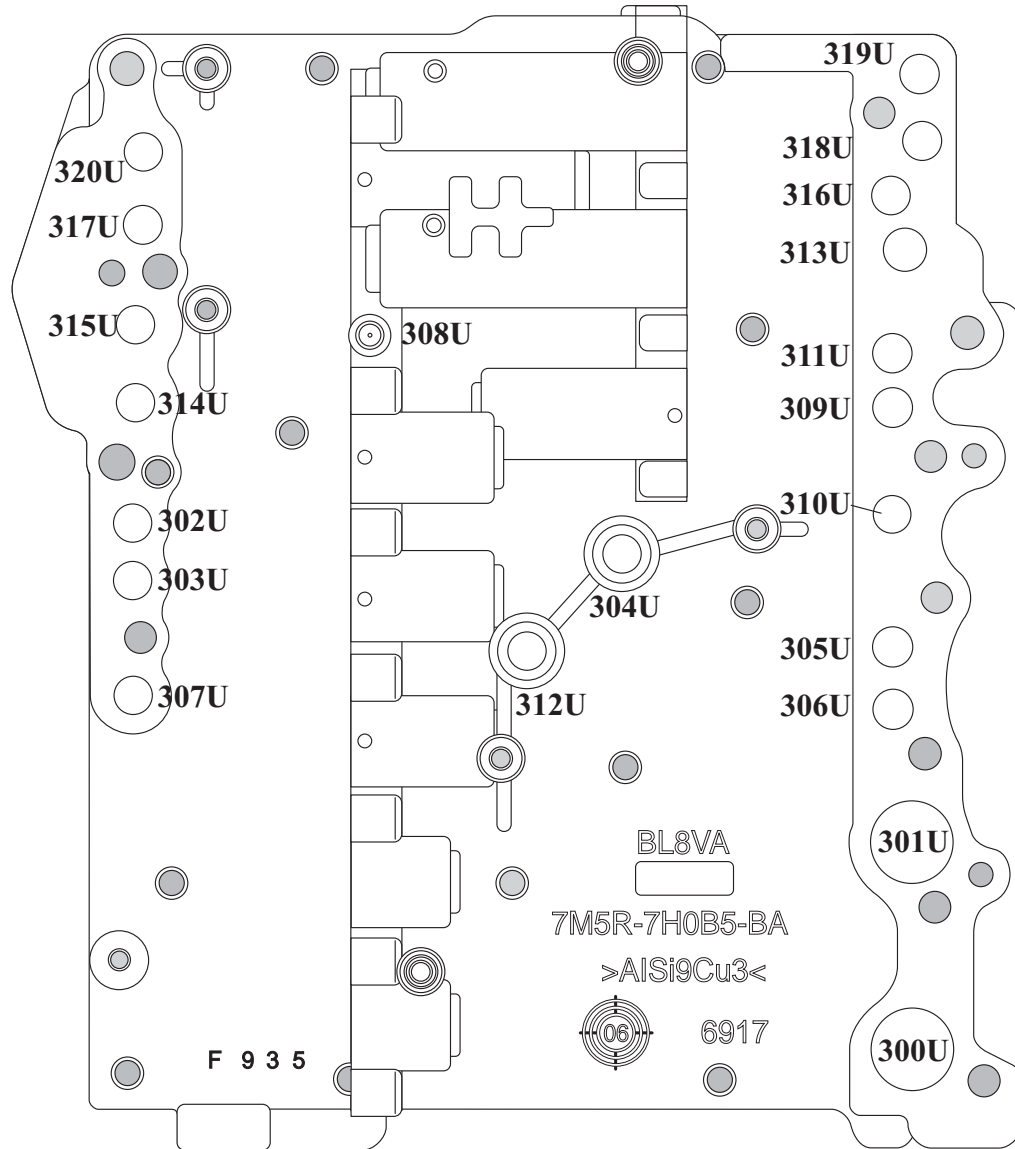

Copyright © ATSG 2012

# Technical Service Information

## CASE PASSAGE IDENTIFICATION CP Series

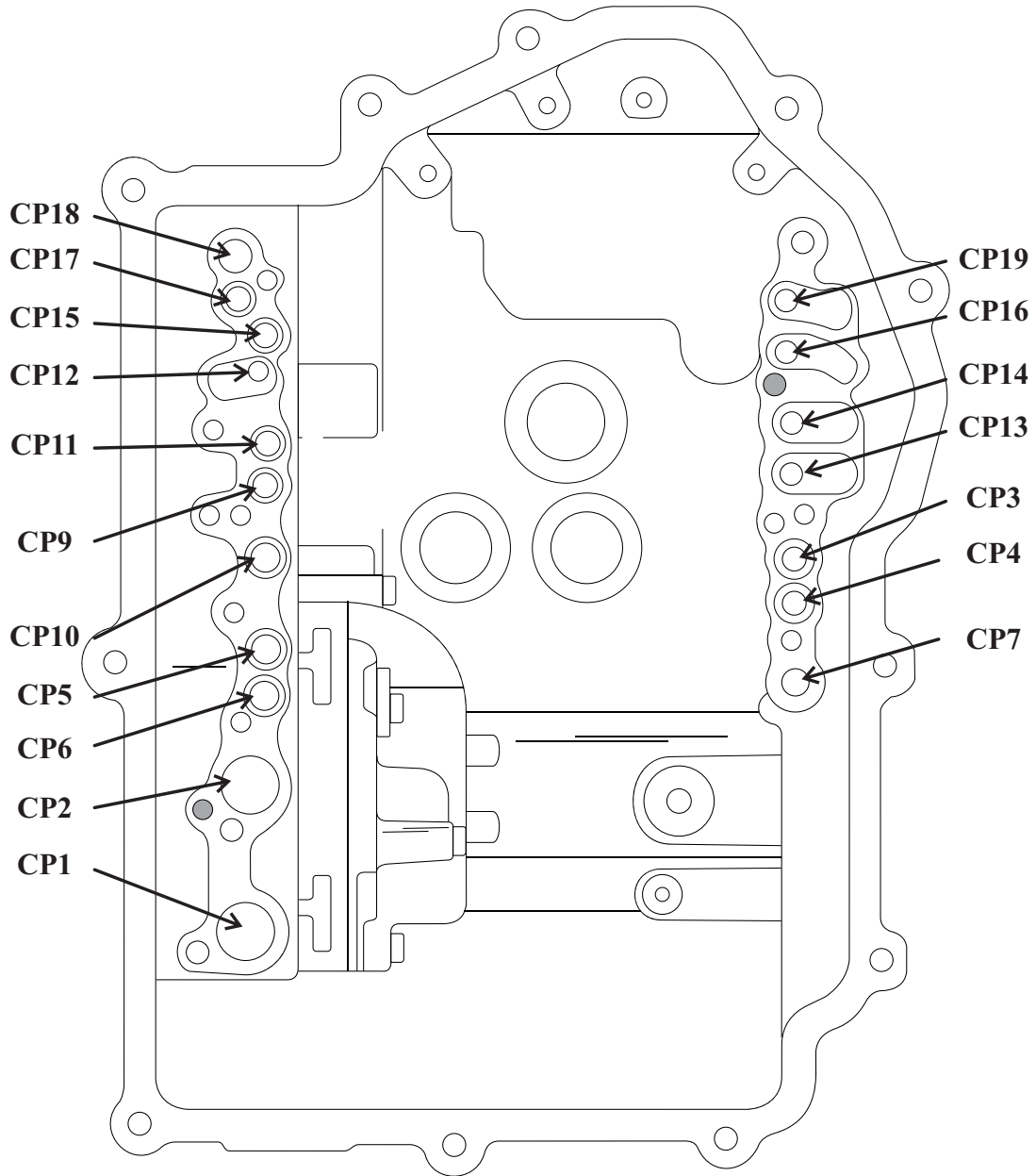

Copyright © ATSG 2012





**6DCT470 Dual Wet Clutch  
Getrag Transmission**

Mitsubishi - Twin Clutch SST  
W6DGA/SPS6

Copyright © 2012 ATSG

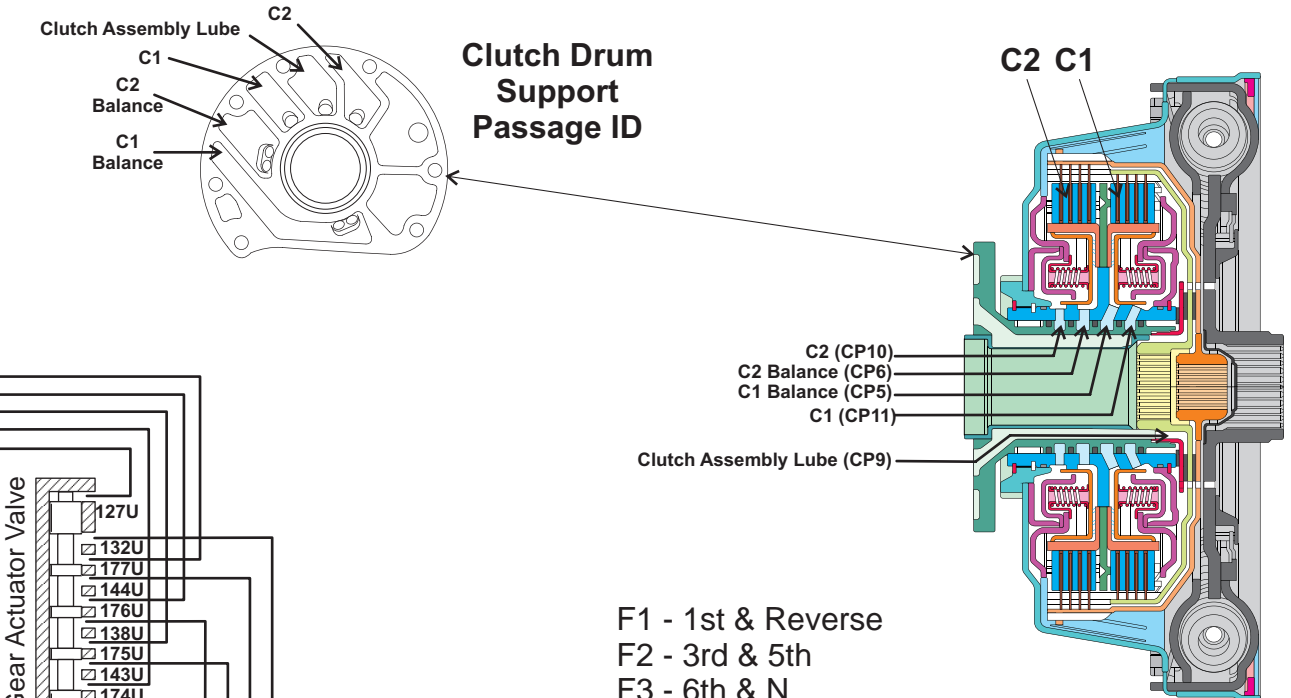
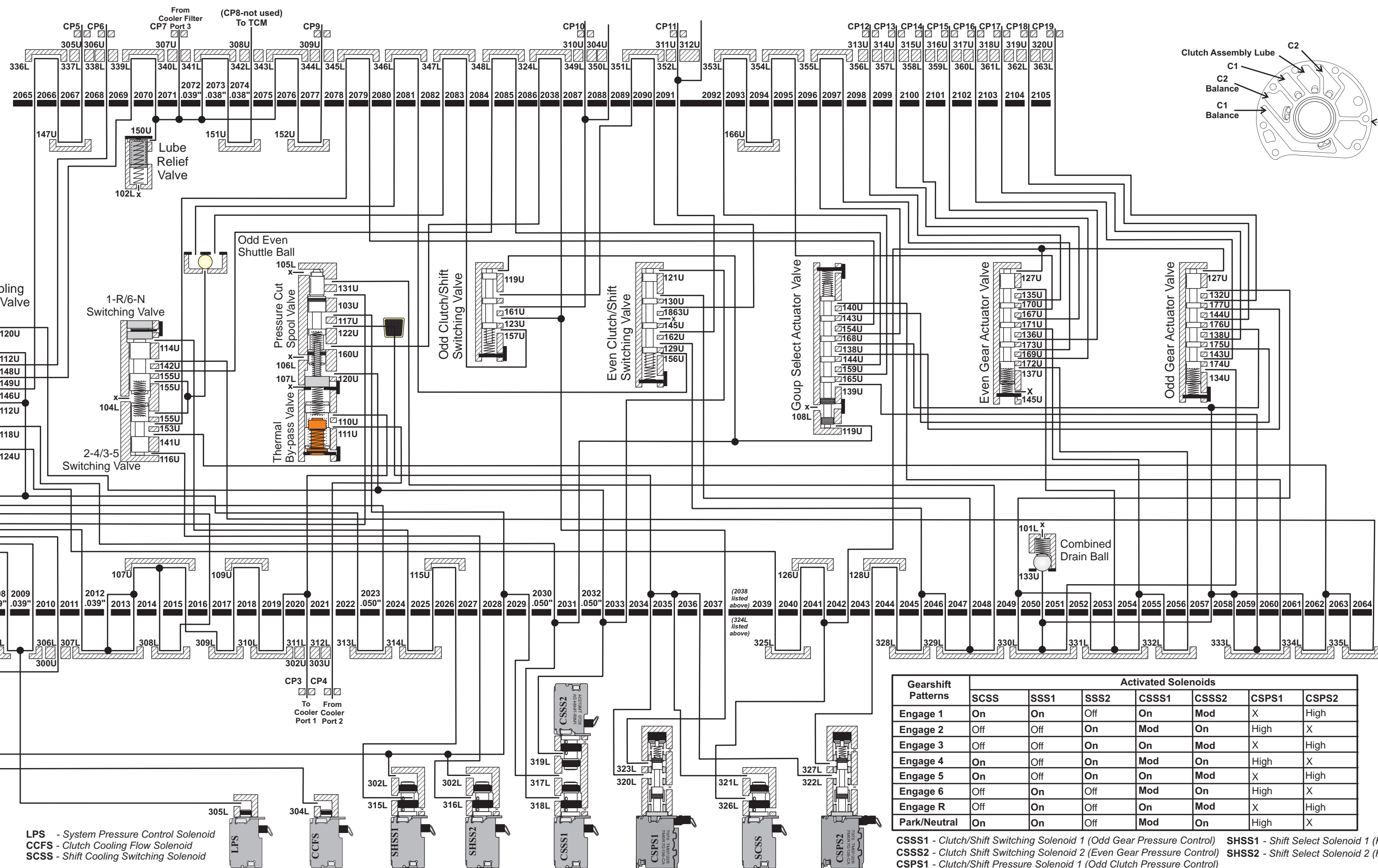

- F1 - 1st & Reverse
- F2 - 3rd & 5th
- F3 - 6th & N
- F4 - 2nd & 4th

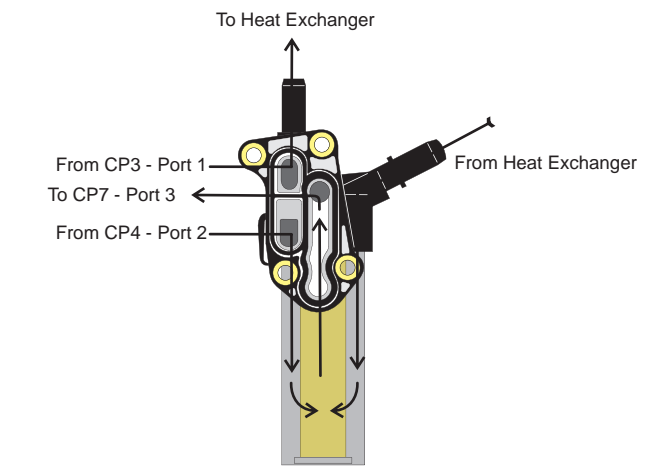
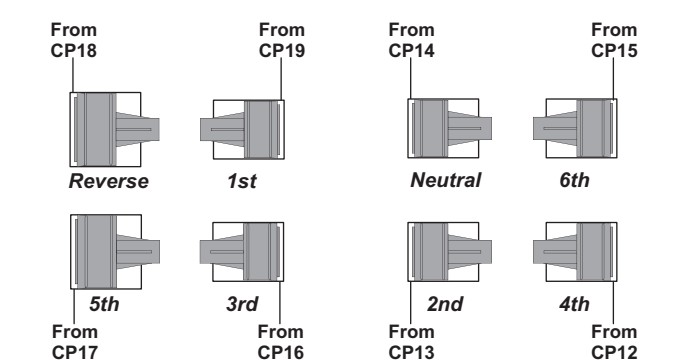

LPS - System Pressure Control Solenoid  
CCFS - Clutch Cooling Flow Solenoid  
SCSS - Shift Cooling Switching Solenoid

Gearshift Patterns	Activated Solenoids						
	SCSS	SSS1	SSS2	CSSS1	CSSS2	CPSP1	CPSP2
Engage 1	On	On	Off	On	Mod	X	High
Engage 2	Off	Off	On	Mod	On	High	X
Engage 3	Off	Off	On	On	Mod	X	High
Engage 4	On	Off	On	Mod	On	High	X
Engage 5	On	Off	On	On	Mod	X	High
Engage 6	Off	On	Off	Mod	On	High	X
Engage R	Off	On	Off	On	Mod	X	High
Park/Neutral	On	On	Off	Mod	On	High	X

CSSS1 - Clutch/Shift Switching Solenoid 1 (Odd Gear Pressure Control) SHSS1 - Shift Select Solenoid 1 (Forks 1 & 3)  
 CSSS2 - Clutch Shift Switching Solenoid 2 (Even Gear Pressure Control) SHSS2 - Shift Select Solenoid 2 (Forks 2 & 4)  
 CPSP1 - Clutch/Shift Pressure Solenoid 1 (Odd Clutch Pressure Control)  
 CPSP2 - Clutch/Shift Pressure Solenoid 2 (Even Clutch Pressure Control)

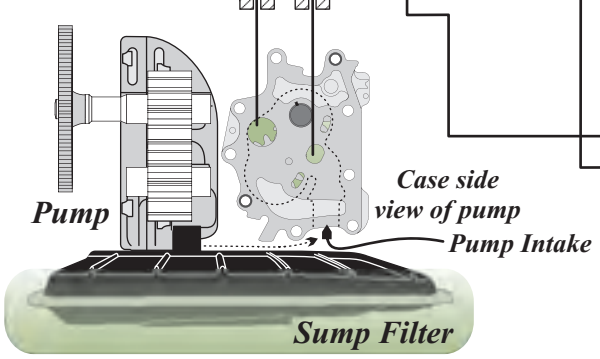
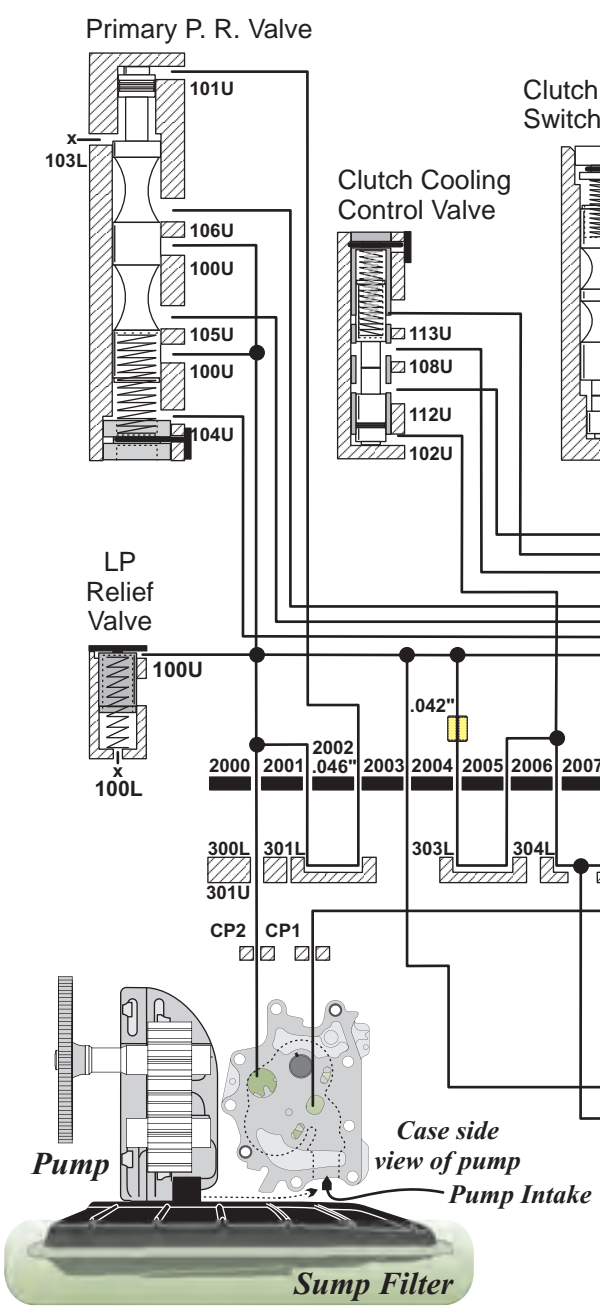



6DCT470 Dual Wet Clutch  
Getrag Transmission

Mitsubishi - Twin Clutch SST  
W6DGA/SPS6

Copyright © 2012 ATSG

Park/Neutral

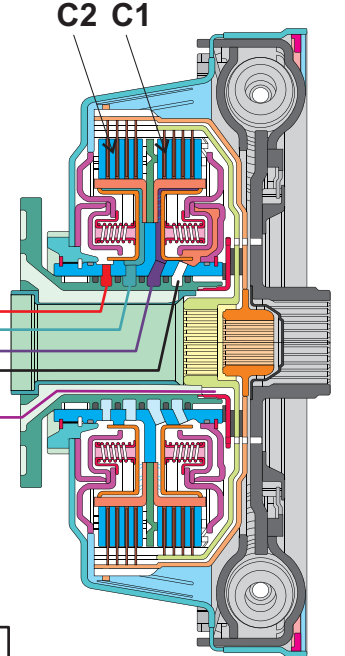
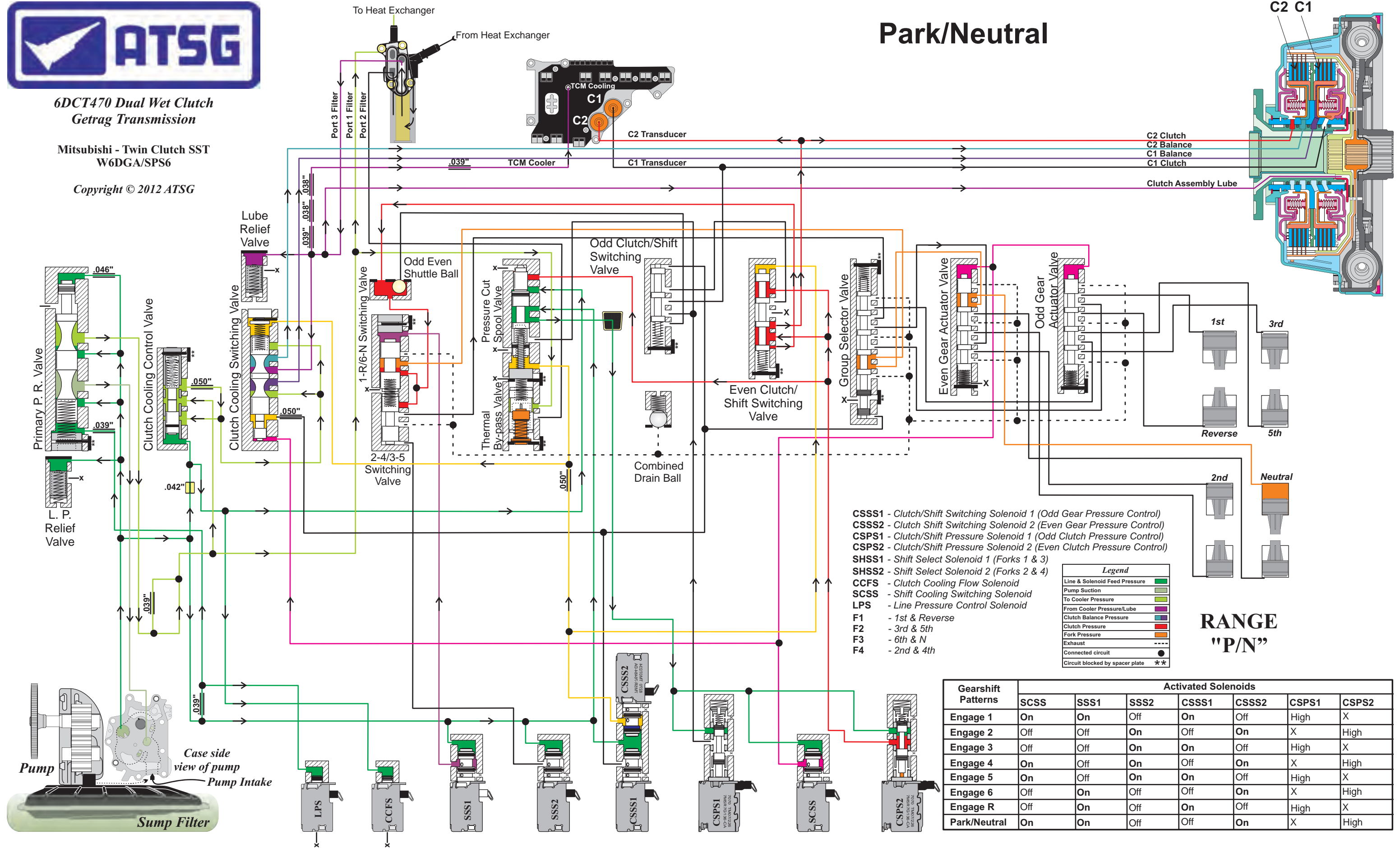

RANGE  
"P/N"

- CSSS1 - Clutch/Shift Switching Solenoid 1 (Odd Gear Pressure Control)
- CSSS2 - Clutch Shift Switching Solenoid 2 (Even Gear Pressure Control)
- CSPS1 - Clutch/Shift Pressure Solenoid 1 (Odd Clutch Pressure Control)
- CSPS2 - Clutch/Shift Pressure Solenoid 2 (Even Clutch Pressure Control)
- SHSS1 - Shift Select Solenoid 1 (Forks 1 & 3)
- SHSS2 - Shift Select Solenoid 2 (Forks 2 & 4)
- CCFS - Clutch Cooling Flow Solenoid
- SCSS - Shift Cooling Switching Solenoid
- LPS - Line Pressure Control Solenoid
- F1 - 1st & Reverse
- F2 - 3rd & 5th
- F3 - 6th & N
- F4 - 2nd & 4th

**Legend**

Line & Solenoid Feed Pressure	Green
Pump Suction	Light Green
To Cooler Pressure	Light Blue
From Cooler Pressure/Lube	Purple
Clutch Balance Pressure	Blue
Clutch Pressure	Red
Fork Pressure	Orange
Exhaust	Black
Connected circuit	●
Circuit blocked by spacer plate	**

Gearshift Patterns	Activated Solenoids						
	SCSS	SSS1	SSS2	CSSS1	CSSS2	CSPS1	CSPS2
Engage 1	On	On	Off	On	Off	High	X
Engage 2	Off	Off	On	Off	On	X	High
Engage 3	Off	Off	On	On	Off	High	X
Engage 4	On	Off	On	Off	On	X	High
Engage 5	On	Off	On	On	Off	High	X
Engage 6	Off	On	Off	Off	On	X	High
Engage R	Off	On	Off	On	Off	High	X
Park/Neutral	On	On	Off	Off	On	X	High

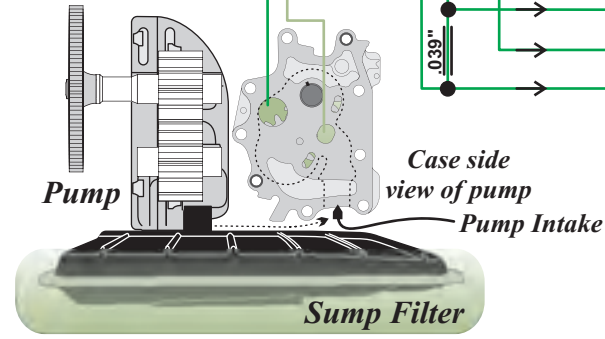





**6DCT470 Dual Wet Clutch  
Getrag Transmission**

**Mitsubishi - Twin Clutch SST  
W6DGA/SPS6**

Copyright © 2012 ATSG

# Reverse Gear

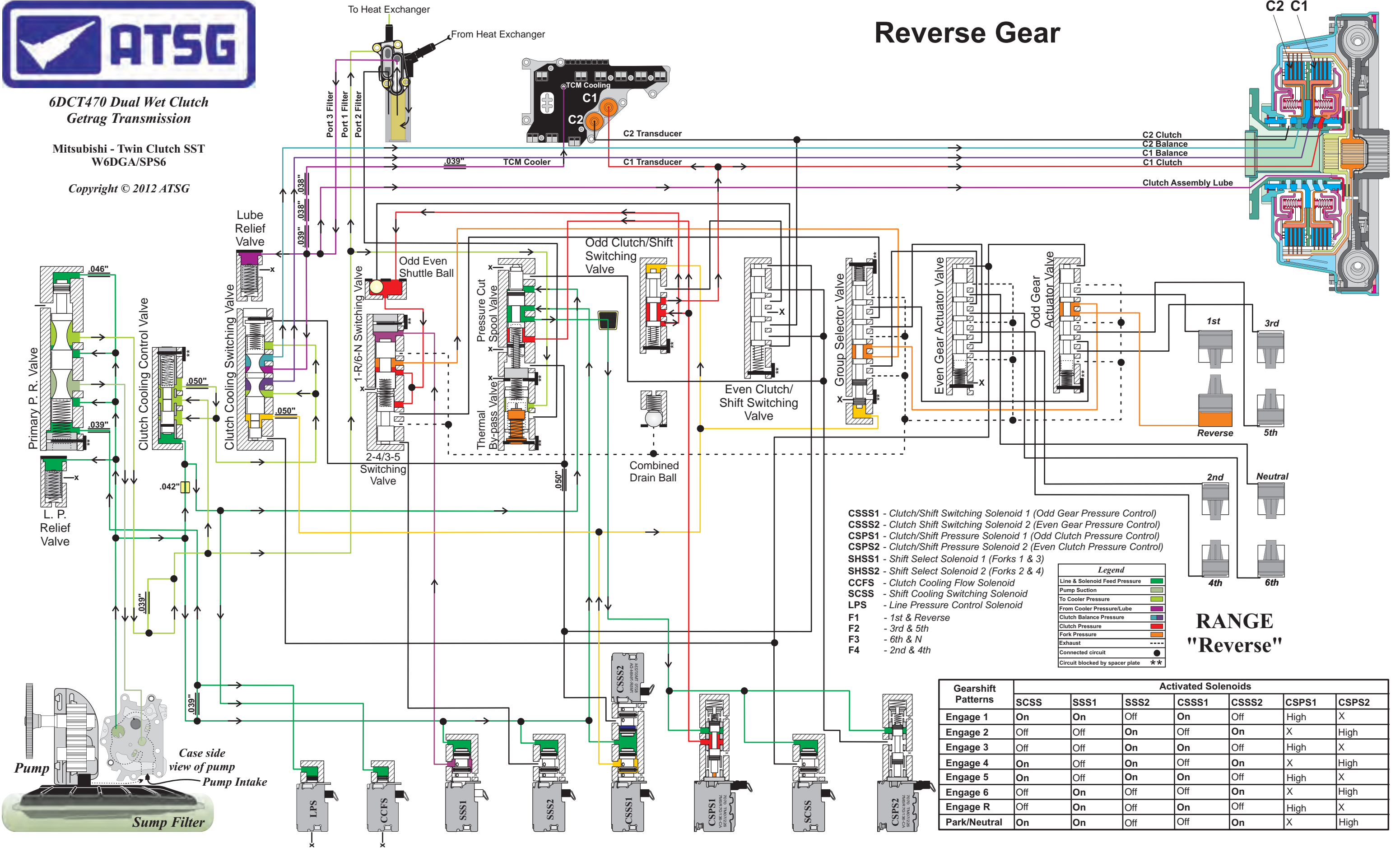

- CSSS1** - Clutch/Shift Switching Solenoid 1 (Odd Gear Pressure Control)
- CSSS2** - Clutch Shift Switching Solenoid 2 (Even Gear Pressure Control)
- CSPS1** - Clutch/Shift Pressure Solenoid 1 (Odd Clutch Pressure Control)
- CSPS2** - Clutch/Shift Pressure Solenoid 2 (Even Clutch Pressure Control)
- SHSS1** - Shift Select Solenoid 1 (Forks 1 & 3)
- SHSS2** - Shift Select Solenoid 2 (Forks 2 & 4)
- CCFS** - Clutch Cooling Flow Solenoid
- SCSS** - Shift Cooling Switching Solenoid
- LPS** - Line Pressure Control Solenoid
- F1** - 1st & Reverse
- F2** - 3rd & 5th
- F3** - 6th & N
- F4** - 2nd & 4th

**Legend**

Line & Solenoid Feed Pressure	Green
Pump Suction	Light Green
To Cooler Pressure	Light Blue
From Cooler Pressure/Lube	Purple
Clutch Balance Pressure	Blue
Clutch Pressure	Red
Fork Pressure	Orange
Exhaust	Black
Connected circuit	●
Circuit blocked by spacer plate	**

Gearshift Patterns	Activated Solenoids						
	SCSS	SSS1	SSS2	CSSS1	CSSS2	CSPS1	CSPS2
Engage 1	On	On	Off	On	Off	High	X
Engage 2	Off	Off	On	Off	On	X	High
Engage 3	Off	Off	On	On	Off	High	X
Engage 4	On	Off	On	Off	On	X	High
Engage 5	On	Off	On	On	Off	High	X
Engage 6	Off	On	Off	Off	On	X	High
Engage R	Off	On	Off	On	Off	High	X
Park/Neutral	On	On	Off	Off	On	X	High

**RANGE  
"Reverse"**



6DCT470 Dual Wet Clutch  
Getrag Transmission

Mitsubishi - Twin Clutch SST  
W6DGA/SPS6

Copyright © 2012 ATSG

First Gear

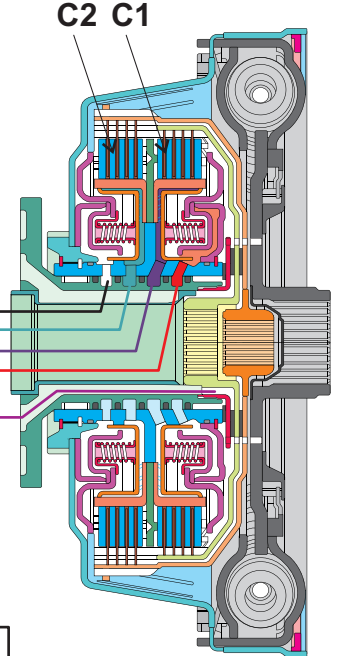
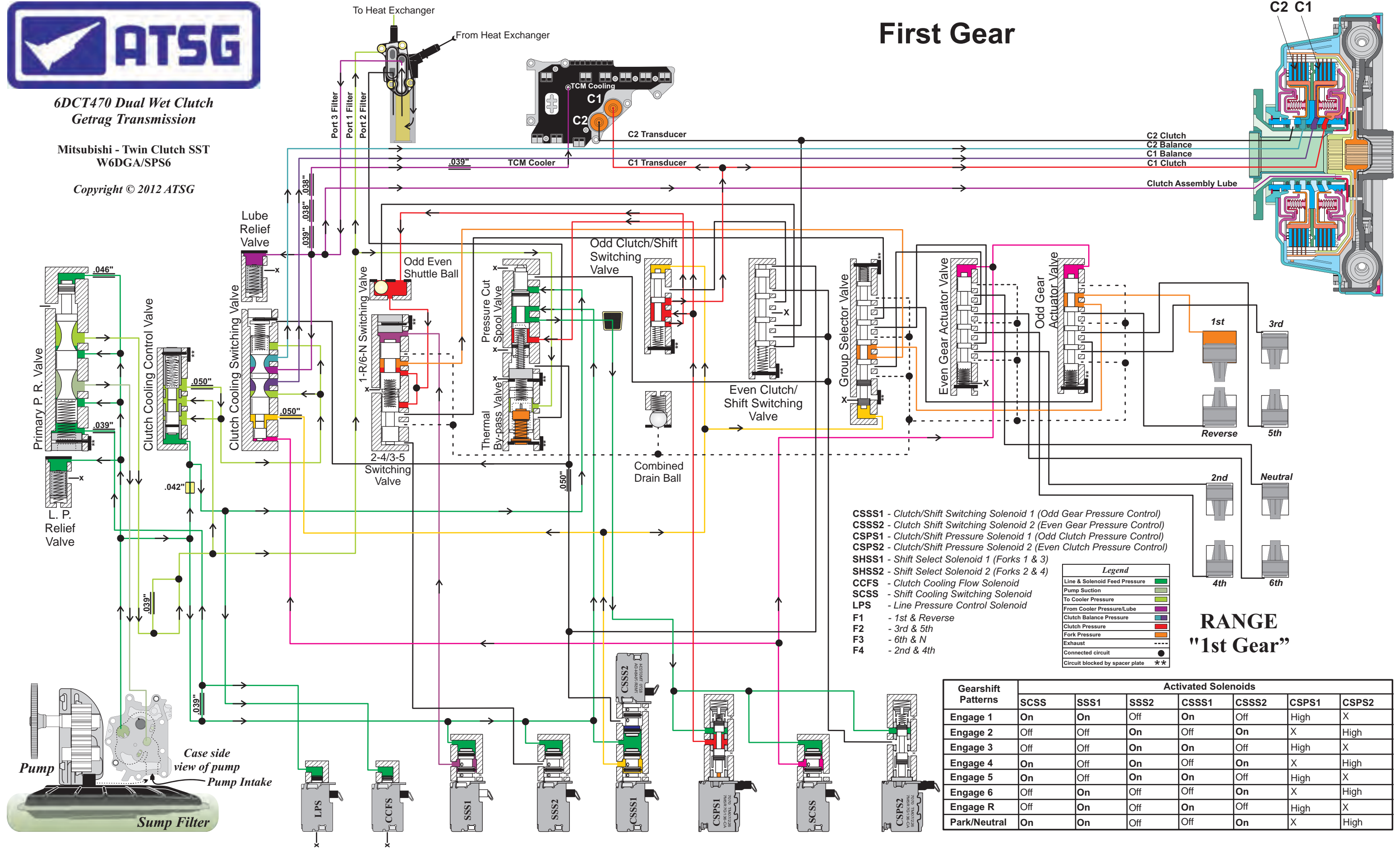

RANGE  
"1st Gear"

- CSSS1 - Clutch/Shift Switching Solenoid 1 (Odd Gear Pressure Control)
- CSSS2 - Clutch Shift Switching Solenoid 2 (Even Gear Pressure Control)
- CSPS1 - Clutch/Shift Pressure Solenoid 1 (Odd Clutch Pressure Control)
- CSPS2 - Clutch/Shift Pressure Solenoid 2 (Even Clutch Pressure Control)
- SHSS1 - Shift Select Solenoid 1 (Forks 1 & 3)
- SHSS2 - Shift Select Solenoid 2 (Forks 2 & 4)
- CCFS - Clutch Cooling Flow Solenoid
- SCSS - Shift Cooling Switching Solenoid
- LPS - Line Pressure Control Solenoid
- F1 - 1st & Reverse
- F2 - 3rd & 5th
- F3 - 6th & N
- F4 - 2nd & 4th

**Legend**

- Line & Solenoid Feed Pressure
- Pump Suction
- To Cooler Pressure
- From Cooler Pressure/Lube
- Clutch Balance Pressure
- Clutch Pressure
- Fork Pressure
- Exhaust
- Connected circuit
- Circuit blocked by spacer plate

Gearshift Patterns	Activated Solenoids						
	SCSS	SSS1	SSS2	CSSS1	CSSS2	CSPS1	CSPS2
Engage 1	On	On	Off	On	Off	High	X
Engage 2	Off	Off	On	Off	On	X	High
Engage 3	Off	Off	On	On	Off	High	X
Engage 4	On	Off	On	Off	On	X	High
Engage 5	On	Off	On	On	Off	High	X
Engage 6	Off	On	Off	Off	On	X	High
Engage R	Off	On	Off	On	Off	High	X
Park/Neutral	On	On	Off	Off	On	X	High

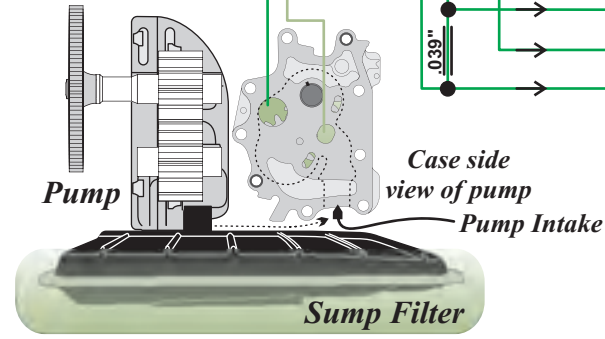



**6DCT470 Dual Wet Clutch  
Getrag Transmission**

**Mitsubishi - Twin Clutch SST  
W6DGA/SPS6**

Copyright © 2012 ATSG

# Second Gear

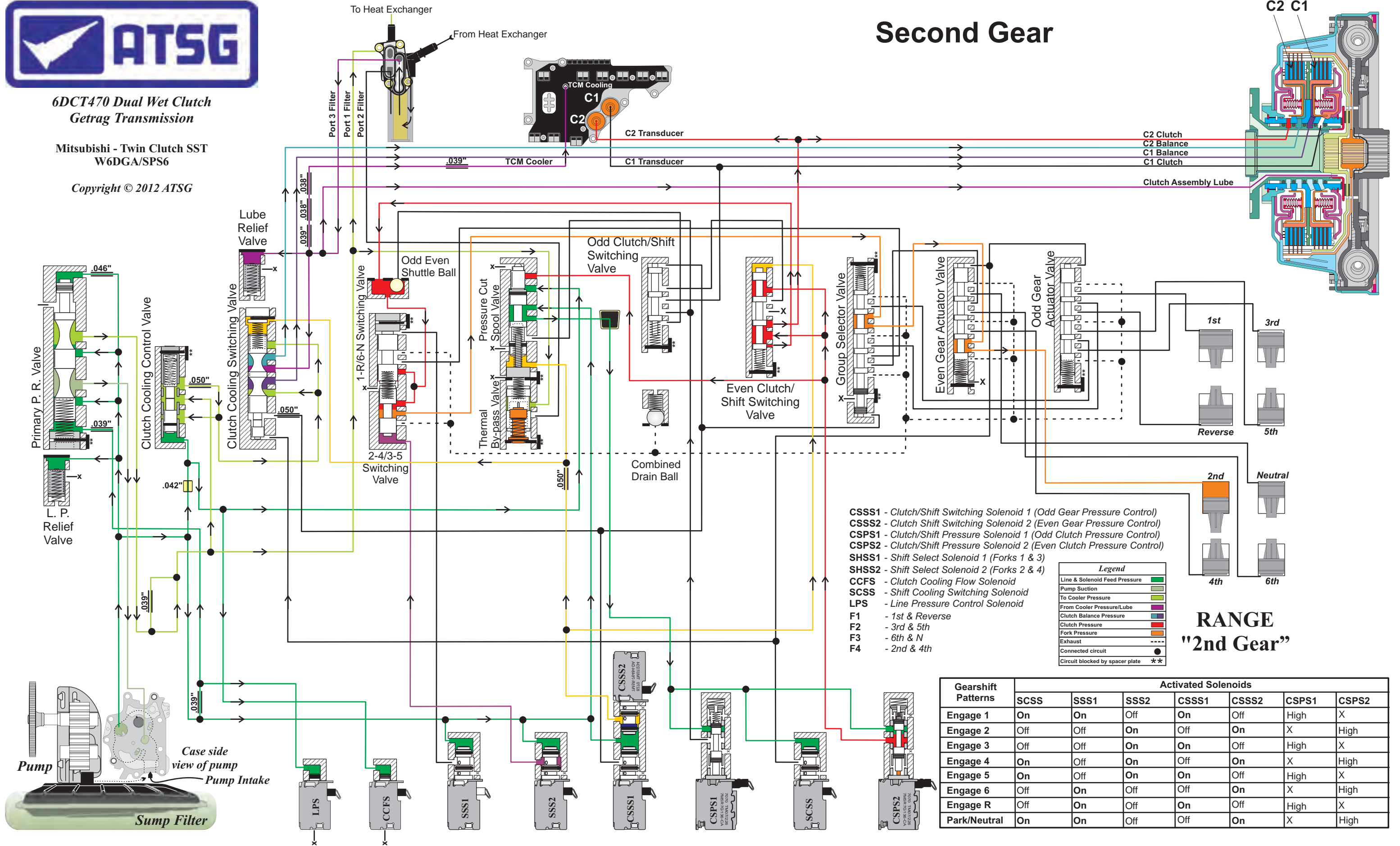

- CSSS1** - Clutch/Shift Switching Solenoid 1 (Odd Gear Pressure Control)
  - CSSS2** - Clutch Shift Switching Solenoid 2 (Even Gear Pressure Control)
  - CSPS1** - Clutch/Shift Pressure Solenoid 1 (Odd Clutch Pressure Control)
  - CSPS2** - Clutch/Shift Pressure Solenoid 2 (Even Clutch Pressure Control)
  - SHSS1** - Shift Select Solenoid 1 (Forks 1 & 3)
  - SHSS2** - Shift Select Solenoid 2 (Forks 2 & 4)
  - CCFS** - Clutch Cooling Flow Solenoid
  - SCSS** - Shift Cooling Switching Solenoid
  - LPS** - Line Pressure Control Solenoid
  - F1** - 1st & Reverse
  - F2** - 3rd & 5th
  - F3** - 6th & N
  - F4** - 2nd & 4th
- Legend**
- Line & Solenoid Feed Pressure
  - Pump Suction
  - To Cooler Pressure
  - From Cooler Pressure/Lube
  - Clutch Balance Pressure
  - Clutch Pressure
  - Fork Pressure
  - Exhaust
  - Connected circuit
  - Circuit blocked by spacer plate

Gearshift Patterns	Activated Solenoids						
	SCSS	SSS1	SSS2	CSSS1	CSSS2	CSPS1	CSPS2
Engage 1	On	On	Off	On	Off	High	X
Engage 2	Off	Off	On	Off	On	X	High
Engage 3	Off	Off	On	On	Off	High	X
Engage 4	On	Off	On	Off	On	X	High
Engage 5	On	Off	On	On	Off	High	X
Engage 6	Off	On	Off	Off	On	X	High
Engage R	Off	On	Off	On	Off	High	X
Park/Neutral	On	On	Off	Off	On	X	High

**RANGE  
"2nd Gear"**





6DCT470 Dual Wet Clutch  
Getrag Transmission

Mitsubishi - Twin Clutch SST  
W6DGA/SPS6

Copyright © 2012 ATSG

Third Gear

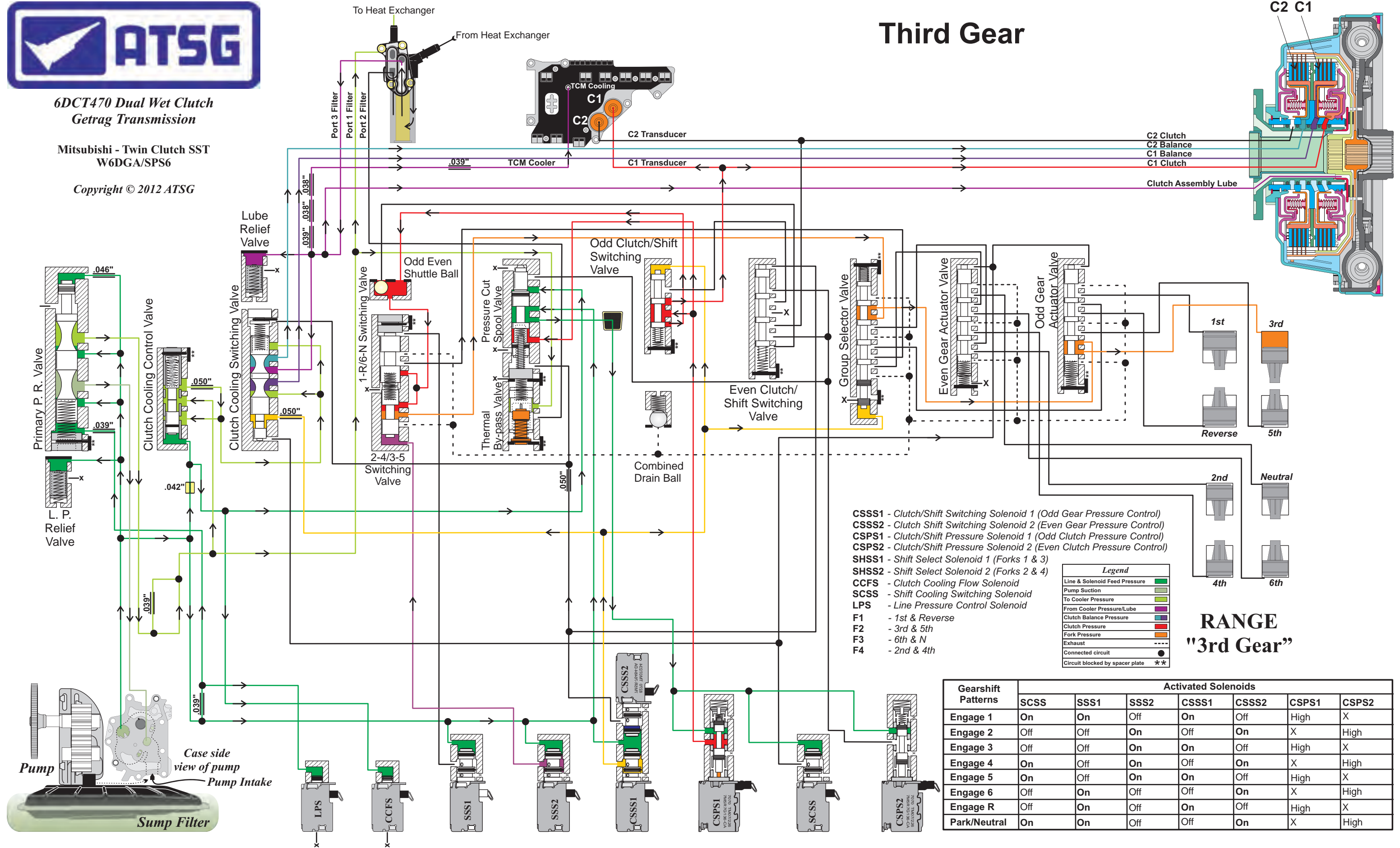

- CSSS1 - Clutch/Shift Switching Solenoid 1 (Odd Gear Pressure Control)
- CSSS2 - Clutch Shift Switching Solenoid 2 (Even Gear Pressure Control)
- CSPS1 - Clutch/Shift Pressure Solenoid 1 (Odd Clutch Pressure Control)
- CSPS2 - Clutch/Shift Pressure Solenoid 2 (Even Clutch Pressure Control)
- SHSS1 - Shift Select Solenoid 1 (Forks 1 & 3)
- SHSS2 - Shift Select Solenoid 2 (Forks 2 & 4)
- CCFS - Clutch Cooling Flow Solenoid
- SCSS - Shift Cooling Switching Solenoid
- LPS - Line Pressure Control Solenoid
- F1 - 1st & Reverse
- F2 - 3rd & 5th
- F3 - 6th & N
- F4 - 2nd & 4th

**Legend**

Line & Solenoid Feed Pressure	Green
Pump Suction	Light Green
To Cooler Pressure	Light Blue
From Cooler Pressure/Lube	Purple
Clutch Balance Pressure	Blue
Clutch Pressure	Red
Fork Pressure	Orange
Exhaust	Black
Connected circuit	●
Circuit blocked by spacer plate	**

**RANGE "3rd Gear"**

Gearshift Patterns	Activated Solenoids						
	SCSS	SSS1	SSS2	CSSS1	CSSS2	CSPS1	CSPS2
Engage 1	On	On	Off	On	Off	High	X
Engage 2	Off	Off	On	Off	On	X	High
Engage 3	Off	Off	On	On	Off	High	X
Engage 4	On	Off	On	Off	On	X	High
Engage 5	On	Off	On	On	Off	High	X
Engage 6	Off	On	Off	Off	On	X	High
Engage R	Off	On	Off	On	Off	High	X
Park/Neutral	On	On	Off	Off	On	X	High

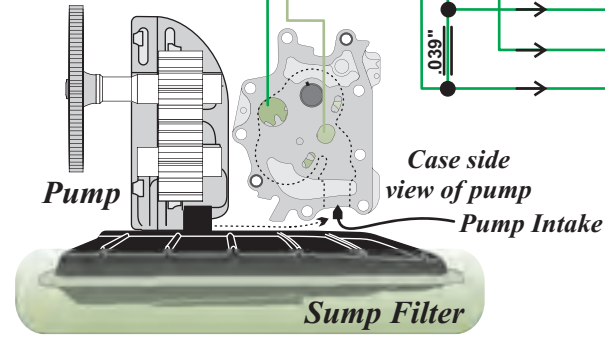





6DCT470 Dual Wet Clutch  
Getrag Transmission

Mitsubishi - Twin Clutch SST  
W6DGA/SPS6

Copyright © 2012 ATSG

# Fourth Gear

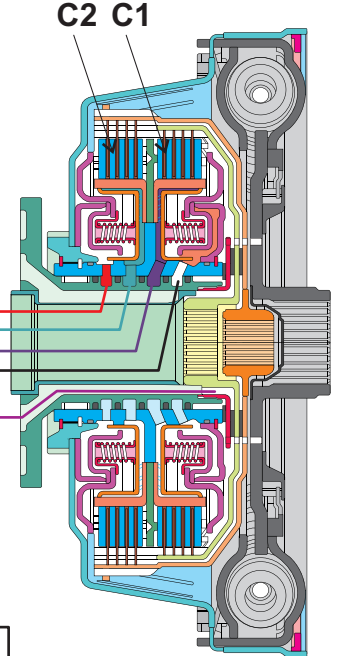
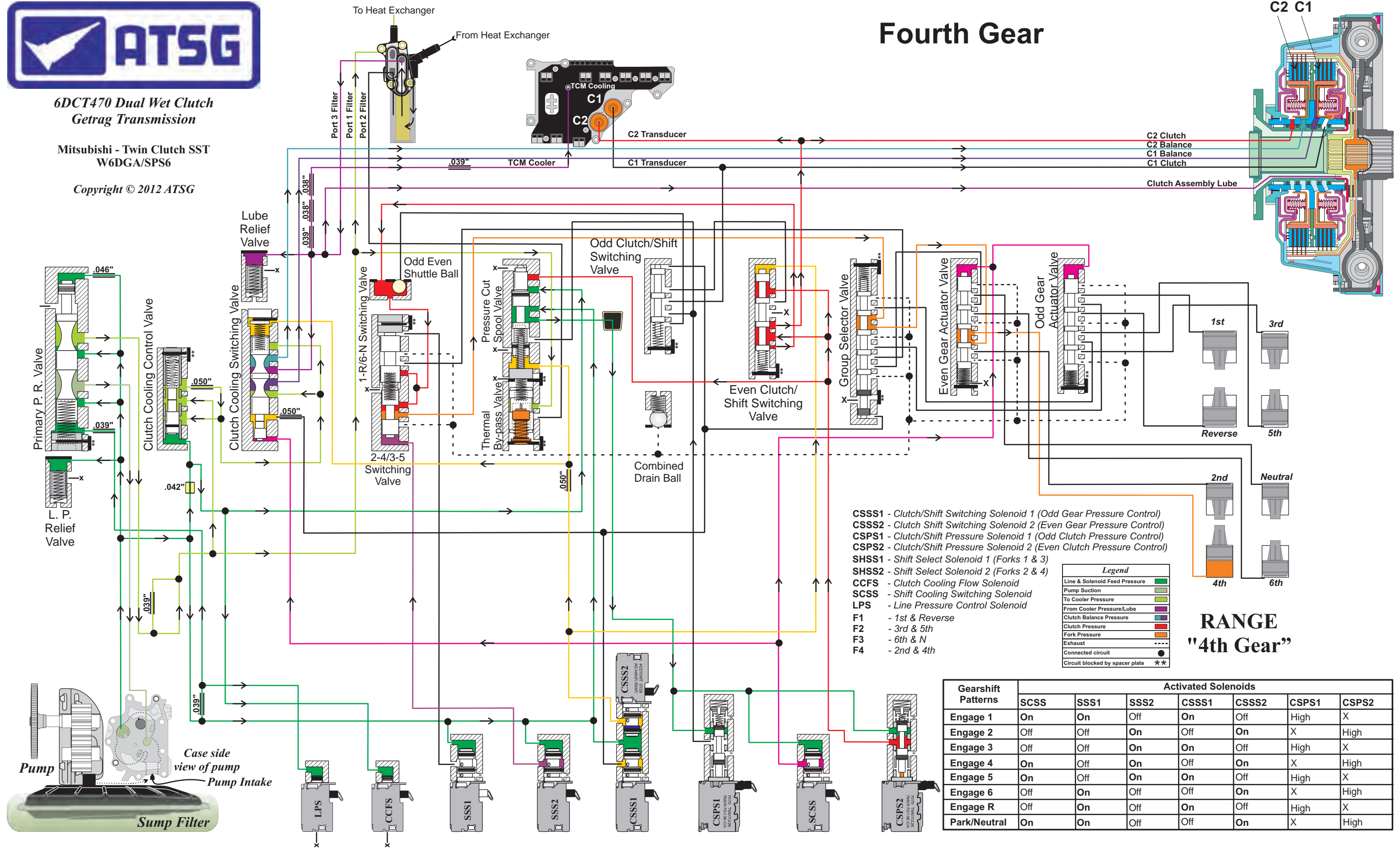

- CCSS1 - Clutch/Shift Switching Solenoid 1 (Odd Gear Pressure Control)
- CCSS2 - Clutch Shift Switching Solenoid 2 (Even Gear Pressure Control)
- CCPS1 - Clutch/Shift Pressure Solenoid 1 (Odd Clutch Pressure Control)
- CCPS2 - Clutch/Shift Pressure Solenoid 2 (Even Clutch Pressure Control)
- SHSS1 - Shift Select Solenoid 1 (Forks 1 & 3)
- SHSS2 - Shift Select Solenoid 2 (Forks 2 & 4)
- CCFS - Clutch Cooling Flow Solenoid
- SCSS - Shift Cooling Switching Solenoid
- LPS - Line Pressure Control Solenoid
- F1 - 1st & Reverse
- F2 - 3rd & 5th
- F3 - 6th & N
- F4 - 2nd & 4th

**Legend**

Line & Solenoid Feed Pressure	Green
Pump Suction	Light Green
To Cooler Pressure	Light Blue
From Cooler Pressure/Lube	Purple
Clutch Balance Pressure	Blue
Clutch Pressure	Red
Fork Pressure	Orange
Exhaust	Black
Connected circuit	●
Circuit blocked by spacer plate	**

## RANGE "4th Gear"

Gearshift Patterns	Activated Solenoids						
	SCSS	SSS1	SSS2	CCSS1	CCSS2	CCPS1	CCPS2
Engage 1	On	On	Off	On	Off	High	X
Engage 2	Off	Off	On	Off	On	X	High
Engage 3	Off	Off	On	On	Off	High	X
Engage 4	On	Off	On	Off	On	X	High
Engage 5	On	Off	On	On	Off	High	X
Engage 6	Off	On	Off	Off	On	X	High
Engage R	Off	On	Off	On	Off	High	X
Park/Neutral	On	On	Off	Off	On	X	High

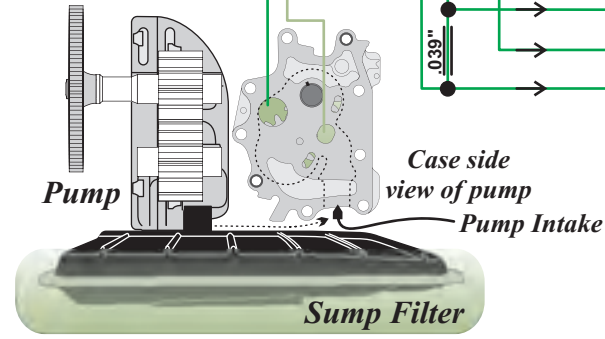



6DCT470 Dual Wet Clutch  
Getrag Transmission

Mitsubishi - Twin Clutch SST  
W6DGA/SPS6

Copyright © 2012 ATSG

Fifth Gear

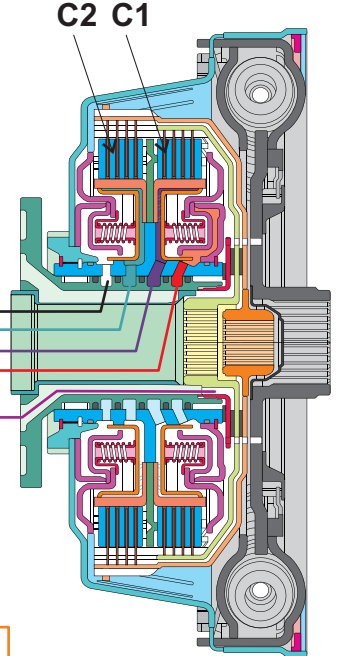
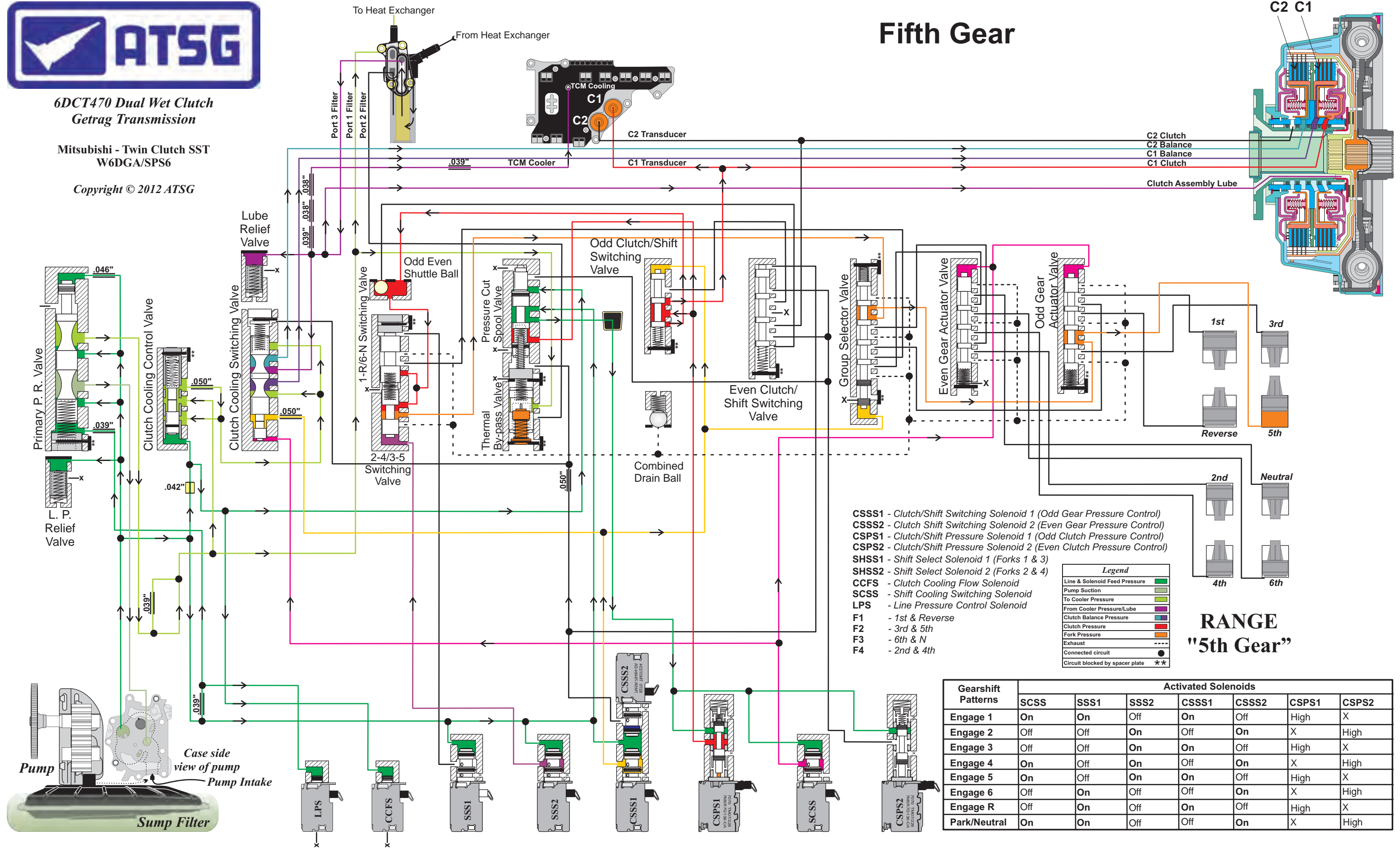

C2 Clutch  
C2 Balance  
C1 Balance  
C1 Clutch

Clutch Assembly Lube

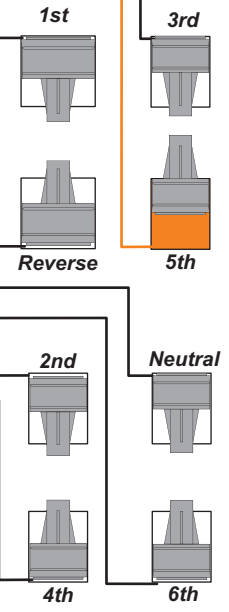

RANGE  
"5th Gear"

- CSSS1 - Clutch/Shift Switching Solenoid 1 (Odd Gear Pressure Control)
- CSSS2 - Clutch Shift Switching Solenoid 2 (Even Gear Pressure Control)
- CPSP1 - Clutch/Shift Pressure Solenoid 1 (Odd Clutch Pressure Control)
- CPSP2 - Clutch/Shift Pressure Solenoid 2 (Even Clutch Pressure Control)
- SHSS1 - Shift Select Solenoid 1 (Forks 1 & 3)
- SHSS2 - Shift Select Solenoid 2 (Forks 2 & 4)
- CCFS - Clutch Cooling Flow Solenoid
- SCSS - Shift Cooling Switching Solenoid
- LPS - Line Pressure Control Solenoid
- F1 - 1st & Reverse
- F2 - 3rd & 5th
- F3 - 6th & N
- F4 - 2nd & 4th

**Legend**

- Line & Solenoid Feed Pressure
- Pump Suction
- To Cooler Pressure
- From Cooler Pressure/Lube
- Clutch Balance Pressure
- Clutch Pressure
- Fork Pressure
- Exhaust
- Connected circuit
- Circuit blocked by spacer plate

Gearshift Patterns	Activated Solenoids						
	SCSS	SSS1	SSS2	CSSS1	CSSS2	CPSP1	CPSP2
Engage 1	On	On	Off	On	Off	High	X
Engage 2	Off	Off	On	Off	On	X	High
Engage 3	Off	Off	On	On	Off	High	X
Engage 4	On	Off	On	Off	On	X	High
Engage 5	On	Off	On	On	Off	High	X
Engage 6	Off	On	Off	Off	On	X	High
Engage R	Off	On	Off	On	Off	High	X
Park/Neutral	On	On	Off	Off	On	X	High



**6DCT470 Dual Wet Clutch  
Getrag Transmission**

Mitsubishi - Twin Clutch SST  
W6DGA/SPS6

Copyright © 2012 ATSG

**Sixth Gear**

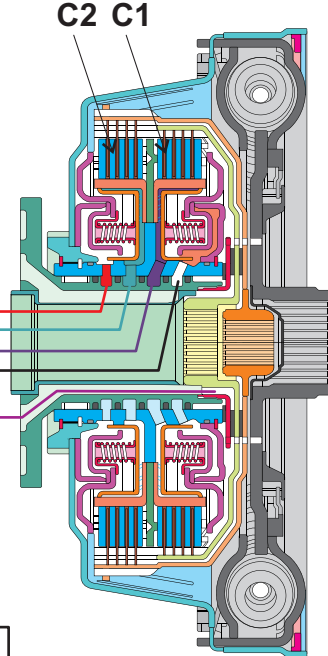
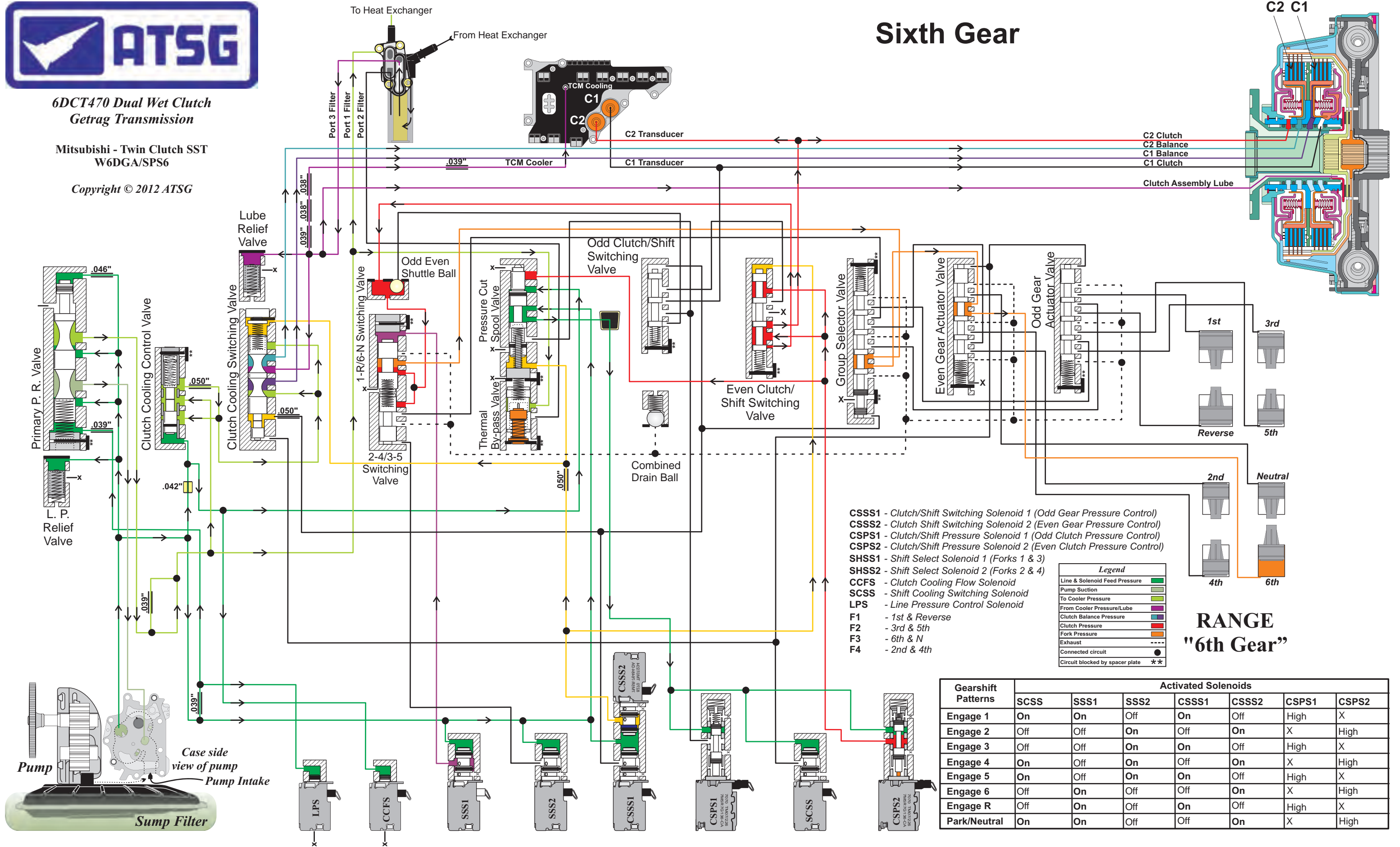

**RANGE  
"6th Gear"**

- CSSS1** - Clutch/Shift Switching Solenoid 1 (Odd Gear Pressure Control)
- CSSS2** - Clutch Shift Switching Solenoid 2 (Even Gear Pressure Control)
- CSPS1** - Clutch/Shift Pressure Solenoid 1 (Odd Clutch Pressure Control)
- CSPS2** - Clutch/Shift Pressure Solenoid 2 (Even Clutch Pressure Control)
- SHSS1** - Shift Select Solenoid 1 (Forks 1 & 3)
- SHSS2** - Shift Select Solenoid 2 (Forks 2 & 4)
- CCFS** - Clutch Cooling Flow Solenoid
- SCSS** - Shift Cooling Switching Solenoid
- LPS** - Line Pressure Control Solenoid
- F1** - 1st & Reverse
- F2** - 3rd & 5th
- F3** - 6th & N
- F4** - 2nd & 4th

**Legend**

Line & Solenoid Feed Pressure	Green
Pump Suction	Light Green
To Cooler Pressure	Light Blue
From Cooler Pressure/Lube	Purple
Clutch Balance Pressure	Blue
Clutch Pressure	Red
Fork Pressure	Orange
Exhaust	Black
Connected circuit	●
Circuit blocked by spacer plate	**

Gearshift Patterns	Activated Solenoids						
	SCSS	SSS1	SSS2	CSSS1	CSSS2	CSPS1	CSPS2
Engage 1	On	On	Off	On	Off	High	X
Engage 2	Off	Off	On	Off	On	X	High
Engage 3	Off	Off	On	On	Off	High	X
Engage 4	On	Off	On	Off	On	X	High
Engage 5	On	Off	On	On	Off	High	X
Engage 6	Off	On	Off	Off	On	X	High
Engage R	Off	On	Off	On	Off	High	X
Park/Neutral	On	On	Off	Off	On	X	High

